

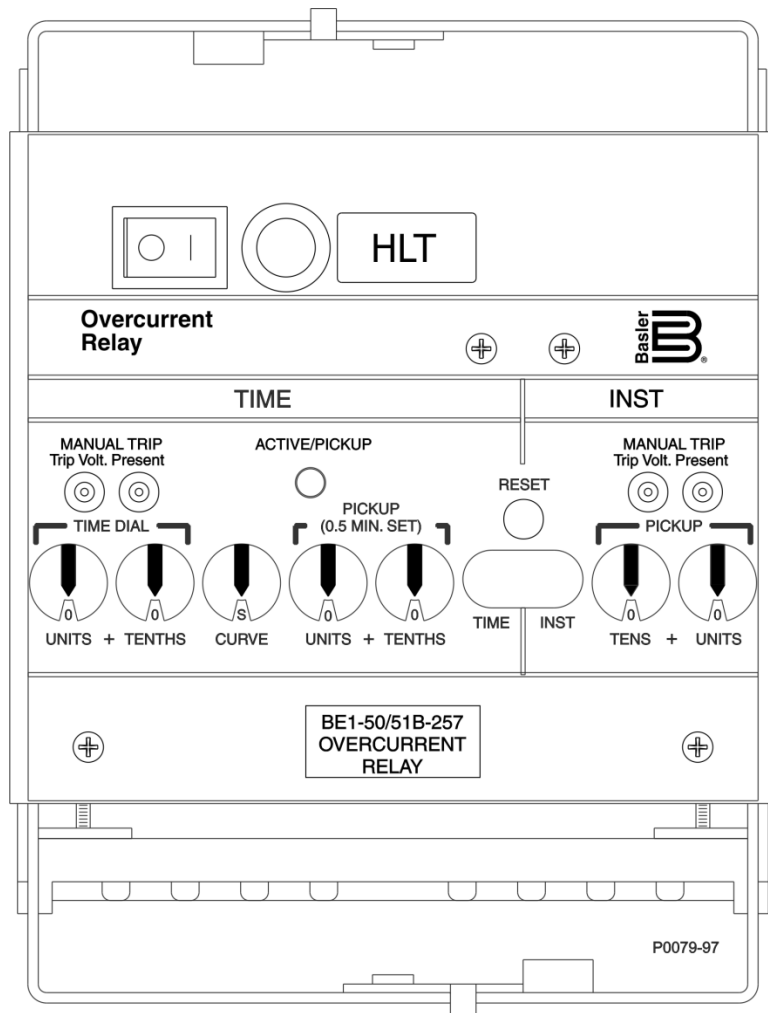



BE1-50/51B-257

Overcurrent Relay

Instruction Manual



 **WARNING:** California's Proposition 65 requires special warnings for products that may contain chemicals known to the state of California to cause cancer, birth defects or other reproductive harm. Please note that by posting this Proposition 65 warning, we are notifying you that one or more of the Proposition 65 listed chemicals may be present in products we sell to you. For more information about the specific chemicals found in this product, please visit <https://www.basler.com/Prop65>.

Preface

This instruction manual provides information about the installation and operation of the BE1-50/51B-257. To accomplish this, the following information is provided:

- General information and specifications
- Controls and indicators
- Functional description
- Installation and maintenance
- Testing

Conventions Used in this Manual

Important safety and procedural information is emphasized and presented in this manual through warning, caution, and note boxes. Each type is illustrated and defined as follows.

Warning!

Warning boxes call attention to conditions or actions that may cause personal injury or death.

Caution

Caution boxes call attention to operating conditions that may lead to equipment or property damage.

Note

Note boxes emphasize important information pertaining to installation or operation.



12570 State Route 143
Highland IL 62249-1074 USA

www.basler.com
info@basler.com

Tel: +1 618.654.2341
Fax: +1 618.654.2351

© 2025 by Basler Electric
All rights reserved
First printing: March 2016

Warning!

READ THIS MANUAL. Read this manual before installing, operating, or maintaining this equipment. Note all warnings, cautions, and notes in this manual as well as on the product. Keep this manual with the product for reference. Only qualified personnel should install, operate, or service this system. Failure to follow warning and cautionary labels may result in personal injury or property damage. Exercise caution at all times.

Basler Electric does not assume any responsibility to compliance or noncompliance with national code, local code, or any other applicable code. This manual serves as reference material that must be well understood prior to installation, operation, or maintenance.

For terms of service relating to this product and software, see the *Commercial Terms of Products and Services* document available at <https://www.basler.com/customer-terms-and-conditions>.

This publication contains confidential information of Basler Electric Company, an Illinois corporation. It is loaned for confidential use, subject to return on request, and with the mutual understanding that it will not be used in any manner detrimental to the interests of Basler Electric Company and used strictly for the purpose intended.

It is not the intention of this manual to cover all details and variations in equipment, nor does this manual provide data for every possible contingency regarding installation or operation. The availability and design of all features and options are subject to modification without notice. Over time, improvements and revisions may be made to this publication. Before performing any of the following procedures, contact Basler Electric for the latest revision of this manual.

The English-language version of this manual serves as the only approved manual version.

Revision History

A historical summary of the changes made to this instruction manual is provided below. Revisions are listed in reverse chronological order.

Instruction Manual Revision History

Manual Revision and Date	Change
F, May 2026	<ul style="list-style-type: none"> • Minor text edits
E, May 2025	<ul style="list-style-type: none"> • Updated China RoHS table • Added FCC statement
D, Nov 2024	<ul style="list-style-type: none"> • Updated manual to reflect changes to main board • Updated burden data
C, Mar 2024	<ul style="list-style-type: none"> • Added China RoHS compliance • Updated relay front drawing
B, Dec 2019	<ul style="list-style-type: none"> • Changed Instantaneous Element 50-A range to 1-99 Aac and added Note box about minimum current required to energize both instantaneous elements in the General Information chapter • Replaced Prop 65 warning on back of Cover page with generic version • Minor text edits throughout manual
A1, Apr 2019	<ul style="list-style-type: none"> • Added Prop 65 warning
A, May 2016	<ul style="list-style-type: none"> • Minor text edits
—, Mar 2016	<ul style="list-style-type: none"> • Initial release



Contents

Introduction	1-1
Controls and Indicators	2-1
Functional Description.....	3-1
Installation.....	4-1
Testing.....	5-1
Specifications.....	6-1
Time Characteristic Curves	7-1



1 • Introduction

BE1-50/51B-257 overcurrent relays are microprocessor-based, non-directional phase or ground relays that monitor the magnitude of a single-phase ac current to provide accurate instantaneous and time overcurrent protection for 50- or 60-Hz power systems.

BE1-50/51B-257 protective relays have three protection elements: one time overcurrent (51) element and two instantaneous overcurrent (50-A and 50-B) elements. The 50-B element provides the Hot Line Tag (HLT) feature. The BE1-50/51B-257 has a 5-ampere current sensing input and is supplied with a case and cover.

Features

A wide range of pickup settings and front panel selectable time characteristics permit applications involving coordination with fuses, reclosers, cold load pickup, motor starting, and fixed time requirements. Also, an integrating reset function is available to simulate the disk reset of electromechanical relays.

BE1-50/51B-257 overcurrent relays have the following standard features.

- Independent time and instantaneous elements
- Hot Line Tag (HLT)
- A secure method to manually trip the breaker at the relay front panel
- Direct reading front panel controls
- Minimum pickup setting for safety during installation
- Time characteristics extend to a pickup multiple of 40
- Rugged draw-out construction
- Gravity-latching targets retain indication without power
- Built-in accuracy eliminates internal adjustments
- Minimum transient overreach
- Field-selectable characteristic curve selection similar to either GE-IAC- or ABB-type curves
- Field-selectable instantaneous or integrating reset
- Field-selectable 50- or 60-Hz operation
- Field-selectable 0.0 or 0.1 second fixed instantaneous delay

Internal Switches

Internal switches provide for selecting system operating frequencies of 50 or 60 Hz, instantaneous element delays of 0.0 or 0.1 second, characteristic curve group selection for either GE-IAC- or ABB-type curves, and instantaneous or integrating reset characteristics. Switch location and description is provided in the *Controls and Indicators* chapter.

Hot Line Tag

The BE1-50/51B-257 relay's instantaneous (50-B) element is used to provide the HLT feature and is invoked when the front-panel HLT switch is closed. The HLT switch places the 50-B trip contact in parallel with the 50-A and 51 trip contacts. Proper setting of the instantaneous (50-B) pickup current level in conjunction with the HLT enable switch provides for quickest possible fault detection. A front-panel indicator is illuminated when HLT is active and trip voltage is present. The BE1-50/51B-257 is suitable only for tripping circuits of 125 V nominal.

Advantages

BE1-50/51B-257 overcurrent relays have many advantages over other overcurrent relays. The primary advantages are:

- Time characteristics are defined by equations and graphs
- Field-selectable time characteristics
- Very low burden extends the linear range of the CTs

- Self-powered from the sensed current
- Continuous automatic calibration

BE1-50/51B-257 overcurrent relays may be tested without removing the relay from the case. Shorting contacts are provided for all current inputs when the connection plugs or relay chassis is removed from the relay case.

2 • Controls and Indicators

Figure 2-1 illustrates the front panel controls and indicators of the BE1-50/51B-257. Figure 2-2 illustrates the circuit board controls. Both illustrations have lettered call-outs that correspond to the control and indicator descriptions provided in Table 2-1.

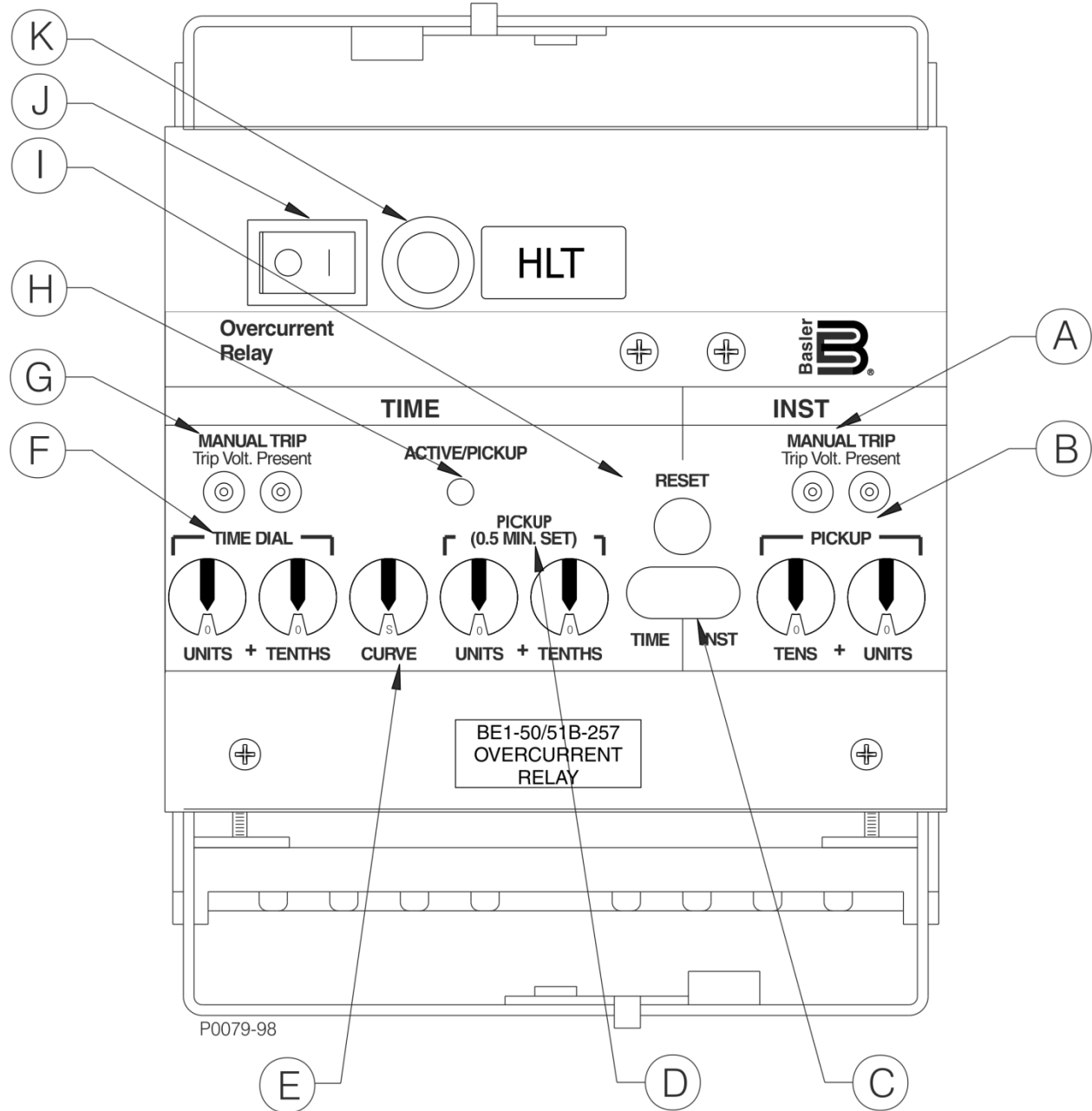

Figure 2-1. Location of Controls and Indicators

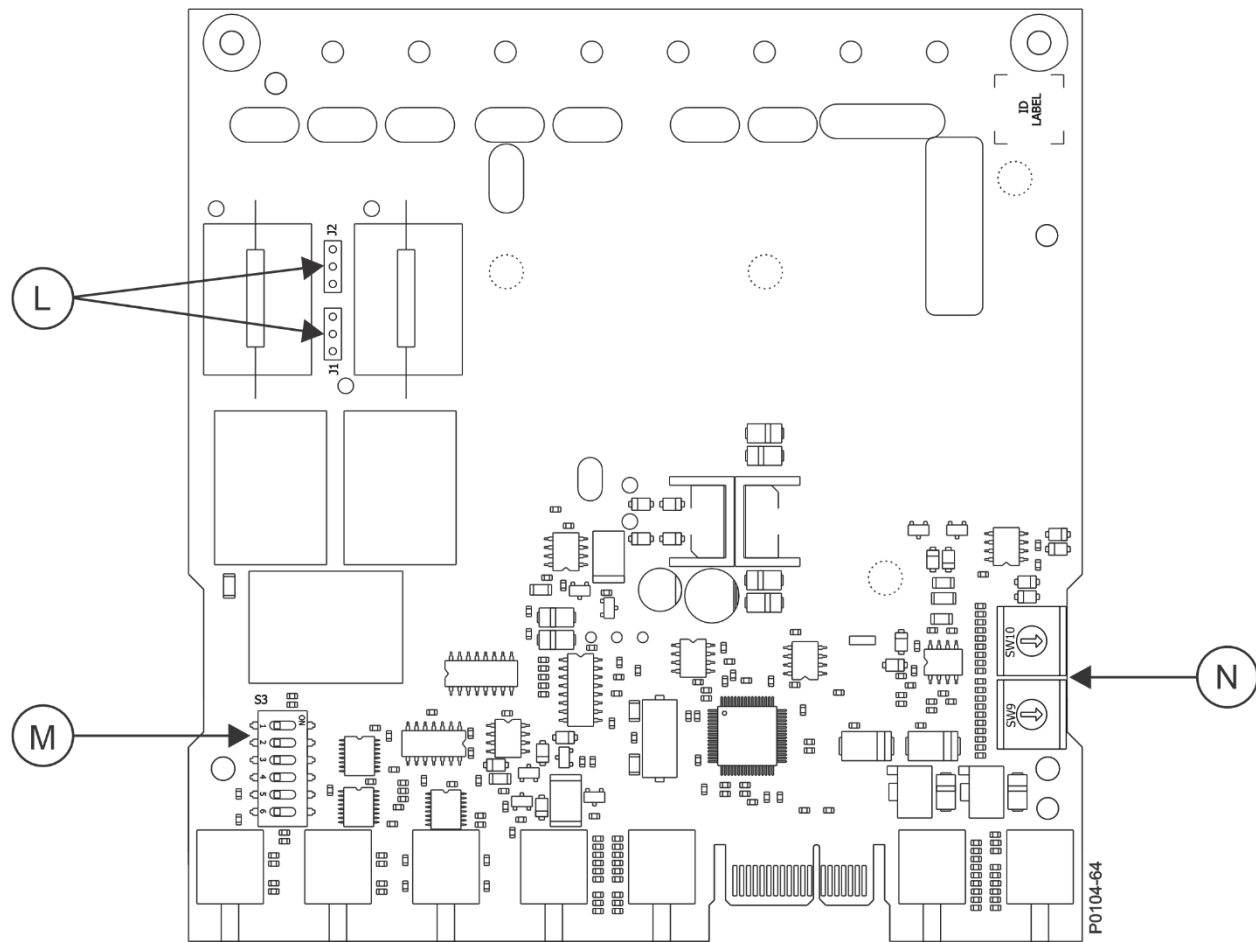

Figure 2-2. Circuit Board Controls

Table 2-1. Controls and Indicators (Refer to Figures 3 and 4)

Locator	Control or Indicator	Function
A	INST MANUAL TRIP Test Points	These jacks are used to manually trip a breaker controlled by the 50-A trip output contacts. This is achieved by plugging a jumper wire, terminated with two standard 0.08-inch diameter phone-tip plugs, into the two jacks. These jacks do not activate the 50-B trip output contacts.
B	INST PICKUP Selectors	These two rotary switches select the instantaneous overcurrent A (50-A) pickup current setting in amperes (TENS and UNITS). Adjusting these selector switches while the relay is in service may cause the relay to trip. Note: When testing time overcurrent functions, instantaneous pickup settings of 00 will affect the calibration of the time functions. Time pickup settings of 00 also affect instantaneous functions.

Locator	Control or Indicator	Function
C	Targets	Red target indicators latch when the corresponding set of trip contacts closes and sufficient trip circuit current is detected. (The level of current that will trip each target indicator is jumper-selectable. See function of Locator L for more information.) The Time target indicates the flow of current in the time overcurrent (51) trip circuit. The Inst target indicates the flow of current in the instantaneous overcurrent A (50-A) trip circuit. No target is provided for the instantaneous overcurrent B (50-B) trip circuit. Both target indicators are reset by pressing the target reset button (locator I).
D	TIME PICKUP Selectors	These two rotary switches select the time overcurrent pickup current setting in amperes (UNITS and TENTHS). Adjusting these selector switches while the relay is in service may cause the relay to trip.
E	CURVE Selector	This ten-position rotary switch selects one of nine inverse timing characteristics or one fixed time function. Refer to the <i>Time Characteristic Curves</i> chapter for details about the timing characteristics of the BE1-50/51B-257.
F	TIME DIAL Selectors	These two rotary switches select the desired curve of the timing characteristic selected by the Curve Selector Switch (locator E). When a fixed time characteristic is used (Curve Selector Switch setting of F), the setting of these switches corresponds to a time delay of 0.0 to 9.9 seconds.
G	TIME MANUAL TRIP Test Points	These jacks are used to manually trip a breaker controlled by the 51 trip output contacts. This is achieved by plugging a jumper wire, terminated with two standard 0.08-inch diameter phone-tip plugs, into the two jacks.
H	ACTIVE/PICKUP LED	This bicolor LED indicates the level of current sensed by the relay. A green LED indicates that the relay is active but not picked up. The LED changes to red when the sensed current exceeds the time overcurrent pickup setting and back to green when the sensed current decreases below 95% of the time overcurrent pickup setting. Note: A minimum of 0.5 A is required to light the LED. The LED may not turn green (active) before turning red (picked up) at the 0.5 A pickup setting.
I	Target RESET Button	Linkage extends through back of front cover to reset both gravity-latched target indicators.
J	Hot Line Tag Switch	This switch enables or disables the Hot Line Tag (HLT) feature. When on (closed), the HLT switch places the 50-B trip contact in parallel with the 50-A and 51 trip contacts.
K	HLT Indicator	This red neon indicator illuminates when the Hot Line Tag (HLT) switch is on (closed) and trip circuit voltage is present.

Locator	Control or Indicator	Function
L	Target Operating Current Jumpers	<p>Two user-adjustable jumpers control the range of trip circuit current required to operate the time overcurrent (51) and instantaneous overcurrent A (50-A) target indicators. Jumper J1 sets the minimum current range for the 50-A target indicator and J2 sets the minimum current range for the 51 target indicator.</p> <p>Two jumper positions are possible: across pins 1 and 2 or across pins 2 and 3. Installing a jumper across pins 1 and 2 gives a minimum operating current of 0.9 to 2.25 A. Installing a jumper across pins 2 and 3 gives a minimum operating current of 80 to 200 mA.</p>
M	Six-Position Slide Switch	<p>This switch assembly is designated SW3. Each switch functions as follows:</p> <p>SW3-1 selects the nominal system frequency. The OFF position selects 60-Hz operation and the ON position selects 50-Hz operation.</p> <p>SW3-2 provides an additional time delay for the instantaneous overcurrent A (50-A) element. The ON position provides an additional delay of 100 milliseconds.</p> <p>SW3-3 selects either GE-IAC- or ABB-type characteristic curves. The ON position selects the GE-IAC-type curves (see the <i>Time Characteristic Curves</i> chapter) and the OFF position selects the ABB-type curves (see the <i>Time Characteristic Curves</i> chapter).</p> <p>SW3-4 selects either an instantaneous or integrating time reset characteristic. The ON position selects an integrating reset characteristic and the OFF position selects an instantaneous reset characteristic.</p> <p>SW3-5 is not used.</p> <p>SW3-6 is not used.</p>
N	Instantaneous Overcurrent B Pickup Selector Switches	<p>These two screwdriver-adjusted rotary switches select the instantaneous overcurrent B (50-B) pickup current setting in amperes.</p> <p>The 50-B pickup switches are accessed on the top side of the draw-out assembly by removing the draw-out assembly from the case.</p> <p>The left-hand switch (SW9) is a 16-position switch that sets the units portion (<u>#.#</u>) of the 50-B pickup setting in amperes. SW9 setting positions consist of 0 through 9 which correspond to values of 0 to 9 amperes and A through F which correspond to values of 10 to 15 amperes.</p> <p>The right-hand switch (SW10) is a 10-position switch that sets the tenths portion (<u>#.#</u>) of the 50-B pickup setting in amperes. SW10 setting positions consist of 0 through 9 which correspond to values of 0.0 to 0.9 amperes.</p> <p>The minimum allowable 50-B pickup setting is 1.0 Aac and the maximum allowable 50-B pickup setting is 15.9 Aac. Adjusting the 50-B pickup selector switches while the relay is in service may cause the relay to trip.</p> <p>Example: SW9 position 2 and SW10 position 5 is a setting of 2.5 Aac.</p>

3 • Functional Description

BE1-50/51B-257 Overcurrent Relays are microprocessor-based, non-directional relays that measure ac current to provide secure and reliable instantaneous and time overcurrent protection for power systems.

Figure 3-1 illustrates the functional block diagram.

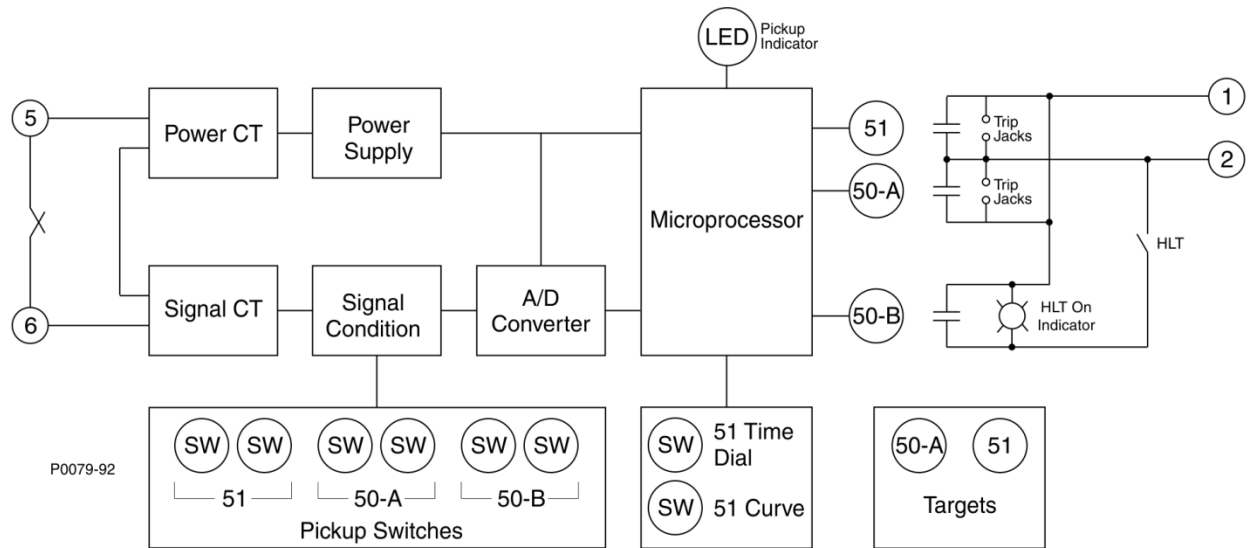

Figure 3-1. Functional Block Diagram

Current Sensing Input

Single-phase ac current supplied by a system current transformer (CT) is applied to the BE1-50/51B-257 through terminals 5 and 6. Sensing current is applied to internal power and signal CTs.

Power CT and Power Supply

The output of the power CT is supplied to the power supply which provides rectified and filtered operating power for all relay circuitry. A precision 5 Vdc output of the power supply serves as a reference for automatic calibration.

Signal Conditioning

Current from the signal CT is rectified and applied to three independent sets of scaling resistors controlled by the Time Overcurrent (51), Instantaneous Overcurrent A (50-A), and Instantaneous Overcurrent B (50-B) pickup switches. The analog-to-digital converter receives the analog voltage developed across the scaling resistors and converts it into a digital signal that is supplied to the microprocessor.

Microprocessor

The microprocessor performs program operations based on the sensed current, switch settings, and the internal software program.

When sufficient current is sensed by the relay, the microprocessor is active and executing code, and the Active/Pickup LED is green. When the sensed current decreases below the operating threshold, microprocessor operation is interrupted and the Active/Pickup LED turns off. A watchdog circuit resets the microprocessor program when code execution is interrupted.

Power-off sensing circuits measure the voltage across a capacitor at power-down and power-up. These circuits determine how long power has been removed based on the difference voltage and the circuit's RC time constant. This provides information from the integrating reset function even when power has been entirely removed.

The microprocessor performs the program operations based on the inputs and the internal software program. When the sensed current exceeds the TIME PICKUP setting, the ACTIVE/PICKUP LED turns from green to red. The 50-A/51 contact is closed in accordance with the TIME characteristic equation or if the sensed current exceeds the INST PICKUP setting. Likewise, sensed current exceeding the Instantaneous Overcurrent B Pickup selector switch setting causes the 50-B Trip output contacts to close.

Outputs

The Time Overcurrent (51) and Instantaneous Overcurrent A (50-A) protective elements are equipped with a set of normally-open contacts rated for tripping duty. A system circuit breaker controlled by the 51 or 50-A output contacts can be manually tripped by connecting a jumper across the Time Overcurrent Manual Trip jacks or the Instantaneous Overcurrent Manual Trip jacks. Current flow in a trip circuit is indicated by operation of the corresponding target. The targets will not operate without adequate relay operating power.

Warning!

Trip circuit voltage is present at the front panel test points. When shorting the test points, use insulated jumpers to avoid contact with these voltages.

Target Indicators

Gravity-latched, manually-reset, current-operated target indicators are provided for the time overcurrent (51) trip output and the instantaneous overcurrent A (50-A) trip output. A target indicator is not provided for the 50-B trip output. The level of trip circuit current required to operate each target is individually controlled by a circuit board jumper. The minimum operating current range can be set for 80 to 200 milliamperes or 0.9 to 2.25 amperes. See the *Controls and Indicators* chapter for jumper locations and function assignments.

Hot Line Tag (HLT)

Closure of the front-panel HLT switch places the 50-B trip contact in parallel with the 50-A and 51 trip contacts. A front-panel indicator signals when HLT is active. The BE1-50/51B-257 is suitable only for 125 V nominal tripping circuits.

4 • Installation

When not shipped as part of a control or switchgear panel, the relays are shipped in sturdy cartons to prevent damage during transit. Immediately upon receipt of a relay, check the model and part number against the requisition and packing list to see that they agree. Visually inspect the relay for damage that may have occurred during shipment. If there is evidence of damage, immediately file a claim with the carrier and notify the Regional Sales Office, or contact the Sales Representative at Basler Electric, Highland, Illinois.

Proper operation of the relay may be confirmed by performing the operational test procedure in the *Testing* chapter. If the relay will not be installed immediately, store the relay in its original shipping carton in a moisture- and dust-free environment.

Factory Settings

Factory settings for the internal switches of SW3 and jumper settings are as follows:

- SW3-1 — OFF (60-hertz operation)
- SW3-2 — OFF (0.0 additional fixed delay for the instantaneous element)
- SW3-3 — ON (GE-IAC-type characteristic curves)
- SW3-4 — ON (Integrating reset characteristics)
- SW3-5 — Not used
- SW3-6 — Not used
- J1 pins 2-3 — 50-A minimum target operating current of 80 to 200 mA
- J2 pins 2-3 — 51 minimum target operating current of 80 to 200 mA

Mounting

Relay outline dimensions and panel drilling diagrams are shown in Figures 4-1 through 4-4. Dimensions in parentheses are in millimeters.

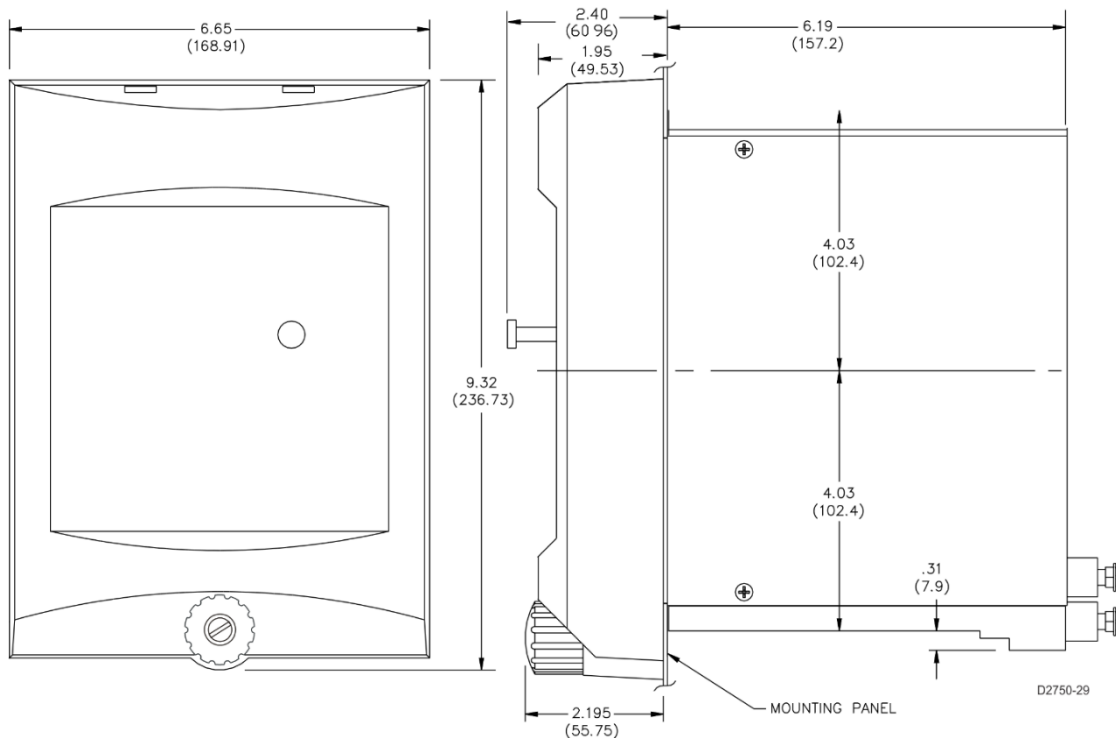

Figure 4-1. Outline Dimensions for S1 Case, Semi-Flush Mounting

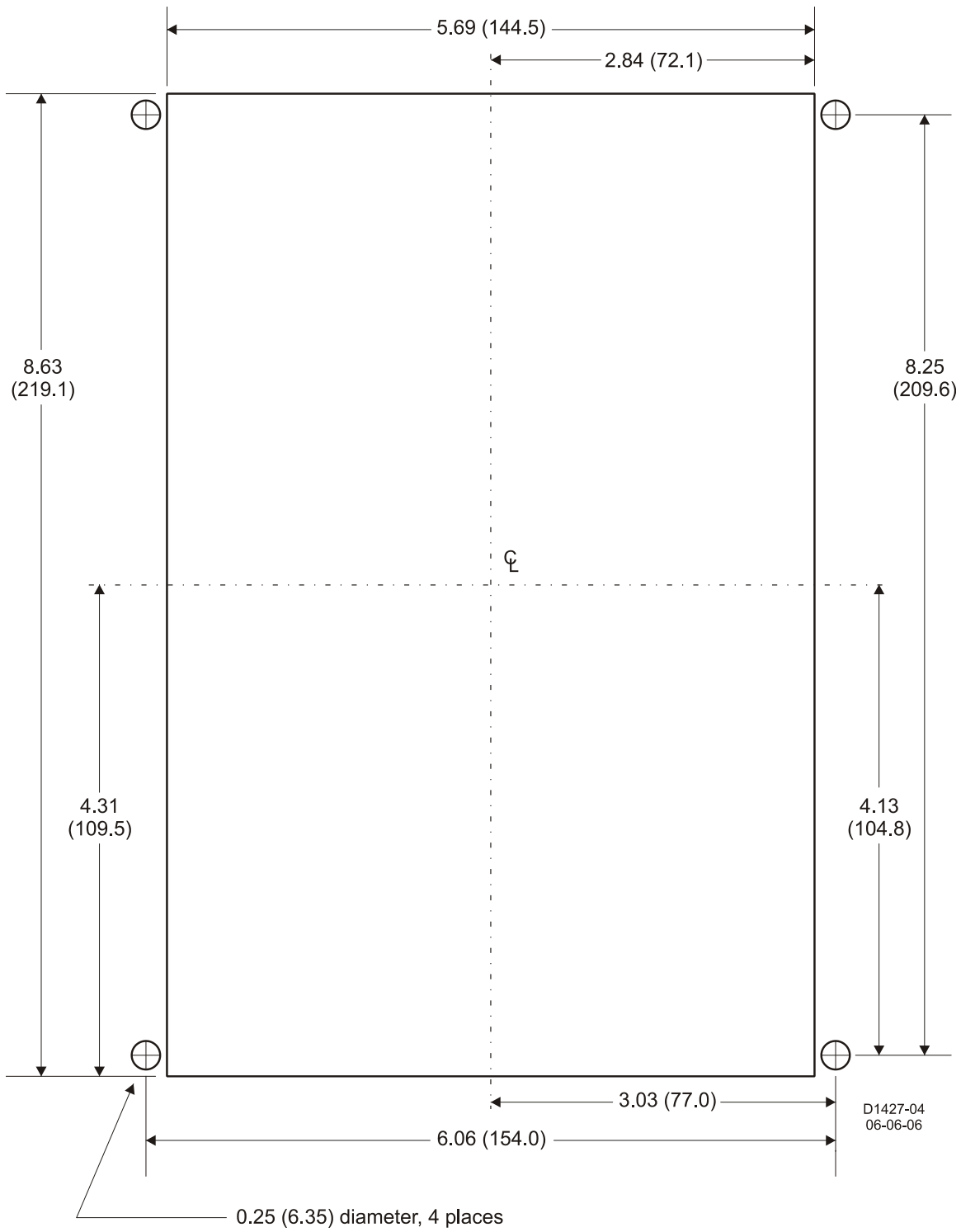

Figure 4-2. Panel Drilling Diagram for S1 Case, Semi-Flush Mounting

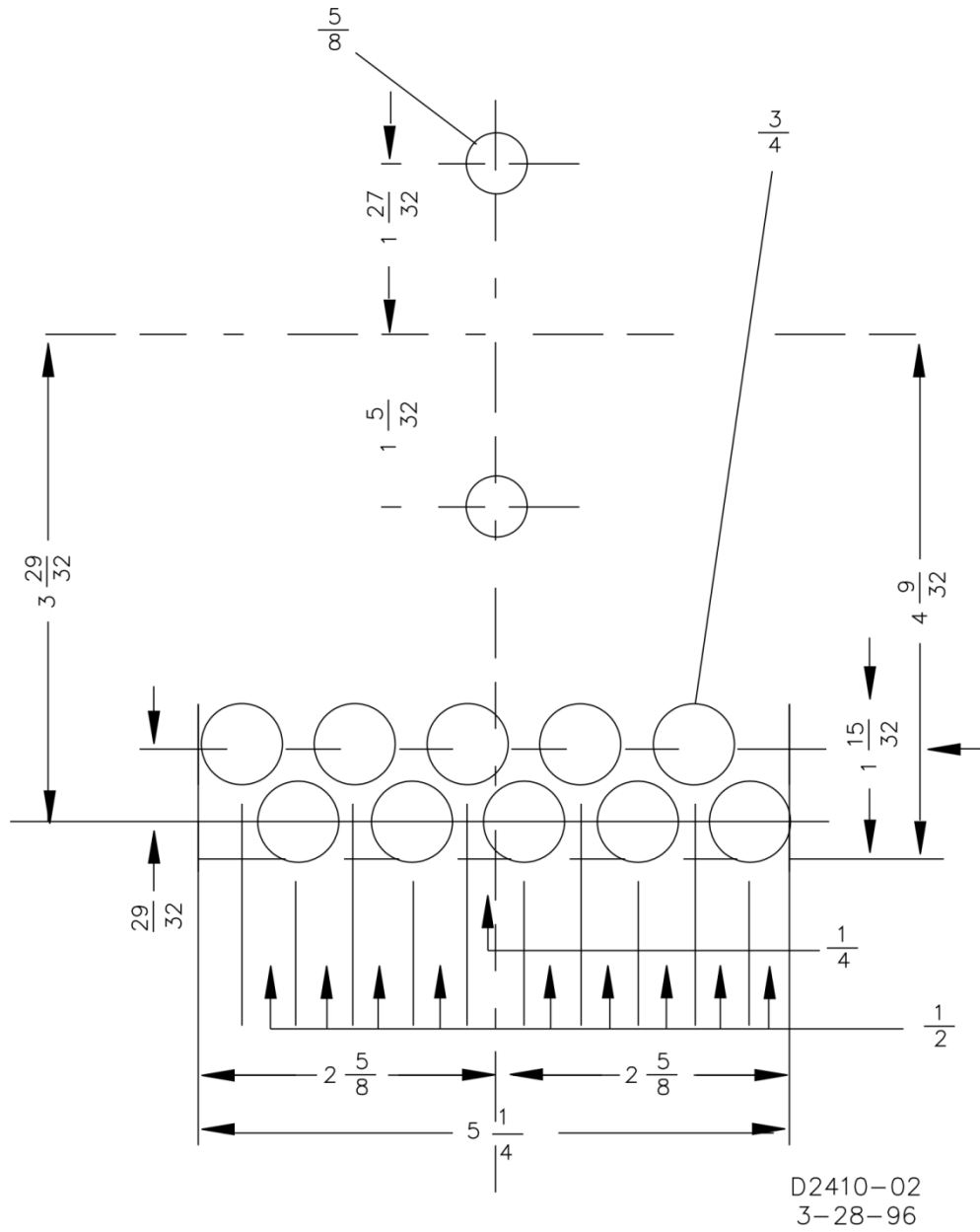

Figure 4-3. Panel Drilling Diagram for S1 Case, Projection Mounting

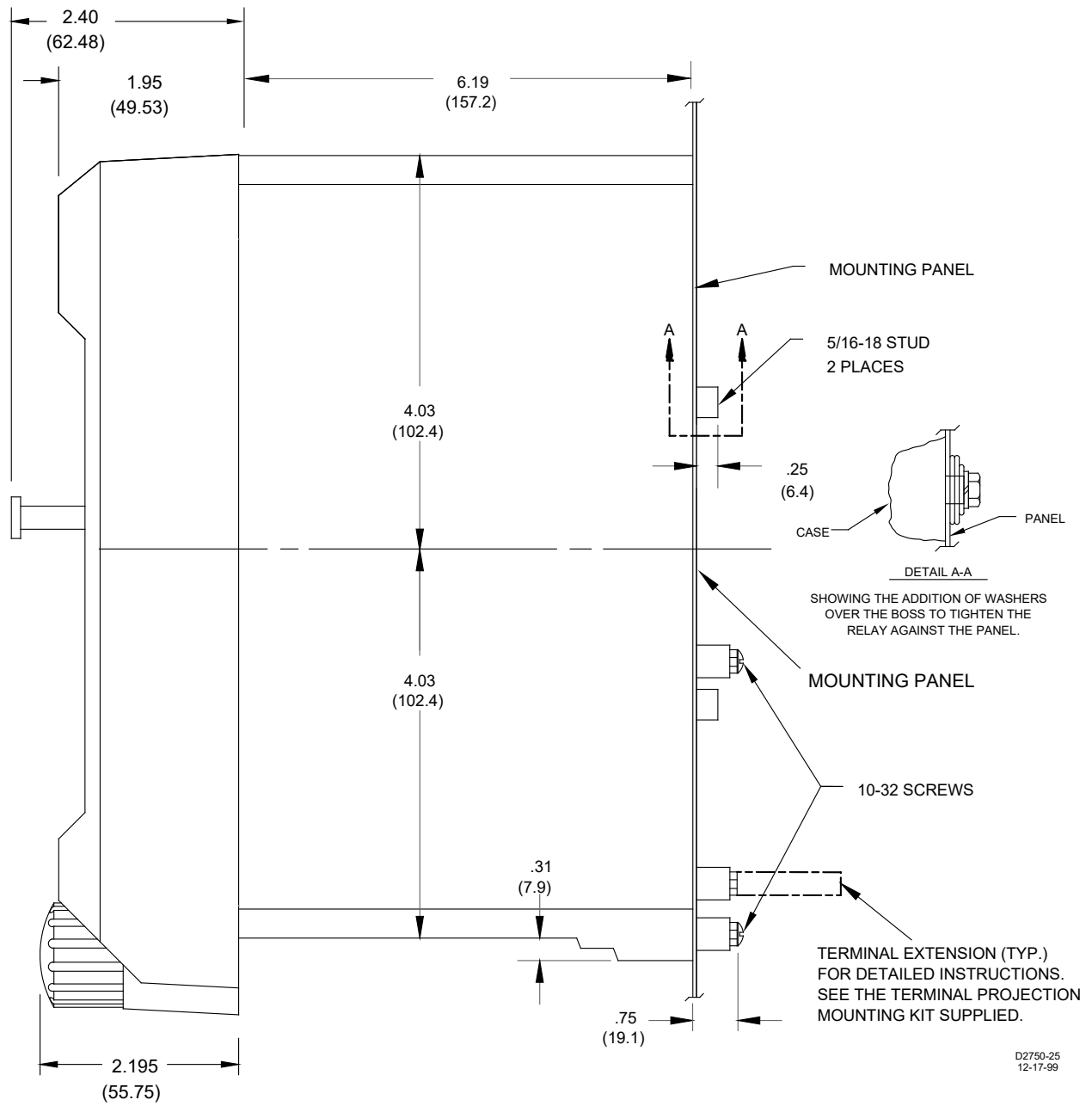

Figure 4-4. Outline Dimensions for S1 Case, Projection Mounting

Connections

Typical ac input connections for the BE1-50/51B-257 are shown in Figure 4-5. Typical dc control connections for the BE1-50/51B-257 are shown in Figure 4-6. Refer to the block diagrams in the *Functional Description* chapter for relay internal connections.

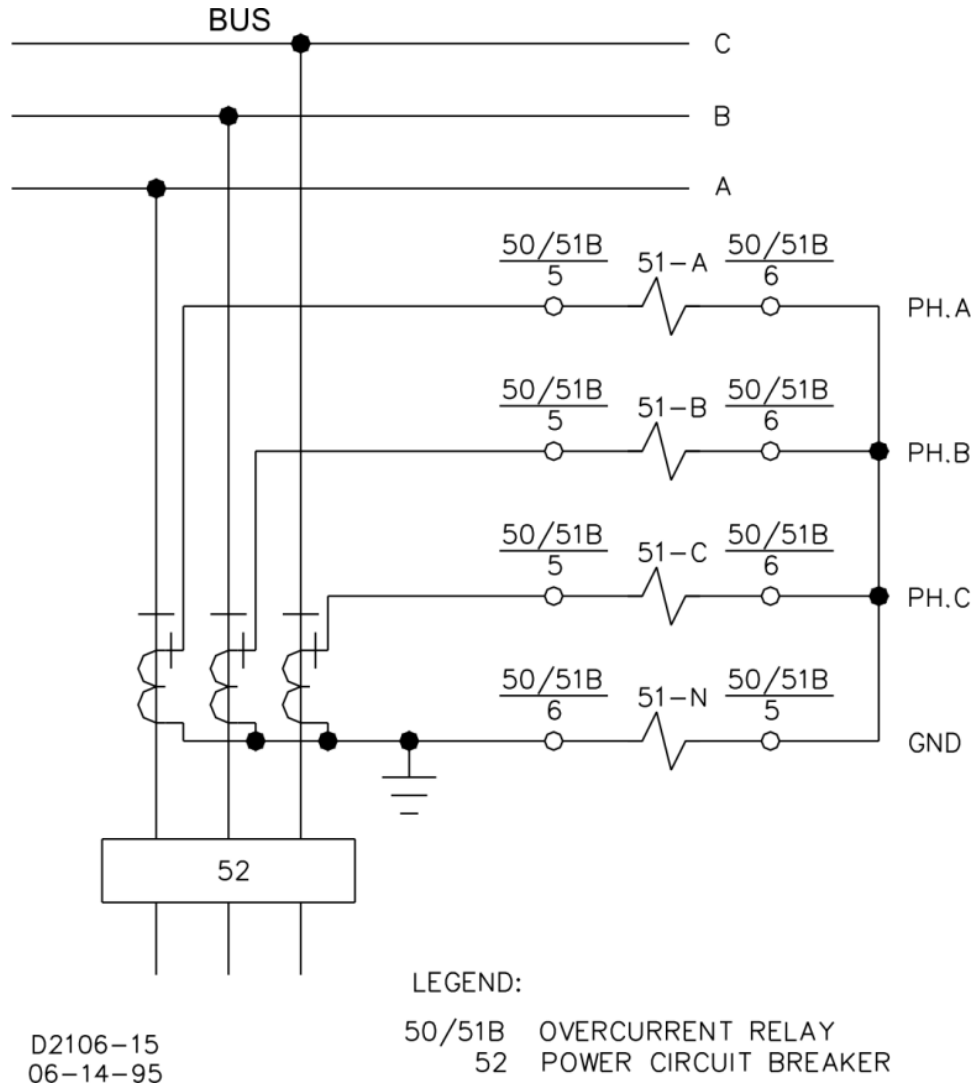

Figure 4-5. AC Input Connections

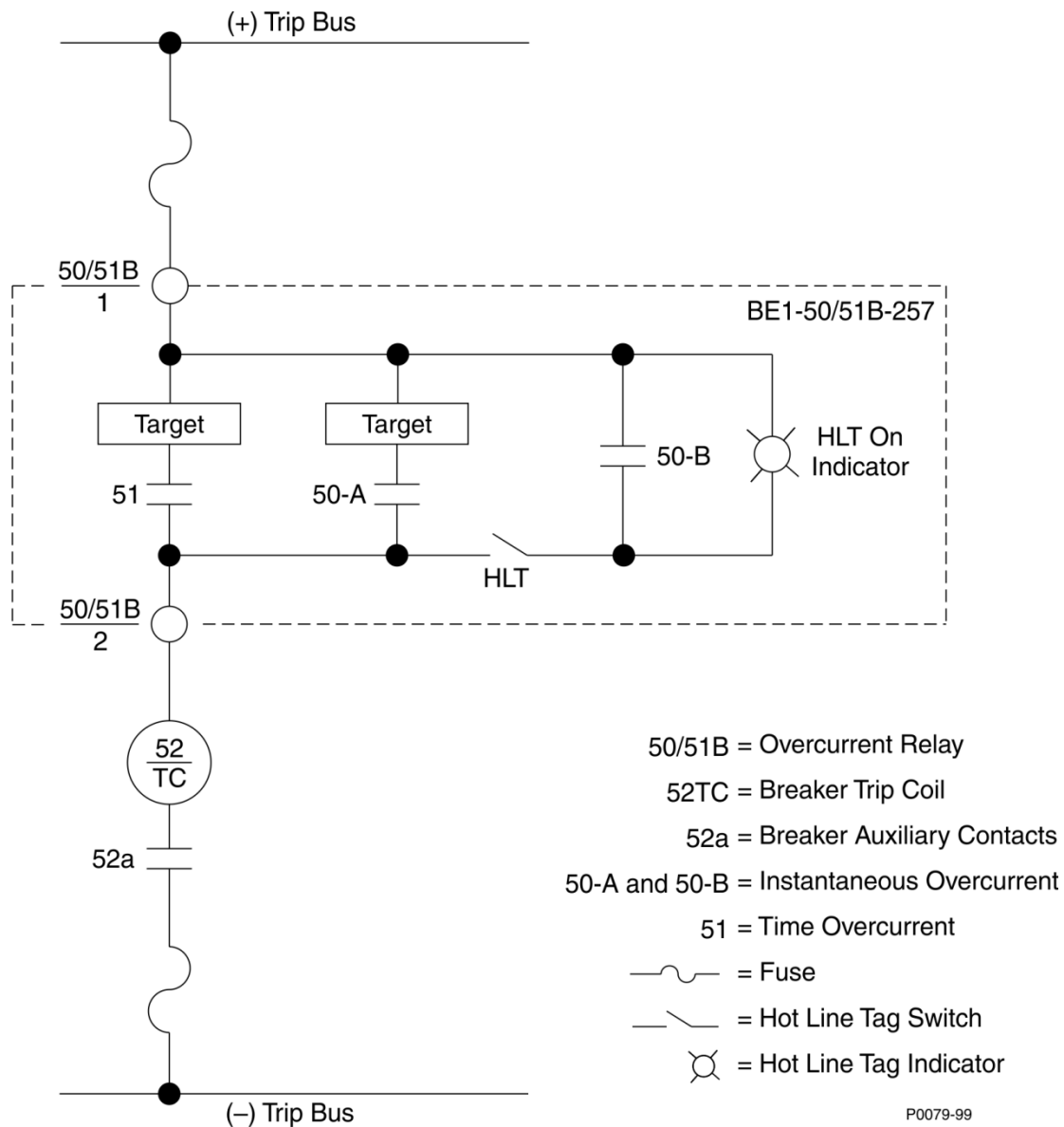

Figure 4-6. DC Control Connections

Application Coordination

In a typical application coordination scheme, a BE1-50/51B-257 is being used to provide primary protection for a radial distribution feeder. An electromechanical overcurrent relay with extremely inverse timing provides protection for the transformer and bus. To improve coordination with the electromechanical relay, the BE1-50/51B-257 is configured with the following settings:

- Integrating reset enabled (SW3-4 ON)
- GE-IAC-type curves selected (SW3-3 ON)

The feeder reclosing relay is set for two reclose attempts at 3 and 15 seconds after the initial trip. If a permanent fault occurs (magnitude ten times pickup), calculate the feeder breaker trip time for each of the three operations. Refer to the *Time Characteristic Curves* chapter for characteristic curve constants.

From the time characteristic curve equation:

$$\begin{aligned}
 T_{\text{Trip}} &= \frac{AD}{M^N - C} + BD + K \\
 &= \frac{7.7624 \times 2}{10^{2.0938} - 1} + (0.02758 \times 2) + 0.028 \\
 &= \frac{15.5248}{124.10806 - 1} + 0.05516 + 0.028 \\
 &= 0.209 \text{ seconds}
 \end{aligned}$$

From the reset characteristic curve equation:

$$\begin{aligned}
 T_{\text{Reset}} &= \frac{RD}{M^2 - 1} \\
 &= \frac{7.75 \times 2}{0^2 - 1} = -15.5 \text{ seconds}
 \end{aligned}$$

$M = 0$ if current goes to zero.

Negative result indicates reset time.

Results: Full trip = 0.209 seconds and full reset = 15.5 seconds if current goes to zero.

In Figure 4-7,

$T_A = 0.209$ seconds (relay was at reset).

$T_B = \text{value} < T_A$ because rewind has not gone to zero.

$T_C = \text{value} < T_A$ because rewind has not gone to zero.

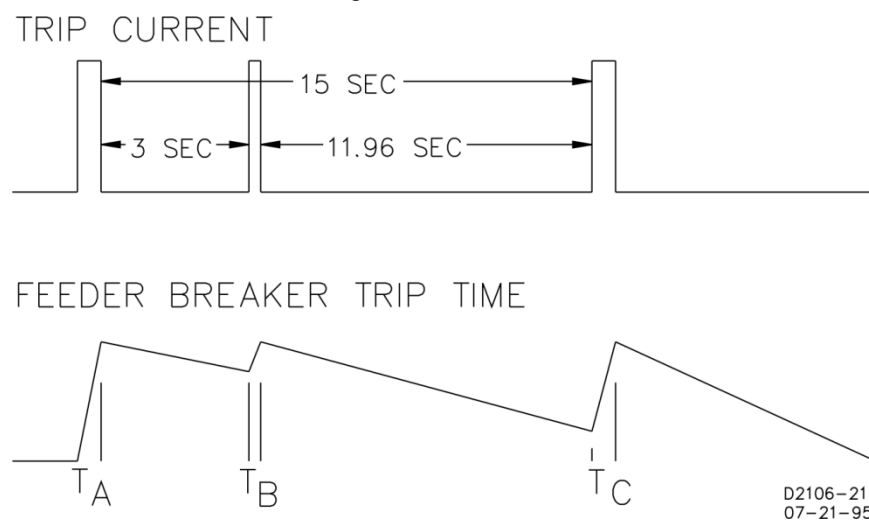

Figure 4-7. Coordination Timing Diagram

Equation for time to trip during rewind (before relay is reset).

$$T_{\text{Trip This Occurrence}} = \frac{(\text{Full Trip})(\text{Rewind Time})}{\text{Full Rewind}}$$

Second Operation

$$T_B = \frac{(0.209)(3)}{15.5}$$

$$T_B = 0.040 \text{ seconds}$$

Third Operation

$$T_C = \frac{(0.209)(11.96)}{15.5}$$

$$T_C = 0.161 \text{ seconds}$$

Maintenance

BE1-50/51B-257 overcurrent relays require no preventive maintenance. However, periodic checks should be performed according to scheduled practices. A recommended periodic test is provided in the *Testing* chapter. If the relay fails to function properly, contact the Technical Sales Support Department of Basler Electric.

Storage

This device contains long-life aluminum electrolytic capacitors. For devices that are not in service (spares in storage), the life of these capacitors can be maximized by energizing the device for 30 minutes once per year.

5 • Testing

Dielectric testing, operational testing, and periodic testing are described in the following paragraphs.

Dielectric Test

In accordance with IEC 255-5 and IEEE C37.90-2005, one-minute dielectric (high potential) tests may be performed as follows:

- All circuits to cradle2,828 Vdc or 2,000 Vac
- Input to output circuits2,828 Vdc or 2,000 Vac

Output contacts are surge protected.

Operational Test Procedure

The following procedures verify operation of the BE1-50/51B-257 relay. The test setups of Figures 5-1 and 5-2 are intended primarily as an illustration of the principles involved. Other test setups known to be capable of testing with the stated and implied tolerances (including equipment specifically designed for testing relays) may be used.

Caution

To ensure proper timing during testing, before each test, remove the current from the unit for R times D seconds (refer to the *Specifications* chapter for R and D definitions).

Note

When testing TIME overcurrent functions, INST PICKUP settings of 00 will affect the calibration of the TIME functions. TIME PICKUP settings of 00 also affect INST functions.

Test Equipment Required

- Current source with a range from 0 to 20 Aac (sensing input current)
- DC power source (target operation)
- Timer or counter

Test Procedure

Time Overcurrent (51) Pickup

1. Connect and configure the relay for 51 pickup testing:
 - a. Connect the test setup shown in Figure 5-1.
 - b. Set circuit board switch SW3 as follows:
 - SW3-1 = ON for 50-Hz operation or OFF for 60- Hz operation
 - SW3-2 = OFF (no additional time delay for the 50-A element)
 - SW3-3 = ON (GE-IAC-type characteristic curves)
 - SW3-4 = ON (integrating reset characteristic)
 - c. Set the TIME DIAL to 0.0.

- d. Set CURVE to S.
 - e. Set TIME PICKUP to 0.5.
 - f. Set INST PICKUP (50-A) to 90.
 - g. Set INST PICKUP (50-B) (accessed at the top side of the assembly) to F0 (15.0 Aac).
 - h. Open the Hot Line Tag (HLT) switch.
2. Apply and increase current to terminals 5 and 6 until the Active/Pickup LED turns red. The applied current should be no greater than 0.55 Aac.
 3. Decrease the applied current until the Active/Pickup LED changes from red to green and then off.
 4. Set TIME PICKUP to 2.2.
 5. Slowly increase current to terminals 5 and 6 until the Active/Pickup LED turns red. The applied current should be between 2.131 and 2.269 Aac.
 6. Reduce the applied current to zero.

Time Dial

1. Connect and configure the relay for time dial testing:
 - a. Connect the test setup shown in Figure 5-1.
 - b. Set circuit board switch SW3 as follows:
 - SW3-1 = ON for 50-Hz operation or OFF for 60-Hz operation
 - SW3-2 = OFF (no additional time delay for the 50-A element)
 - SW3-3 = ON (GE-IAC-type characteristic curves)
 - SW3-4 = ON (integrating reset characteristic)
 - c. Set TIME DIAL to 4.5.
 - d. Set CURVE to S.
 - e. Set TIME PICKUP to 1.0.
 - f. Set INST PICKUP (50-A) to 90.
 - g. Set INST PICKUP (50-B) (accessed at the top side of the assembly) to F0 (15.0 Aac).
 - h. Open the Hot Line Tag (HLT) switch.
2. Prepare to apply 1.5 Aac to terminals 5 and 6 and record the elapsed time from when current is applied until the 51 output contacts close.
3. Apply the current (step from 0 to 1.5 Aac) and record the elapsed time. The elapsed time should be between 0.345 and 0.424 seconds. (This tolerance is greater than $\pm 2\%$ because it is the accumulation of both pickup and timing tolerances.)
4. Remove the input current.

Integrating Reset

1. Connect and configure the relay for integrating reset testing.
 - a. Connect the test setup shown in Figure 5-1.
 - b. Set circuit board switch SW3 as follows:
 - SW3-1 = ON for 50-Hz operation or OFF for 60-Hz operation
 - SW3-2 = OFF (no additional time delay for the 50-A element)
 - SW3-3 = ON (GE-IAC-type characteristic curves)
 - SW3-4 = ON (integrating reset characteristic)

- c. Set TIME DIAL to 9.9
 - d. Set CURVE to V.
 - e. Set TIME PICKUP to 1.0.
 - f. Set INST PICKUP (50-A) to 90.
 - g. Set INST PICKUP (50-B) (accessed at the top side of the assembly) to F0 (15.0 Aac).
 - h. Open the Hot Line Tag (HLT) switch.
2. Apply 4.0 Aac to terminals 5 and 6. After the unit trips, remove the applied current for 29 ± 0.25 seconds, then reapply the current (4.0 Aac). Note the elapsed time from the reapplication of current to the second trip. The elapsed time should be 2.08 ± 0.4 seconds.

Instantaneous Overcurrent A (50-A) Pickup

1. Connect and configure the relay for 50-A pickup testing:
 - a. Connect the test setup shown in Figure 5-1.
 - b. Set circuit board switch SW3 as follows:
 - SW3-1 = ON for 50-Hz operation or OFF for 60-Hz operation
 - SW3-2 = OFF (no additional time delay for the 50-A element)
 - SW3-3 = ON (GE-IAC-type characteristic curves)
 - SW3-4 = ON (integrating reset characteristic)
 - c. Set TIME DIAL to 0.0.
 - d. Set CURVE to S.
 - e. Set TIME PICKUP to 15.0.
 - f. Set INST PICKUP (50-A) to 02.
 - g. Set INST PICKUP (50-B) (accessed at the top side of the assembly) to F0 (15.0 Aac).
 - h. Open the Hot Line Tag (HLT) switch.
2. Apply and slowly increase current to terminals 5 and 6 until the 50-A output contacts close. The applied current should be between 1.935 and 2.065 Aac.
3. Decrease the applied current until the 50-A output contacts open.
4. Set INST PICKUP (50-A) to 08.
5. Slowly increase the current applied to terminals 5 and 6 until the 50-A output contacts close. The applied current should be between 7.815 and 8.185 Aac.
6. Reduce the applied current to zero.

Instantaneous Overcurrent B (50-B) Pickup

1. Connect and configure the relay for 50-B pickup testing:
 - a. Connect the test setup shown in Figure 5-1.
 - b. Set circuit board switch SW3 as follows:
 - SW3-1 = ON for 50-Hz operation or OFF for 60-Hz operation
 - SW3-2 = OFF (no additional time delay for the 50-A element)
 - SW3-3 = ON (GE-IAC-type characteristic curves)
 - SW3-4 = ON (integrating reset characteristic)
 - c. Set TIME DIAL to 0.0.
 - d. Set CURVE to S.

- e. Set TIME PICKUP to 15.0.
 - f. Set INST PICKUP (50-A) to 90.
 - g. Set INST PICKUP (50-B) (accessed at the top side of the assembly) to 20 (2.0 Aac).
 - h. Close the Hot Line Tag (HLT) switch.
2. Apply and slowly increase current to terminals 5 and 6 until terminals 1 and 10 close. The applied current should be between 1.935 and 2.065 Aac.
 3. Decrease the applied current until terminals 1 and 10 open.
 4. Set INST PICKUP (50-B) to 80 (8.0 Aac).
 5. Slowly increase the current applied to terminals 5 and 6 until terminals 1 and 10 close. The applied current should be between 7.815 and 8.185 Aac.
 6. Reduce the applied current to zero.

Target Indicators

1. Connect and configure the relay for target indicator testing:
 - a. Connect the test setup shown in Figure 5-2.
 - b. Set circuit board switch SW3 as follows:
 - SW3-1 = ON for 50-Hz operation or OFF for 60-Hz operation
 - SW3-2 = OFF (no additional time delay for the 50-A element)
 - SW3-3 = ON (GE-IAC-type characteristic curves)
 - SW3-4 = ON (integrating reset characteristic)
 - c. Set TIME DIAL to 0.0.
 - d. Set CURVE to S.
 - e. Set TIME PICKUP to 1.0.
 - f. Set INST PICKUP (50-A) to 90.
 - g. Set INST PICKUP (50-B) (accessed at the top side of the assembly) to F0 (15.0 Aac).
 - h. Open the Hot Line Tag (HLT) switch.
2. Apply 2 Aac to terminals 5 and 6 to trip the 51 relay output.
3. Slowly increase the power source to provide target current and verify that the Time target operates at the level of current determined by the Target Operating Current Jumpers.

The Target Operating Current Jumpers are located on the circuit board and identified as J1 and J2. J1 sets the minimum current range for the 50-A target and J2 sets the minimum current range for the 51 target. A jumper installed across pins 1 and 2 gives a minimum operating current of 0.9 to 2.25 A. A jumper installed across pins 2 and 3 gives a minimum operating current of 80 to 200 mA.
4. Remove the target and sensing current and reset the target.
5. Set TIME PICKUP to 9.0.
6. Set INST PICKUP (50-A) to 01.
7. Apply 2 Aac to terminals 5 and 6 to trip the 50-A relay output.
8. Slowly increase the power source to provide target current and verify that the Instantaneous target operates at the level of current determined by the Target Operating Current Jumpers.
9. Remove the target and sensing current and reset the target.

Hot Line Tag (HLT) Switch

1. Connect and configure the relay for Hot Line Tag testing:
 - a. Connect the test setup shown in Figure 5-2.
 - b. Set circuit board switch SW3 as follows:
 - SW3-1 = ON for 50-Hz operation or OFF for 60-Hz operation
 - SW3-2 = OFF (no additional time delay for the 50-A element)
 - SW3-3 = ON (GE-IAC-type characteristic curves)
 - SW3-4 = ON (integrating reset characteristic)
 - c. Set TIME DIAL to 0.0.
 - d. Set CURVE to S.
 - e. Set TIME PICKUP to 15.0.
 - f. Set INST PICKUP (50-A) to 90.
 - g. Set INST PICKUP (50-B) (accessed at the top side of the assembly) to 20 (2.0 Aac).
 - h. Open the Hot Line Tag (HLT) switch.
2. Set the power source to provide a target current of 1.0 ampere.
3. Close the HLT switch and verify that the HLT neon light is illuminated.
4. Apply 3 amperes input current to terminals 5 and 6. Check that terminals 1 and 10 close.
5. Remove input current.
6. Open the HLT switch and verify that the HLT neon light is not illuminated.
7. Apply 3 amperes input current to terminals 5 and 6. Check that terminals 1 and 10 do not close.

Manual Trip

1. Configure the relay for manual trip testing:
 - a. Connect the test setup as shown in Figure 5-2.
 - b. Set circuit board switch SW3 as follows:
 - SW3-1 = ON for 50-Hz operation or OFF for 60-Hz operation
 - SW3-2 = OFF (no additional time delay for the 50-A element)
 - SW3-3 = ON (GE-IAC-type characteristic curves)
 - SW3-4 = ON (integrating reset characteristic)
 - c. Set TIME DIAL to 0.0
 - d. Set CURVE to S.
 - e. Set TIME PICKUP to 1.0.
 - f. Set INST PICKUP (50-A) to 90.
 - g. Set INST PICKUP (50-B) (accessed at the top side of the assembly) to 20 (2.0 Aac).
 - h. Open the Hot Line Tag (HLT) switch.

Warning!

Trip circuit voltage is present at the front panel test points. When shorting the test points, use insulated jumpers to avoid contact with these voltages.

2. Apply 0.9 Aac to terminals 5 and 6 (0.9 Aac provides relay operating power but is below the pickup threshold.)
3. Connect a jumper to the Time Overcurrent Manual Trip jacks. Verify that the stop input of the test set recognizes a 51 contact closure.
4. Remove the jumper and the current applied at relay terminals 5 and 6.
5. Apply 0.9 Aac to terminals 5 and 6.
6. Connect a jumper to the Instantaneous Overcurrent Manual Trip jacks. Verify that the stop input of the test set recognizes a 50-A contact closure.
7. Remove the jumper and the current applied to relay terminals 5 and 6.
8. Reset targets.

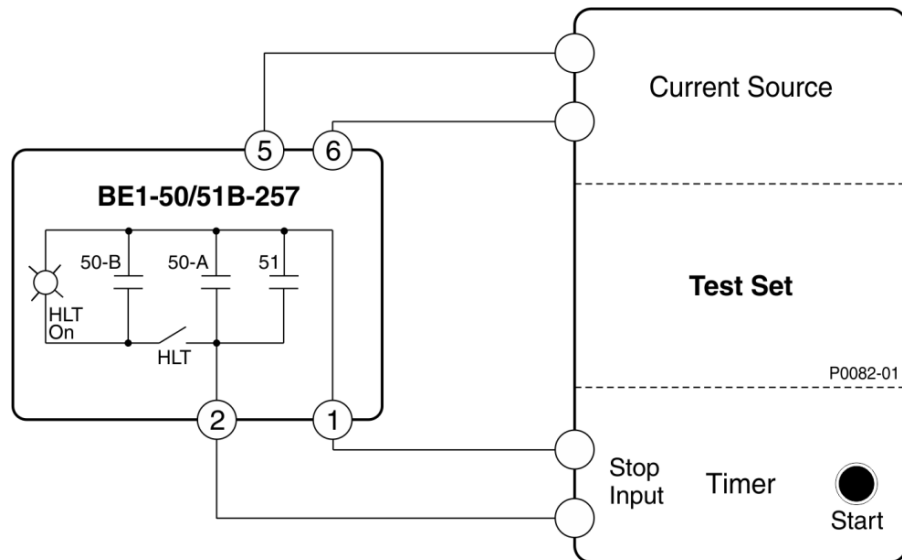

Figure 5-1. 51 Pickup, Time Dial, Integrating Reset, 50-A and 50-B Pickup Test Setup

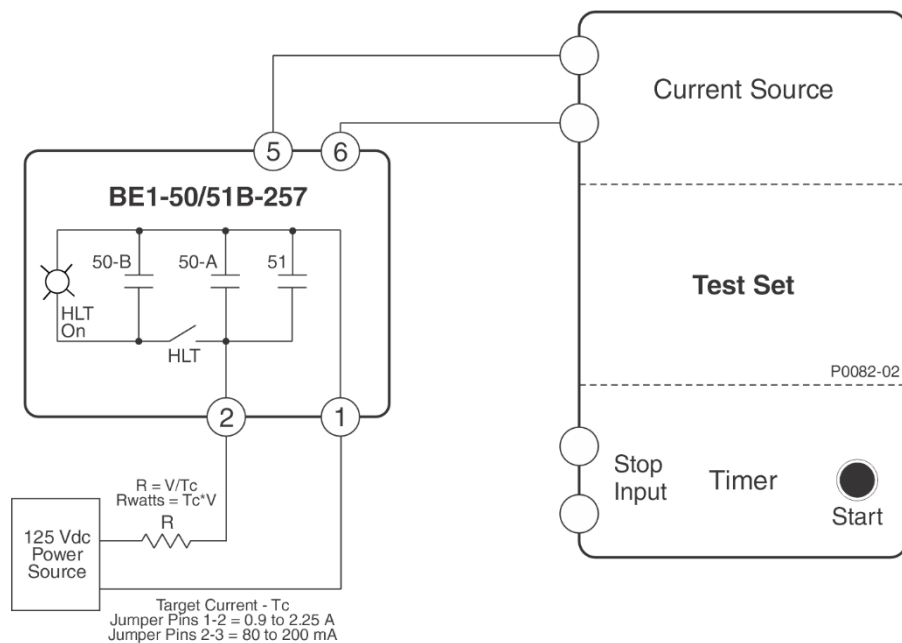

Figure 5-2. Target Indicator Test Setup

6 • Specifications

BE1-50/51B-257 electrical and physical specifications are listed in the following paragraphs.

Operational Specifications

Time Overcurrent (51) Element

Pickup

Setting Range 0.5 to 15.9 Aac
 Setting Increment 0.1 Aac
 Accuracy Sum of $\pm 2\%$ and ± 25 mAac

Dropout

Dropout occurs at 95% of pickup value.

Characteristic Curves

Available curve types follow IEEE Standard C37.112 (1996) and emulate standard GE IAC, ABB CO, and BS142 curves. The *Time Characteristic Curves* chapter illustrates the available curves and lists the applicable constants.

Curve Types Short Inverse, Long Inverse, Definite Time, Moderately Inverse, Inverse, Very Inverse, Extremely Inverse, BS142 Very Inverse, BS142 Extremely Inverse, Fixed Time
 Time Multiplier 11 curves for each characteristic
 Timing Accuracy The sum of ± 1 cycle and $\pm 2\%$ for the range of 2 to 40 times tap for a given measured multiple of tap. The timing accuracy is the sum of ± 2 cycles and $\pm 2\%$ for the range of 1.3 to 2 times tap and is for a given measured multiple of tap.

Fixed Timing

Setting Range 0.1 to 9.9 s
 Setting Increment 0.1 s

Reset

Integrating Simulates the disk reset of electromechanical relays and begins when the current decreases below 95% of pickup. The *Time Characteristic Curves* chapter illustrates the integrating reset characteristic curve and equation.
 Instantaneous Reset occurs when current decreases to 95% of the pickup level with no intentional time delay.

Instantaneous Overcurrent A (50-A) Element

Note

At least 2 A is required to energize both instantaneous elements at the same time. Therefore, only one instantaneous element can be set below 2 A.

Pickup

Setting Range 1 to 99 Aac
 Setting increment 1 Aac
 Accuracy Sum of $\pm 2\%$ and ± 25 mAac

Dropout

Dropout occurs at 95% of pickup value.

Time Delay

Switch selectable—no intentional delay (SW3-2 OFF) or a fixed delay of 100 ms (SW3-2 ON). The *Time Characteristic Curves* chapter illustrates the characteristic curve for the 50-A and 50-B elements.

Instantaneous Overcurrent B (50-B) Element**Note**

At least 2 A is required to energize both instantaneous elements at the same time. Therefore, only one instantaneous element can be set below 2 A.

Pickup

Setting Range 1 to 15.9 Aac
 Setting increment 0.1 Aac
 Accuracy Sum of $\pm 2\%$ and ± 25 mAac

Dropout

Dropout occurs at 95% of pickup value.

Time Delay

Fixed at no intentional delay. The *Time Characteristic Curves* chapter illustrates the characteristic curve for the 50-A and 50-B elements.

Reset Characteristic

Resets within 16 ms of when sensed current decreases below the pickup level.

Current Sensing Input

Continuous Rating 14 Aac*
 1 Second Rating 400 Aac
 * Continuous rating is 14 Aac for temperatures up to 45°C. See Figure 6-1 for the derating curve.

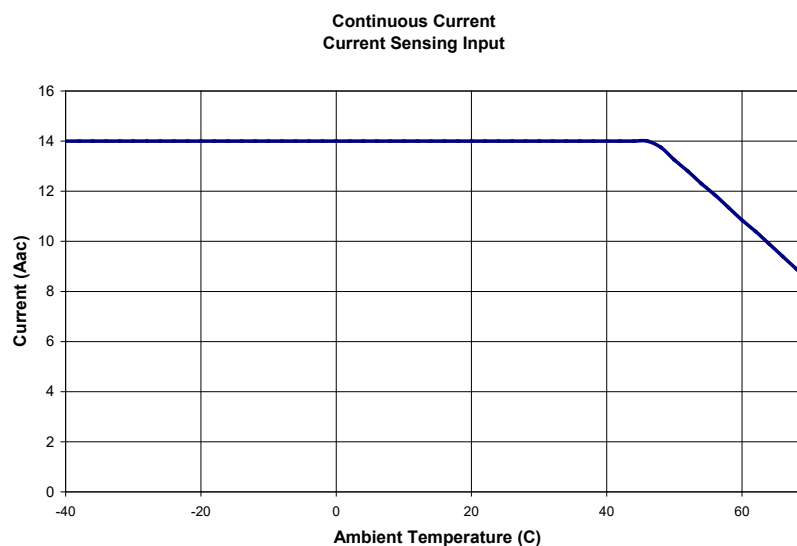

Figure 6-1. Current Sensing Input Derating Curve

Burden

Figure 6-2 illustrates the current sensing input burden characteristic.

At 0.5 amperesZ = 4.4 Ω

At 5.0 amperesZ = 0.2 Ω

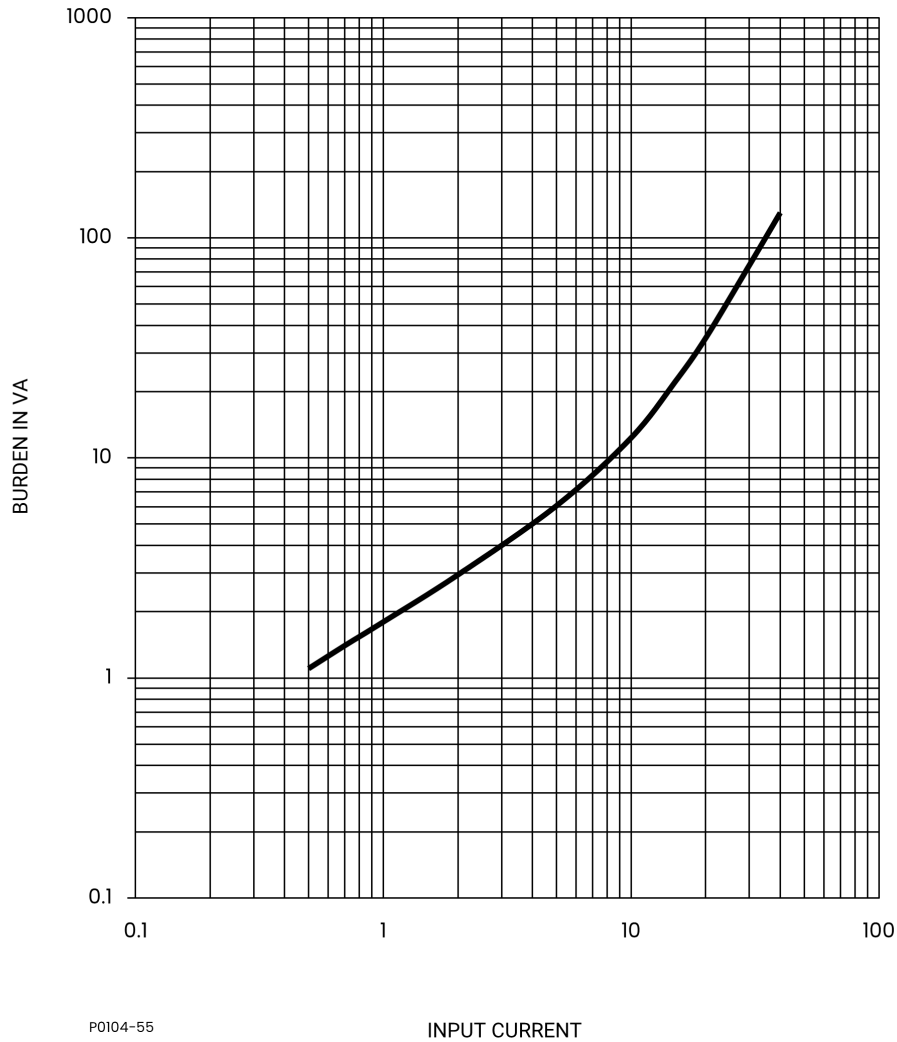

Figure 6-2. Current Sensing Input Burden

Frequency Response

A change of ±5 Hz from the nominal 50/60 Hz current causes <0.5% change in the current required for pickup.

Transient Response

<10% overreach with system time constants up to 40 ms.

Harmonic Rejection

Rejection of odd and even harmonics is illustrated in Figure 6-3.

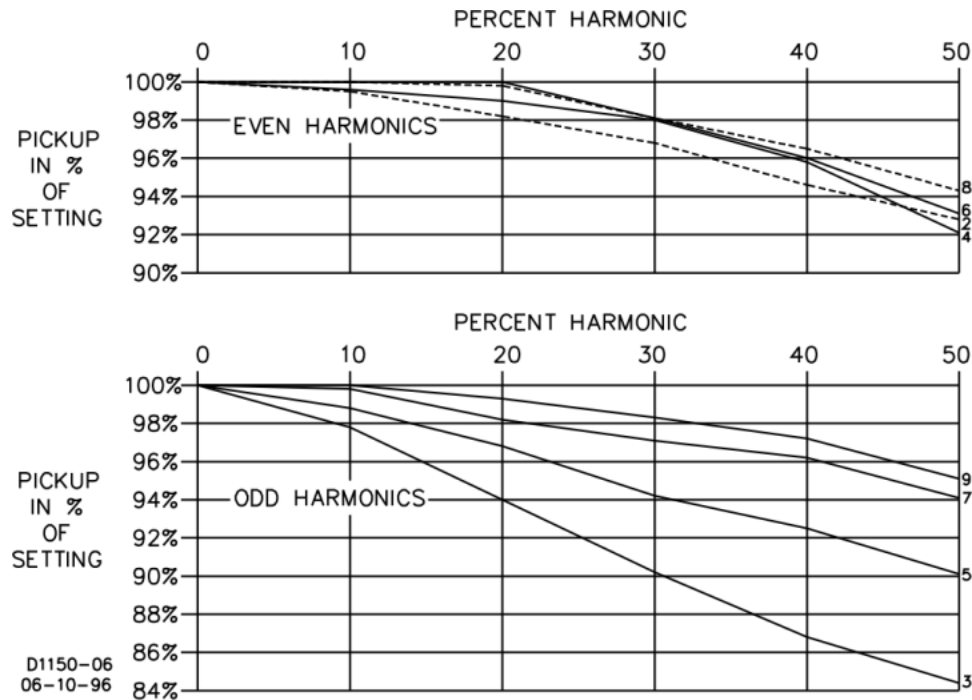

Figure 6-3. Harmonic Rejection

Target Indicators

Gravity-latched, manually-reset, current-operated target indicators are provided for the time-overcurrent (51) trip output and the instantaneous overcurrent A (50-A) trip output. A target indicator is not provided for the 50-B trip output. The level of trip circuit current required to operate each target is individually controlled by a circuit board jumper. See the *Controls and Indicators* chapter for jumper locations and function assignments.

Target Operate Current

- Jumper Position—Pins 1 and 2..... Must operate ≥ 2.25 A; must not operate < 900 mA. *
- Jumper Position—Pins 2 and 3..... Must operate ≥ 200 mA; must not operate < 80 mA. *

* See *Output Contacts* for the maximum acceptable levels of trip circuit currents.

Output Contacts

Output contacts are surge protected and rated as follows.

Resistive Ratings

- 120/240 Vac Make 30 amperes for 0.2 seconds, carry 7 amperes for 2 minutes, 3 amperes continuously, and break 5 amperes.
- 125/250 Vdc Make 30 amperes for 0.2 seconds, carry 7 amperes for 2 minutes, 3 amperes continuously, and break 0.3 ampere.

Inductive Ratings

- 120/240 Vac, 125/250 Vdc..... Make and carry 30 amperes for 0.2 seconds, carry 7 amperes for 2 minutes, 3 amperes continuously, and break 0.3 ampere. (L/R = 0.04).

Terminal Assignments

51 Element	1, 2
50-A Element	1, 2
50-B Element	1, 2

Type Tests

Isolation	IEEE C37.90 - 2005
Transient Surge	IEEE C37.90.1 - 2004
Radiated Interference	IEEE C37.90.2 - 2004
Electrostatic Discharge	IEEE C37.90.3 - 2006
Vibration	IEC 255-21-1
Shock and Bump	IEC 255-21-2

Environment

Operating Temperature	-40 to 70°C (-40 to 158°F)
Storage Temperature	-50 to 70°C (-58 to 158°F)

FCC Requirements

This product complies with FCC 47 CFR Part 15.

China RoHS

The following table serves as the declaration of hazardous substances for China in accordance with PRC standard SJ/T 11364-2014. The EFUP (Environment Friendly Use Period) for this product is 40 years.

PRODUCT: BE1-50/51B										
零件名称 Part Name	有害物质 Hazardous Substances									
	铅 Lead (Pb)	汞 Mercury (Hg)	镉 Cadmium (Cd)	六价铬 Hexavalent Chromium (Cr ⁶⁺)	多溴联苯 Polybrominated Biphenyls (PBB)	多溴二苯醚 Polybrominated Diphenyl Ethers (PBDE)	邻苯二甲 酸二丁酯 Dibutyl Phthalate (DBP)	邻苯二甲 酸丁苄酯 Benzyl butyl phthalate (BBP)	邻苯二甲 酸二酯 Bis(2- ethylhexyl) phthalate (BEHP)	邻苯二甲 酸二异丁 酯 Diisobutyl phthalate (DIBP)
金属零件 Metal parts	X	O	X	O	O	O	O	O	O	O
聚合物 Polymers	O	O	O	O	O	X	O	O	O	O
电子产品 Electronics	X	O	X	O	O	O	O	O	O	O
电缆和互连 配件 Cables & interconnect accessories	X	O	O	O	O	O	O	O	O	O
绝缘材料 Insulation material	O	O	O	O	O	O	O	O	O	O

本表格依据 SJ/T11364 的规定编制。

O: 表示该有害物质在该部件所有均质材料中的含量均在 GB/T 26572 规定的限量要求以下。

X: 表示该有害物质至少在该部件的某一均质材料中的含量超出 GB/T 26572 规定的限量要求。

This form was prepared according to the provisions of standard SJ/T11364.

O: Indicates that the hazardous substance content in all homogenous materials of this part is below the limit specified in standard GB/T 26252.

X: Indicates that the hazardous substance content in at least one of the homogenous materials of this part exceeds the limit specified in standard GB/T 26572.

Physical

Weight 6.1 lb (2.77 kg)

7 • Time Characteristic Curves

This chapter describes and defines the instantaneous overcurrent, time overcurrent, and integrating time reset characteristics of the BE1-50/51B-257 relay.

Instantaneous Overcurrent Characteristics

Timing

The instantaneous characteristic curves of the BE1-50/51B-257 relay are similar to standard electromechanical instantaneous units. However, the time to trip for applications where the initial sensing current is less than 400 mA may be slightly longer. This may occur on a very lightly loaded circuit or when the relay is providing ground protection and is connected to measure neutral current. Figure 7-1 shows the instantaneous characteristic curves for the maximum time to trip.

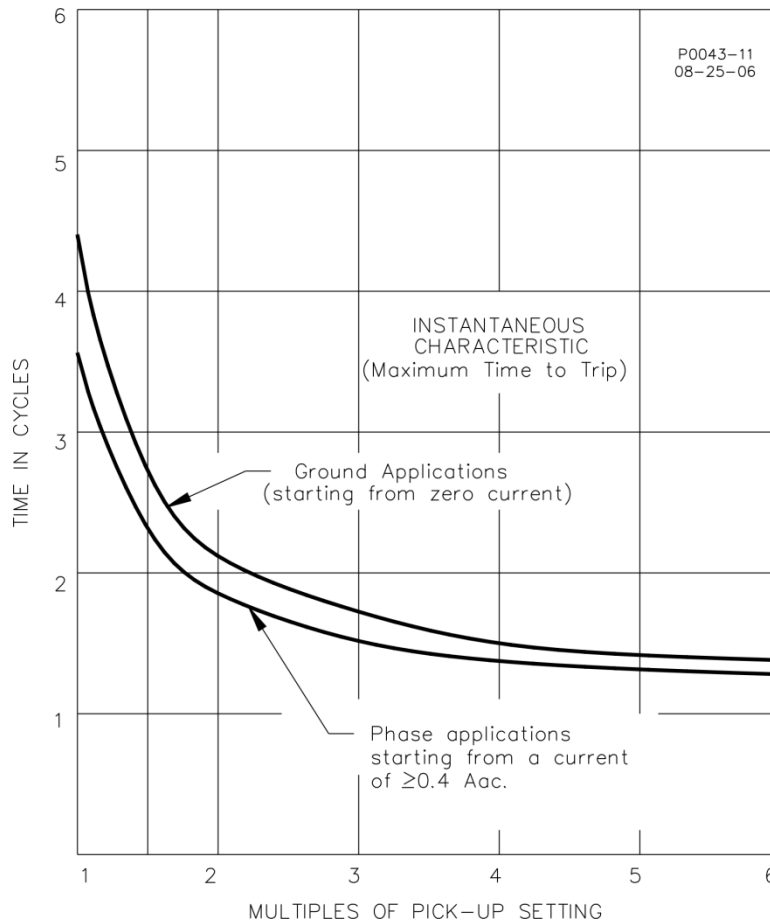

Figure 7-1. Instantaneous Characteristic Curves

The delay of the Instantaneous A (50-A) element can be set for no intentional delay (switch SW3-2 open) or an additional delay of 100 ms (SW3-2 closed). Refer to the *Controls and Indicators* chapter for the location of SW3. The time delay of the 50-B element is not switch-selectable and is fixed at no intentional delay.

Pickup

The instantaneous elements of the BE1-50/51B-257 relay may be set lower than the instantaneous element in IAC relays and still have the same reach. This is because the BE1-50/51B-257 instantaneous elements effectively eliminate the fault current transient overreach components. When setting the

BE1-50/51B-257 instantaneous elements, calculate the symmetrical value without any adder for transient overreach.

Time Overcurrent Characteristics

Nine inverse time functions and one fixed (definite) time function can be selected at the front panel. Curve types are identified by a letter designator. Available curve types are short inverse (S), long inverse (L), definite time (D), moderately inverse (M), inverse (I), very inverse (V), extremely inverse (E), BS142 inverse (B), and BS142 extremely inverse (C).

Inverse Time Functions

Characteristic curves for the inverse and definite time functions are defined by the following equation:

$$T_T = \frac{AD}{M^N - C} + BD + K$$

Where: T_T = time to trip in seconds
 D = time dial setting
 M = multiple of pickup setting
 A, B, C, N, K = constants for the particular curve

Characteristic Curve Groups

Either GE IAC or ABB characteristic curve groups are selected through switch SW3-3. (Refer to the *Controls and Indicators* chapter for the location of SW3.)

Characteristic Curve Constants

Tables 7-1 and 7-2 list the time characteristic curve constants used by the relay. Constants have been selected to conform to the characteristics of electromechanical relays over a range of pickup multiples from 1.3 to 40. Values of the constants are provided for use in PC relay setting applications. Timing accuracy is ± 1 cycle $\pm 2\%$ of time to trip.

Table 7-1. Time Characteristic Curve Constants with Switch SW3-3 Open (Off)

Curve Type	Similar To	Figure Number	Constants					
			A	B	C	N	K	R
S	ABB CO-2	7-2	0.2663	0.03393	1.000	1.2969	0.028	0.500
L	ABB CO-5	7-3	5.6143	2.18592	1.000	1.0000	0.028	15.750
D	ABB CO-6	7-4	0.4794	0.21359	1.000	1.5625	0.028	0.875
M	ABB CO-7	7-5	0.3022	0.12840	1.000	0.5000	0.028	1.750
I	ABB CO-8	7-6	8.9341	0.17966	1.000	2.0938	0.028	9.000
V	ABB CO-9	7-7	5.4678	0.10814	1.000	2.0469	0.028	5.500
E	ABB CO-11	7-8	7.7624	0.02758	1.000	2.0938	0.028	7.750
B	BS142-B*	7-9	1.4636	0.00000	1.000	1.0469	0.028	3.250
C	BS142-C*	7-10	8.2506	0.00000	1.000	2.0469	0.028	8.000
F	None†	None	0.0000	1.00000	0.000	0.0000	0.000	1.000

* Curves B and C are defined in British Standard BS142 and IEC 255-4 (International Electrotechnical Commission).

† Fixed time from 0.1 to 9.9 seconds.

Table 7-2. Time Characteristic Curve Constants with Switch SW3-3 Closed (On)

Curve Type	Similar To	Figure Number	Constants					
			A	B	C	N	K	R
S	GE IAC 55	7-11	0.0286	0.0208	1.000	0.9844	0.028	0.0940
L	GE IAC 66	7-12	2.3955	0.00002	1.000	0.3125	0.028	7.8001
D	ABB CO-6	7-4	0.4797	0.21359	1.000	1.5625	0.028	0.8750
M	ABB CO-7	7-5	0.3022	0.12840	1.000	0.5000	0.028	1.7500
I	GE IAC 51	7-13	0.2747	0.1042	1.000	0.4375	0.028	0.8868
V	GE IAC 53	7-14	4.4309	0.0991	1.000	1.9531	0.028	5.8231
E	GE IAC 77	7-15	4.9883	0.0129	1.000	2.0469	0.028	4.7742
B	BS142-B*	7-9	1.4636	0.00000	1.000	1.0469	0.028	3.2500
C	BS142-C*	7-10	8.2506	0.00000	1.000	2.0469	0.028	8.0000
F	None†	None	0.0000	1.00000	0.000	0.0000	0.000	1.0000

* Curves B and C are defined in British Standard BS142 and IEC 255-4 (International Electrotechnical Commission).

† Fixed time from 0.1 to 9.9 seconds.

Figures 7-2 through 7-15 illustrate the characteristic curves that are programmed into the nonvolatile memory of the BE1-50/51B-257.

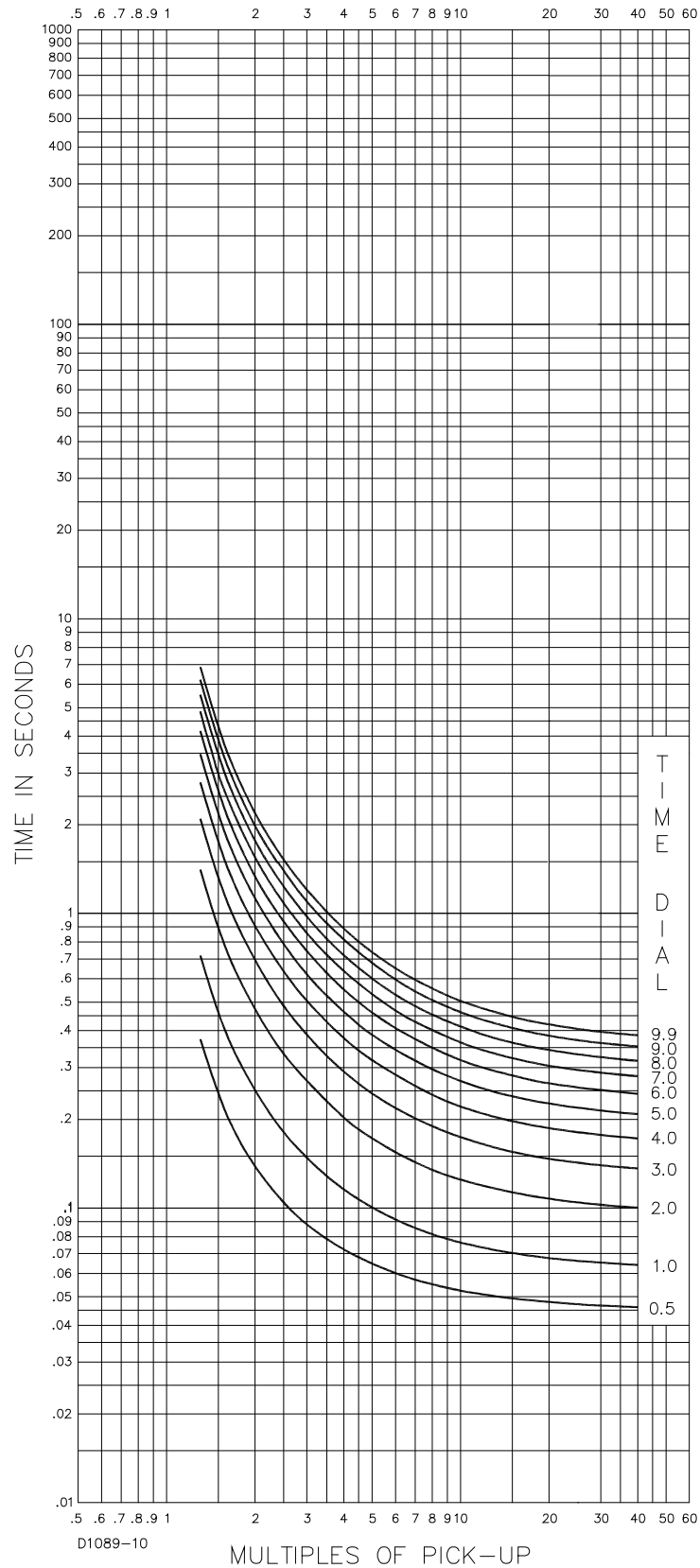

Figure 7-2. Time Characteristic Curve, S-Short Inverse (SW3-3 OFF, Similar to ABB CO-2)

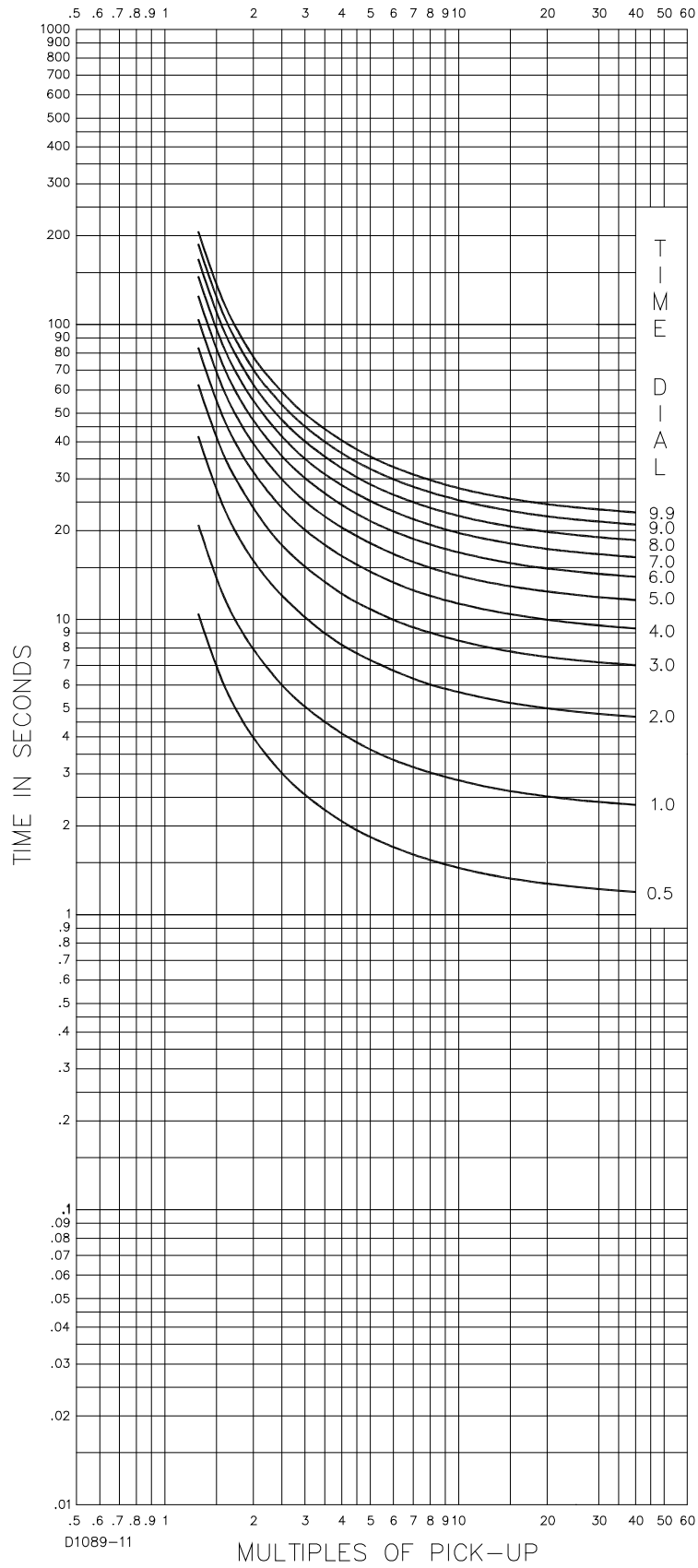

Figure 7-3. Time Characteristic Curve, L-Long Inverse (SW3-3 OFF, Similar to ABB CO-5)

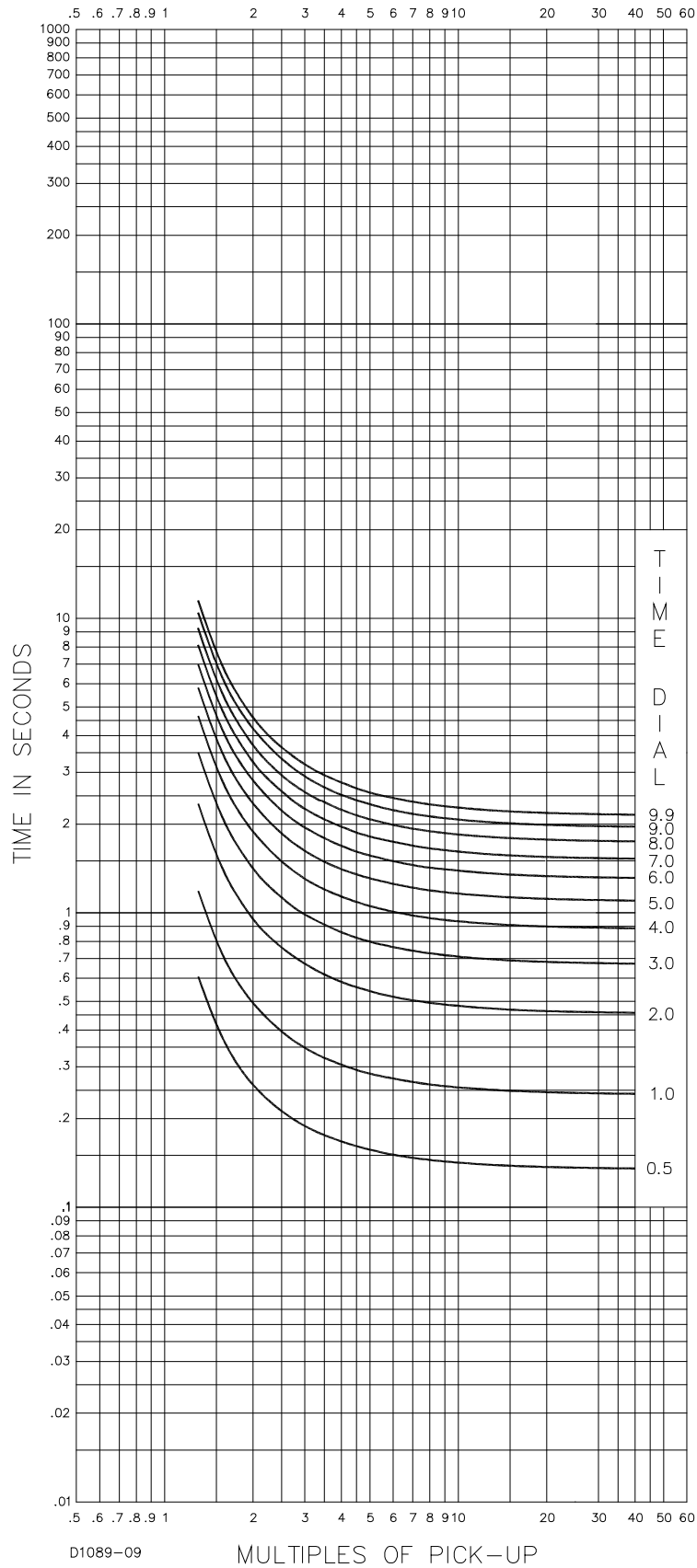

Figure 7-4. Time Characteristic Curve, D-Definite Time (Similar to ABB CO-6)

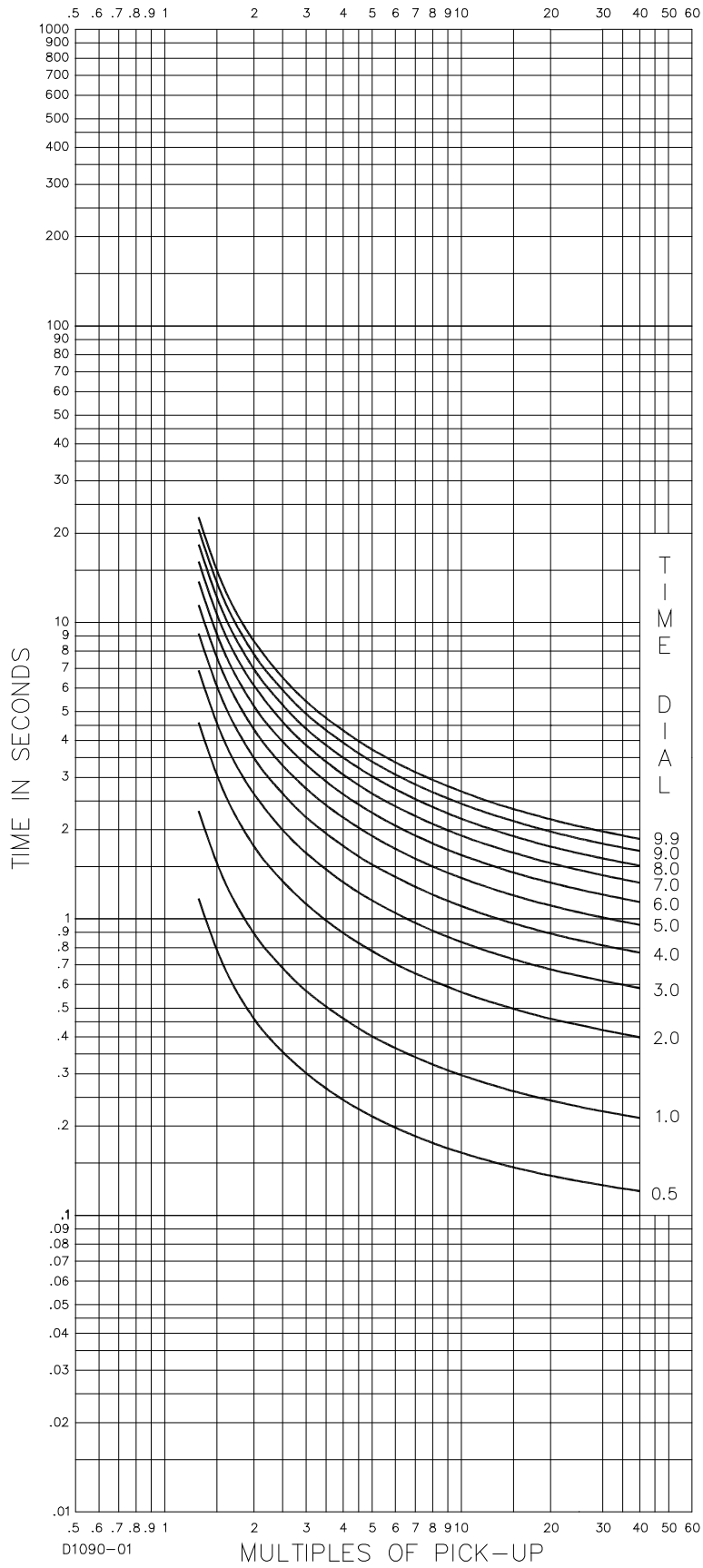

Figure 7-5. Time Characteristic Curve, M-Moderately Inverse (Similar to ABB CO-7)

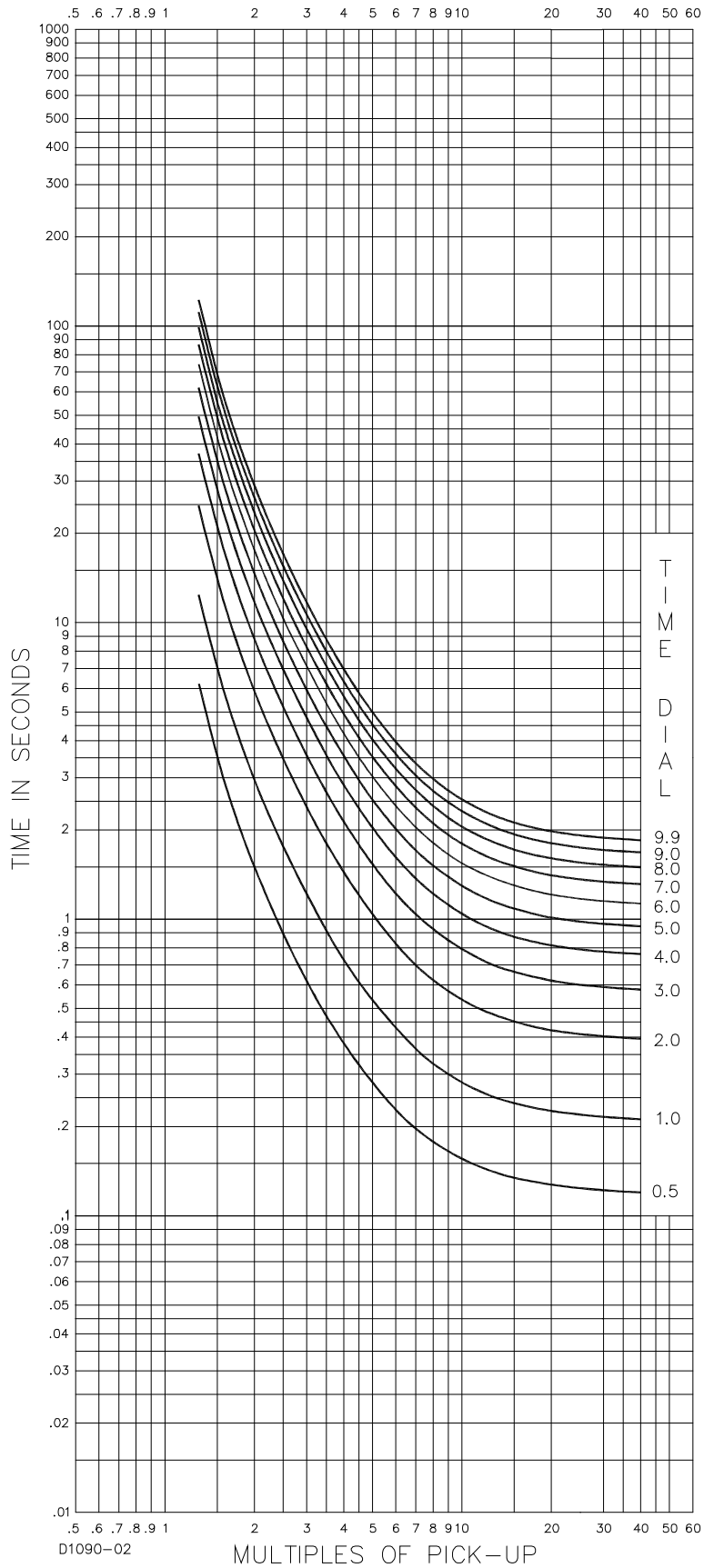

Figure 7-6. Time Characteristic Curve, I-Inverse (SW3-3 OFF, Similar to ABB CO-8)

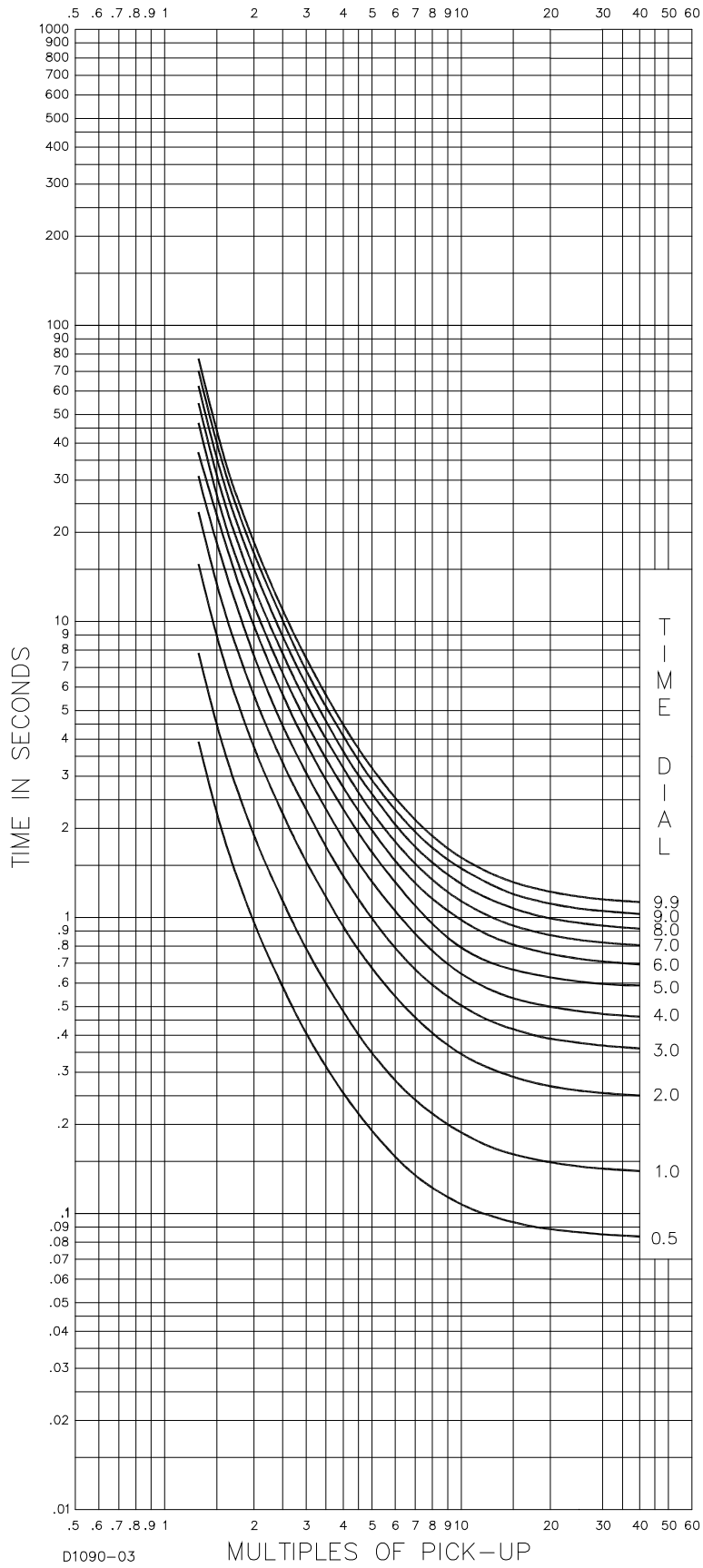

Figure 7-7. Time Characteristic Curve, V-Very Inverse (SW3-3 OFF, Similar to ABB CO-9)

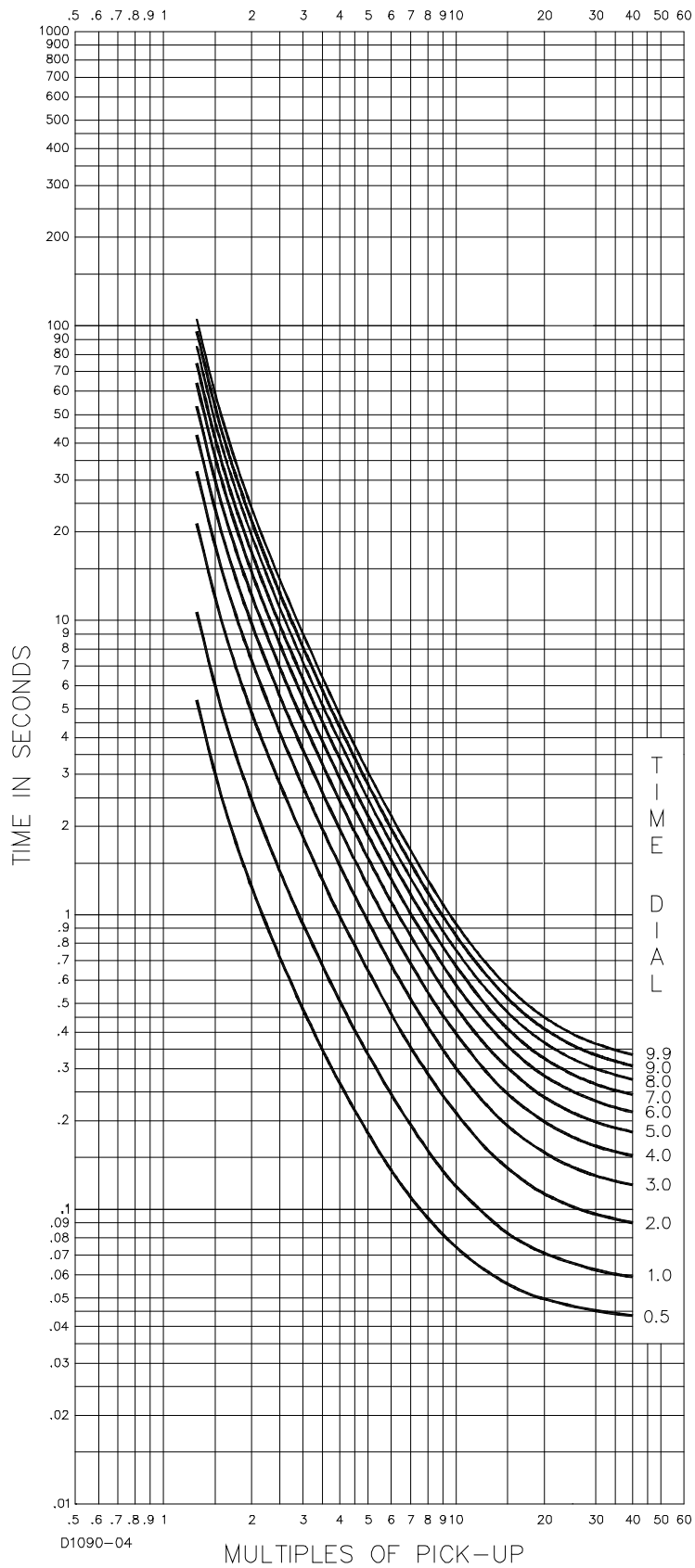

Figure 7-8. Time Characteristic Curve, E-Extremely Inverse (SW3-3 OFF, Similar to ABB CO-11)

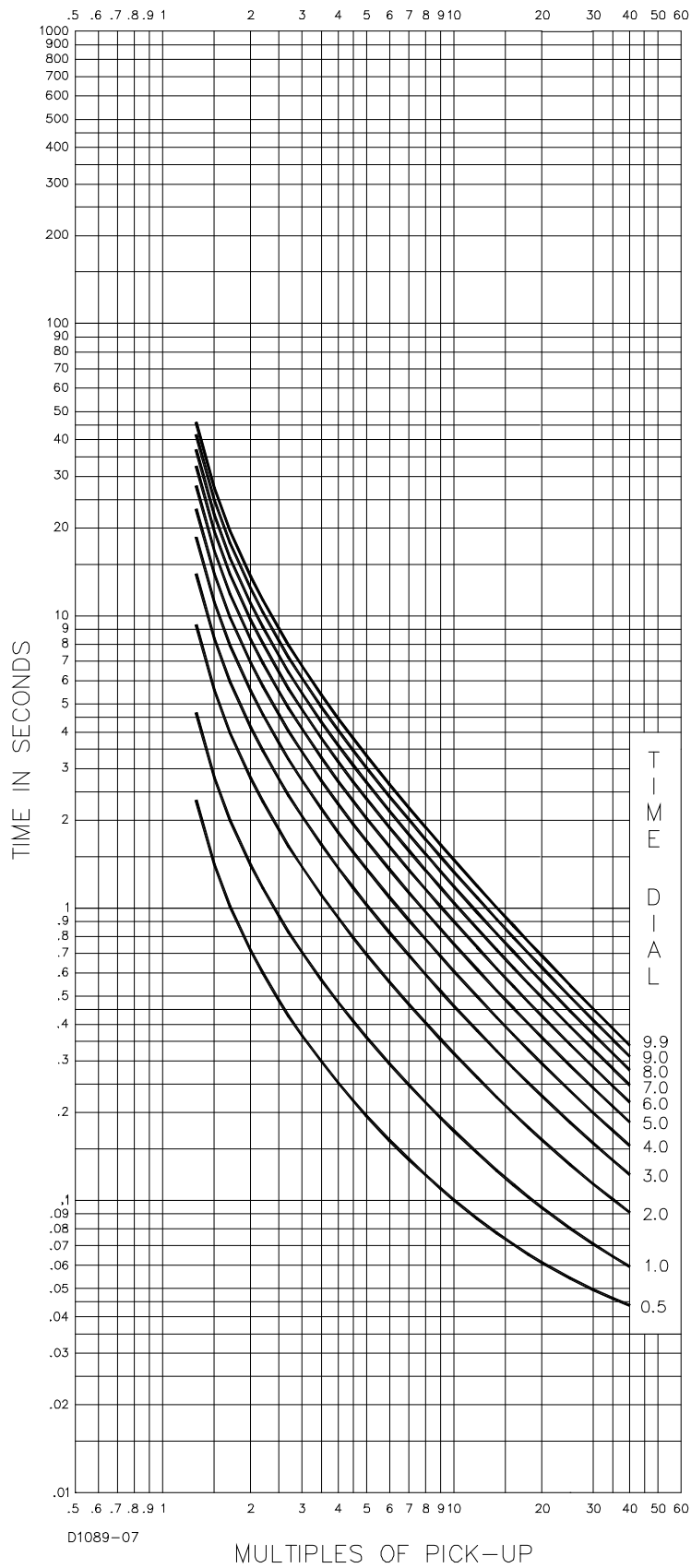

Figure 7-9. Time Characteristic Curve, BS142-B (BS142 Very Inverse)

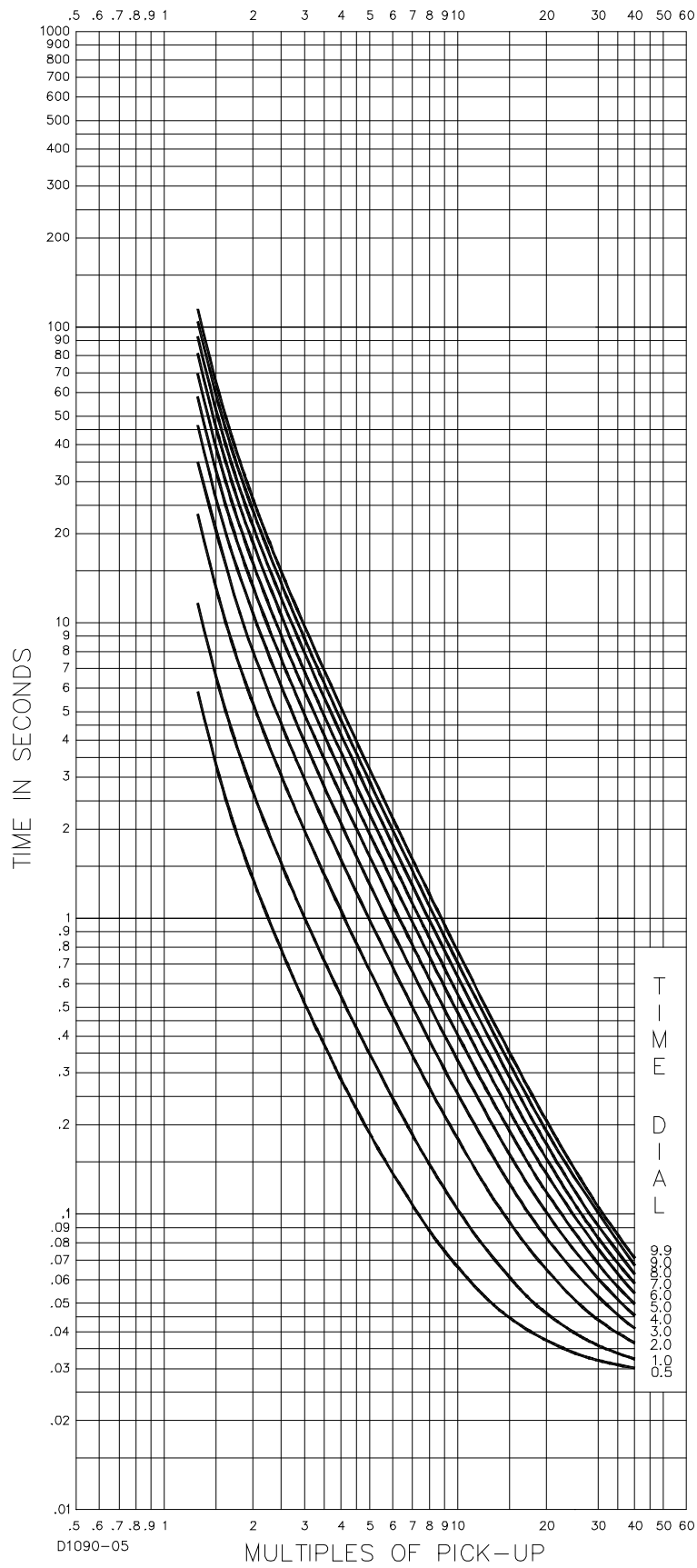

Figure 7-10. Time Characteristic Curve, BS142-C (BS142 Extremely Inverse)

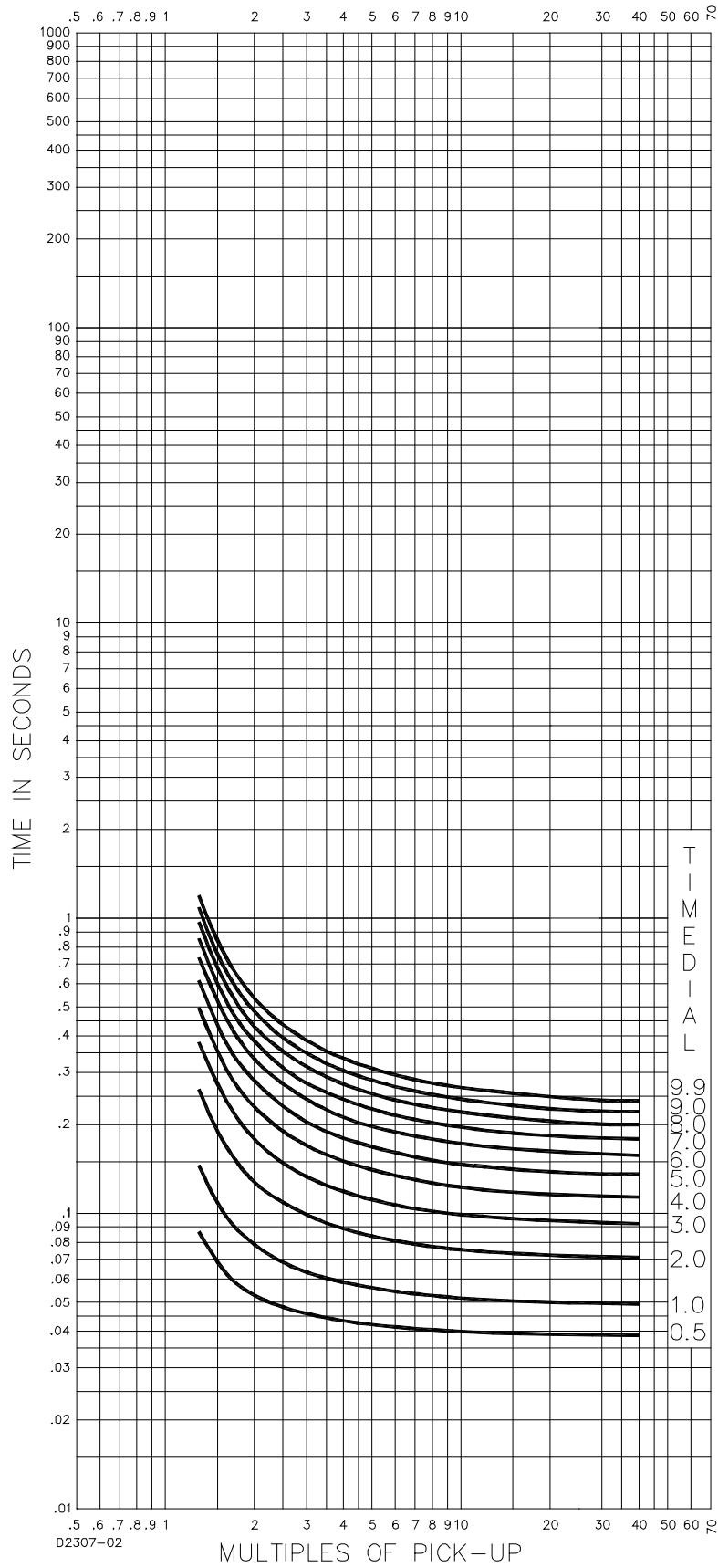

Figure 7-11. Time Characteristic Curve, S2-Short Inverse (SW3-3 ON, Similar to GE IAC 55)

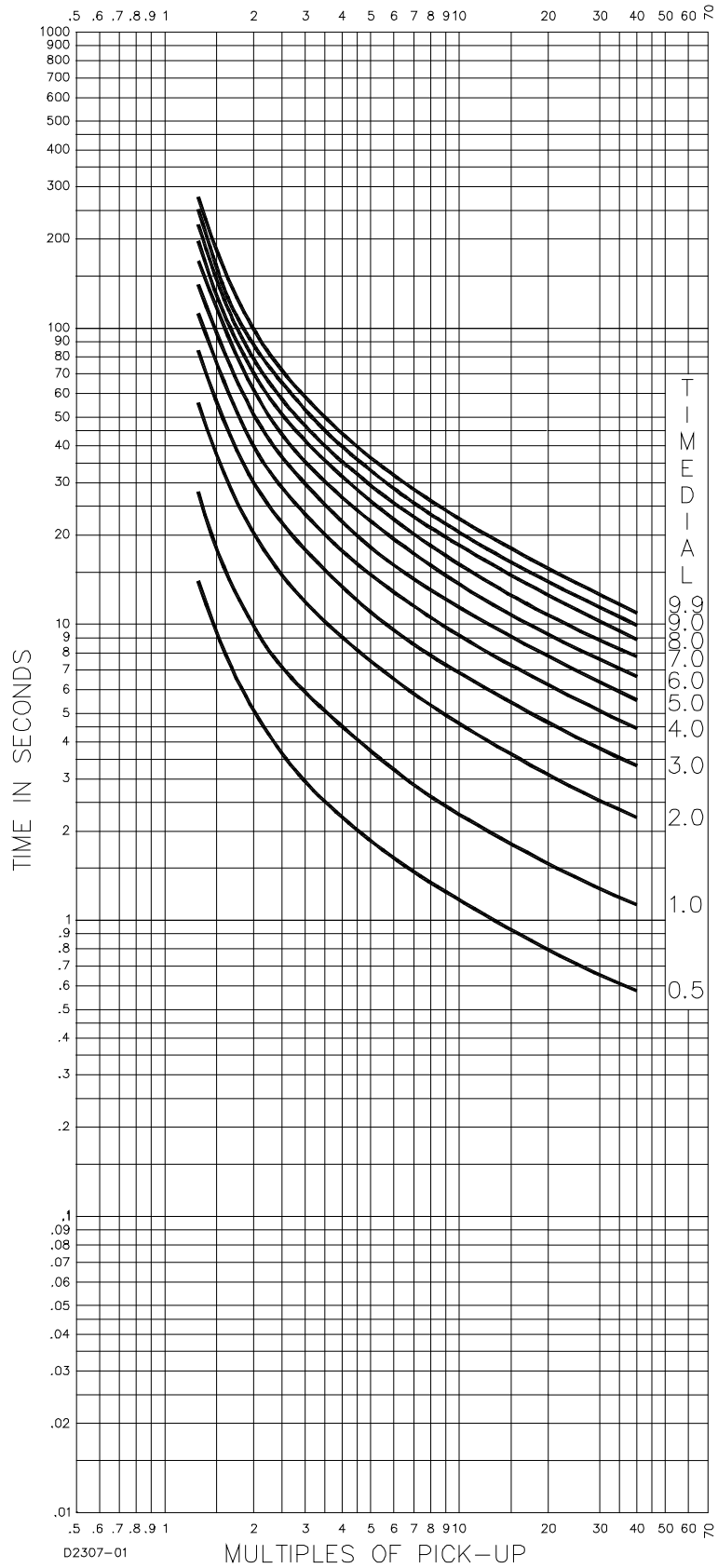

Figure 7-12. Time Characteristic Curve, L2-Long Inverse (SW3-3 ON, Similar to GE IAC 66)

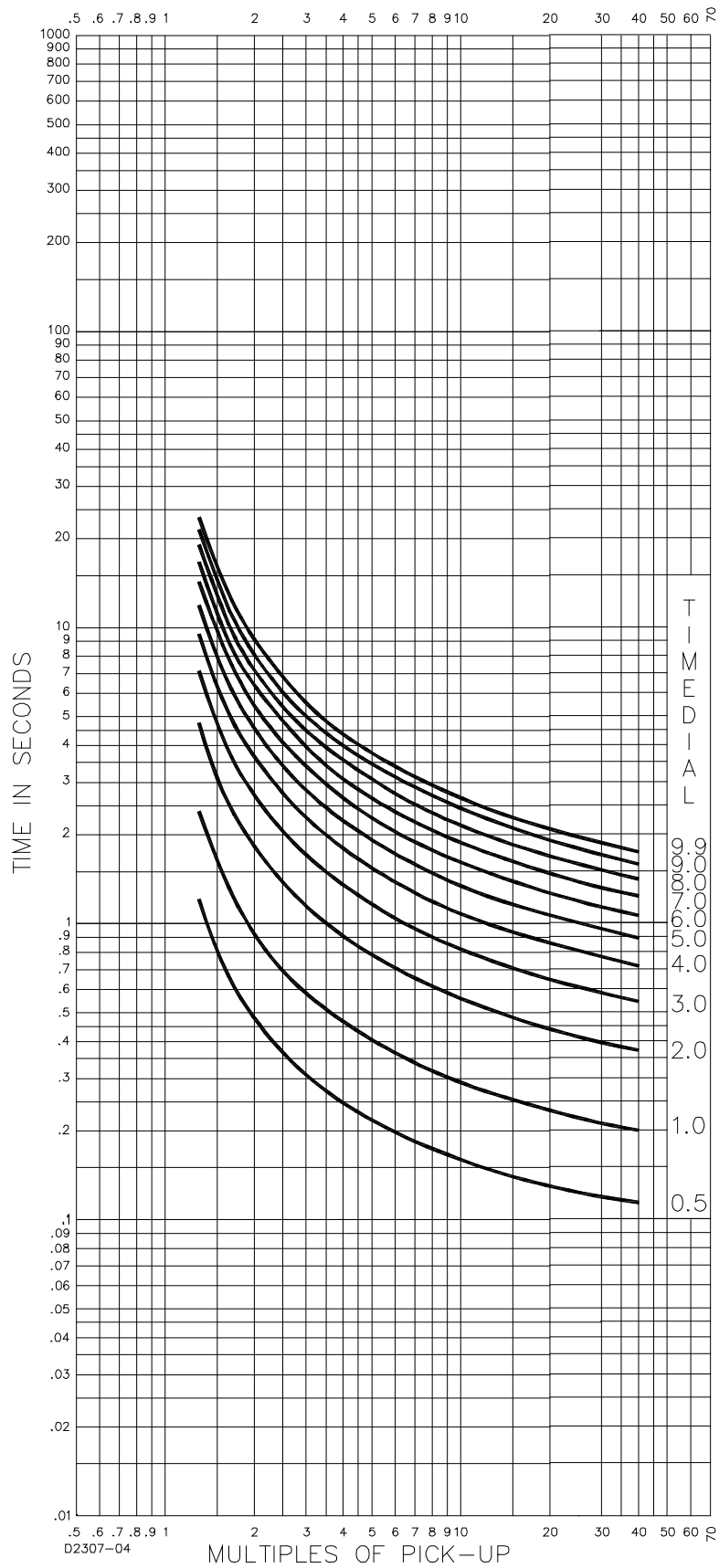

Figure 7-13. Time Characteristic Curve, I2-Inverse (SW3-3 ON, Similar to GE IAC 51)

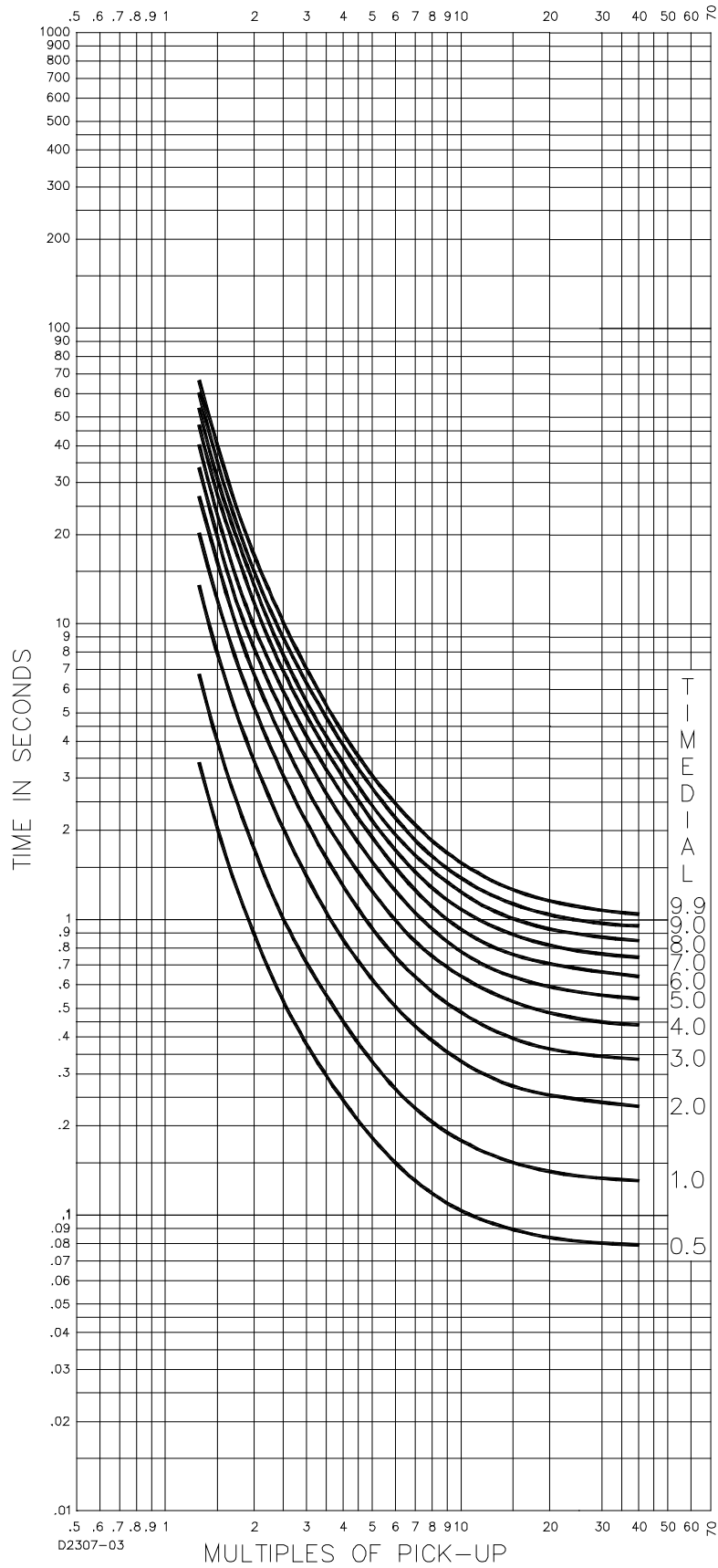

Figure 7-14. Time Characteristic Curve, V2-Very Inverse (SW3-3 ON, Similar to GE IAC 53)

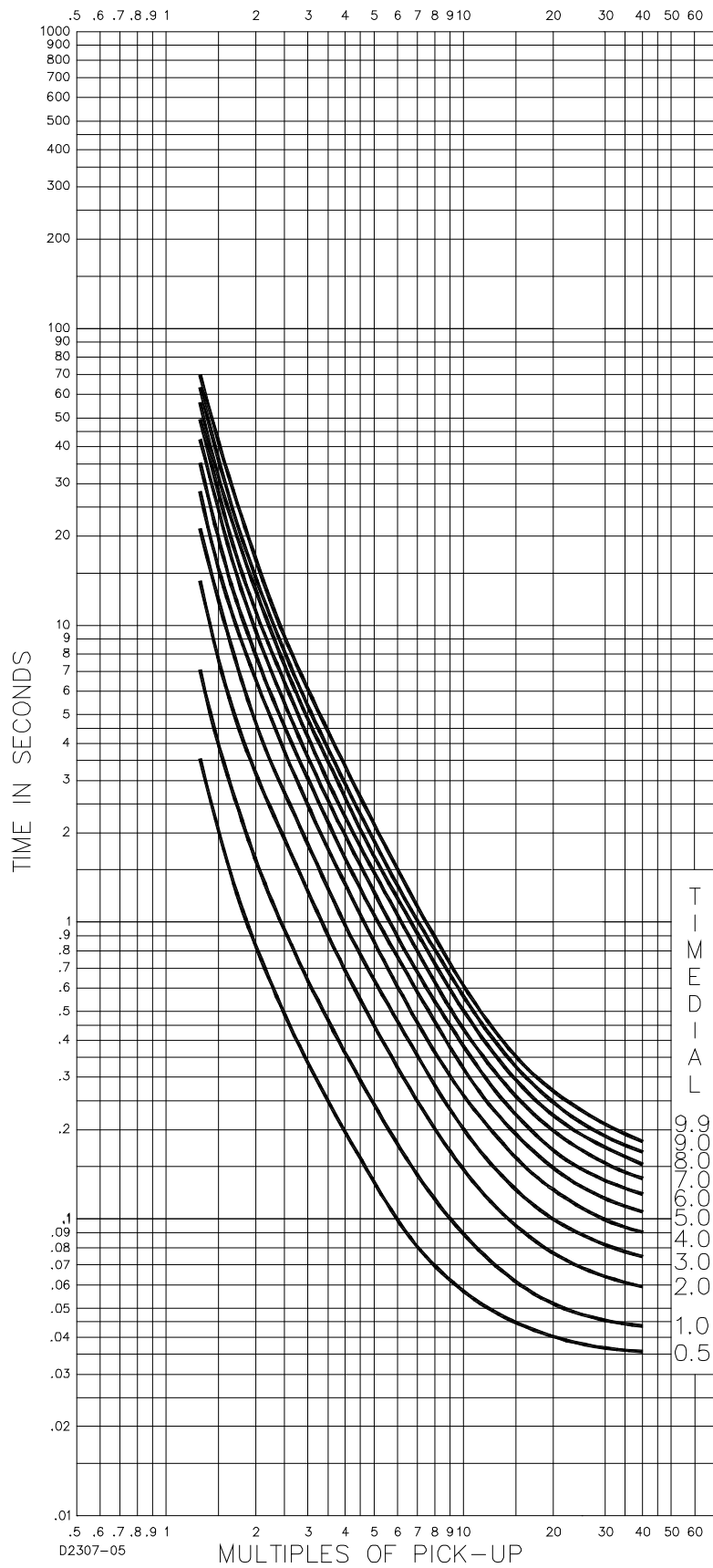

Figure 7-15. Time Characteristic Curve, E2-Extremely Inverse (SW3-3 ON, Similar to GE IAC 77)

Integrating Time Reset Characteristic

The relay can be user-configured for integrating or instantaneous type reset.

Integrating reset simulates the disk reset of electromechanical relays and begins when the current decreases below 95% of pickup. BE1-50/51B-257 relays provide the integrating reset function even when input current decreases to zero.

Integrating reset characteristics are defined by the following equation and are illustrated in Figure 7-16. See Tables 7-1 and 7-2 for the equation constants.

$$T_R = \frac{RD}{M^2 - 1}$$

Where:

T_R = time to reset in seconds
 R = constant for the particular curve
 D = time dial setting
 M = current in multiples of pickup setting during reset

Time characteristic curve equation:

$$T_T = \frac{AD}{M^N - C} + BD + K = \text{Time to Trip}$$

Where:

D = time dial setting
 M = multiple of pickup setting

Reset characteristic curve equation:

$$T_R = \frac{RD}{M^2 - 1} = \text{Time to Reset}$$

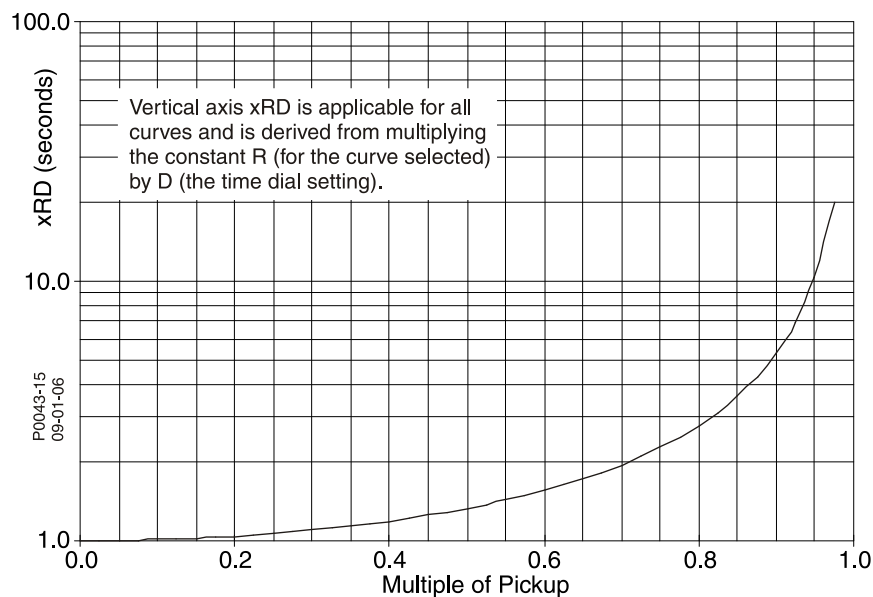

Figure 7-16. Integrating Reset Characteristic Curve



Highland, Illinois USA
Tel: +1 618.654.2341
Fax: +1 618.654.2351
email: info@basler.com

Suzhou, P.R. China
Tel: +86 512.8227.2888
Fax: +86 512.8227.2887
email: chinainfo@basler.com