

INSTRUCTION MANUAL

for

BE1-24

VOLTS PER HERTZ OVEREXCITATION RELAY

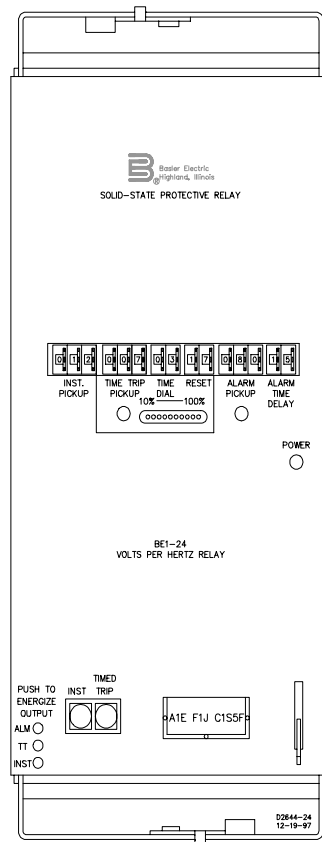

Basler Electric

Publication: 9 1716 00 990
Revision: E 08/98

INTRODUCTION

This Instruction Manual provides information concerning the operation and installation of BE1-24 Volts per Hertz Overexcitation Relay. To accomplish this, the following is provided.

- Specifications
- Functional characteristics
- Installation
- Operational Tests
- Mounting Information

WARNING

To avoid personal injury or equipment damage, only qualified personnel should perform the procedures presented in this manual.

First Printing: May 1988

Printed in USA

© 1995, 1998 Basler Electric Co., Highland, IL 62249

August 1998

CONFIDENTIAL INFORMATION

OF BASLER ELECTRIC COMPANY, HIGHLAND, IL. IT IS LOANED FOR CONFIDENTIAL USE, SUBJECT TO RETURN ON REQUEST, AND WITH THE MUTUAL UNDERSTANDING THAT IT WILL NOT BE USED IN ANY MANNER DETRIMENTAL TO THE INTEREST OF BASLER ELECTRIC COMPANY.

It is not the intention of this manual to cover all details and variations in equipment, nor does this manual provide data for every possible contingency regarding installation or operation. The availability and design of all features and options are subject to modification without notice. Should further information be required, contact Basler Electric Company, Highland, Illinois.

**BASLER ELECTRIC
ROUTE 143, BOX 269
HIGHLAND, IL 62249 USA**

<http://www.basler.com>, info@basler.com

PHONE 618-654-2341

FAX 618-654-2351

CONTENTS

SECTION 1	GENERAL INFORMATION	1-1
	Purpose.....	1-1
	Overexcitation	1-1
	Volts Per Hertz Principle	1-1
	Relay Characteristics	1-2
	Applications.....	1-2
	Model And Style Number	1-6
	Sample Style Number.....	1-6
	Specifications	1-8
SECTION 2	HUMAN-MACHINE INTERFACE	2-1
	Controls and Indicators	2-1
SECTION 3	FUNCTIONAL DESCRIPTION	3-1
	General	3-1
	Functional Description	3-1
	Thumbwheel Switches	3-1
	Input Sensing.....	3-1
	Third Harmonic Rejection Filter.....	3-2
	Microprocessor	3-2
	Trip Level Detector	3-2
	Digital-to-Analog Converter	3-2
	Output Functions.....	3-3
	Inverse Square Timing	3-3
	Definite Time Alarm	3-4
	Instantaneous Trip Output	3-4
	Outputs	3-4
	Timing Status Display	3-4
	Watchdog Circuitry.....	3-5
	Relay Fail Function	3-5
	Targets.....	3-5
	Built-In-Test.....	3-5
	Push-To-Energize-Output Pushbuttons.....	3-5
	Power Supply.....	3-5
SECTION 4	INSTALLATION.....	4-1
	General	4-1
	Relay Operating Precautions	4-1
	Dielectric Test	4-1
	Mounting	4-1
	Connections	4-8
SECTION 5	OPERATIONAL TEST.....	5-1
	General	5-1
	Relay Operating Precautions	5-1
	Built-In-Test.....	5-1
	Operational Test Procedures	5-1
	Pickup.....	5-2
	Instantaneous Time Verification	5-3
	Definite Time Delay Alarm.....	5-3
	Inverse Square Timing	5-4

CONTENTS - CONTINUED

SECTION 6	MAINTENANCE	6-1
	General	6-1
	In-House Repair.....	6-1
	Storage	6-1
	Test Plug.....	6-1
SECTION 7	MANUAL CHANGE INFORMATION	7-1
	Changes.....	7-1

SECTION 1 • GENERAL INFORMATION

PURPOSE

BE1-24 Volts Per Hertz Overexcitation Relays are specifically designed to protect transformers, generators and iron core reactors from the adverse effects of excessive heating resulting from overexcitation. Overexcitation exists whenever the per unit volts per hertz exceeds the equipment design limitations.

OVEREXCITATION

Overexcitation is excessive flux density in the magnetic core of the protected equipment. Once the magnetic core is at or near saturation, any increase in the applied voltage will cause the excess flux to travel outside the core through the air or the structural steel components. Structural steel components are not laminated, and stray flux in these components cause large eddy current losses and hysteresis losses. This generates excessive heat. Also, the excess flux through the air requires a large current in the winding which creates excessive heat.

Overexcitation of transformers, iron core reactors, and generators can cause severe damage. This overheating causes the deterioration of adjacent insulation, and if allowed to persist, will lead to equipment failure. Modern designs are especially sensitive to overexcitation because they operate with high flux densities. Overexcitation can result from an increase in voltage or a decrease in frequency.

VOLTS PER HERTZ PRINCIPLE

Protective relaying must determine the level of flux density from the secondaries of voltage and/or current transformers. The following demonstrates the relationship between the actual flux density, voltage, and frequency as monitored by the protective relays.

By Definition, Flux Density:
$$B = \frac{\phi}{A} \text{ (webers/meter}^2\text{)} \quad (1)$$

Faraday's Law:
$$e = N \frac{d\phi}{dt} \quad (2)$$

Therefore:
$$\phi = \frac{1}{N} \int e dt \quad (3)$$

Let:
$$e = \sqrt{2} E \sin(\omega t) \quad (4)$$

Then:
$$\phi = -\frac{\sqrt{2} E}{N\omega} \cos(\omega t) \quad (5)$$

And:
$$\phi_{\max} = \frac{\sqrt{2} E}{N\omega} = \frac{1}{\sqrt{2}} \frac{V}{\pi f N} \quad (6)$$

Therefore:
$$\phi_{\max} = \frac{1}{\sqrt{2}} \frac{V \text{ (volts)}}{\pi N f \text{ (hertz)}} \quad (7)$$

where:

- B is the flux density (webers/meter²)
- Φ is the flux (webers)
- λ is the flux linkage (weber-turns)
- ω is equal to $2 \pi f$
- A is the cross sectional area (meter²)
- N is the number of turns
- e is the instantaneous voltage
- E is the RMS voltage
- V is the applied voltage
- f is the frequency in hertz

From (6) and (7), it may appear that the peak flux is directly proportional to the voltage. This may lead to the conclusion that overvoltage protection is adequate. However, overvoltage relaying provides only limited overexcitation protection at or near the rated frequency. A significant reduction in frequency without a reduction in voltage has an effect similar to overvoltage. This can be seen with an examination of (7). The flux is directly proportional to the voltage and inversely proportional to the frequency. Thus, the overexcitation of magnetic circuits is directly proportional to the ratio between the voltage and frequency (volts/hertz).

For example, a transformer with a 1.1 per unit voltage design rating will be overexcited if the voltage exceeds 110% at the rated frequency or the frequency drops below 90.9% at the rated voltage.

RELAY CHARACTERISTICS

BE1-24 relay emulate heating and cooling characteristics of the protected equipment. By accumulating time towards tripping whenever the timed trip volts/hertz pickup setting is exceeded, the relays simulate heat build up within the protected equipment. Once heated, metal does not cool instantaneously. To accommodate this characteristic, the BE1-24 also has a linear reset characteristic which can be adjusted to follow the cooling rate of the protected equipment. So, as heat builds up and dissipates within the protected equipment due to overexcitation excursions, it is closely protected by the BE1-24 tripping and reset characteristics.

NOTE

Actual damage curves must be obtained from the equipment manufacturer for the particular equipment to be protected.

The definite time alarm feature allows even more effective use of the equipment by alerting operators that a potentially dangerous condition exists. Once alerted, the operator can take corrective action to prevent the necessity of a relay trip. Alternatively, the definite-time alarm output contact can be used to initiate automatic corrective action.

The optional instantaneous trip provides high-speed tripping for the most severe conditions.

APPLICATIONS

Volts/hertz overexcitation relays primarily protect directly connected generator unit step-up transformers. These transformers may be subjected to excessive volts/hertz during generator startup or shutdown, power system islanding, or remote load rejection.

Typically, the generator field is applied when the machine is above 90% of rated speed. If the field is applied early, or not removed soon enough, the terminal voltage may be much higher than appropriate for the actual frequency. Many generator automatic voltage regulators and excitation systems are equipped with a volts/hertz characteristic. BE1-24 relays protect associated step-up transformers from overexcitation caused by failure of the field application/removal scheme, or by failure of the automatic voltage regulator during start-up and shutdown.

An excessive load-to-generation ratio during power system islanding, or during local loss of generation, can create an underfrequency condition which may result in the overexcitation of the generator unit step-up transformer. The BE1-24 relay acts as backup protection for underfrequency relaying, and for volts/hertz

control functions which may be incorporated in the generator voltage regulator.

The sudden removal of load from a generator results in an increase in terminal voltage especially if a transmission line remains connected as the only load. The automatic voltage regulator should act to bring the voltage down to a safe level before equipment damage occurs. However, in the event of a regulator failure, the BE1-24 protects equipment from damage.

Load tap changing (LTC) transformers and line voltage regulators may be subjected to excessive volts/hertz during abnormal system frequency conditions. This is the inevitable consequence of their constant voltage control function. Failure of the LTC controller may result in a runaway condition producing dangerously high voltages. The BE1-24 provides close protection for such equipment while allowing a wide range of voltage control operations.

Figure 1-1 illustrates the advantage of applying the inverse square timing characteristic rather than the two-step protection scheme. This provides closer coordination and prevents unnecessary tripping of the protected equipment.

In this example, two steps of definite time delay overexcitation protection are applied to provide protection that approximates the transformer damage curve. One step is set for 110 percent and 60 seconds. The second step is set for 118 percent and 6 seconds. However, by using the inverse square characteristic, the damage curve can be even more closely approximated. The resulting protection is more closely coordinated with adequate margin. Note that the cross hatched area reveals the overprotected area that results from use of a two step scheme.

When a transformer and generator are to be protected by a single volts-per-hertz overexcitation relay, the overexcitation curves for both pieces of equipment must be considered. Figure 1-2 illustrates a situation where these two units have different characteristics and yet can both be protected by the BE1-24. Utilizing the alarm function (with its definite time delay), and in combination with the inverse square characteristic, the transformer generator combination may be protected with a single BE1-24 Volts-Per-Hertz Overexcitation Relay. If necessary, the instantaneous element can be set to a percentage (105%) of the rated excitation to provide an early warning alarm. This alarm can enable the operator controlling the excitation to recover and prevent tripping.

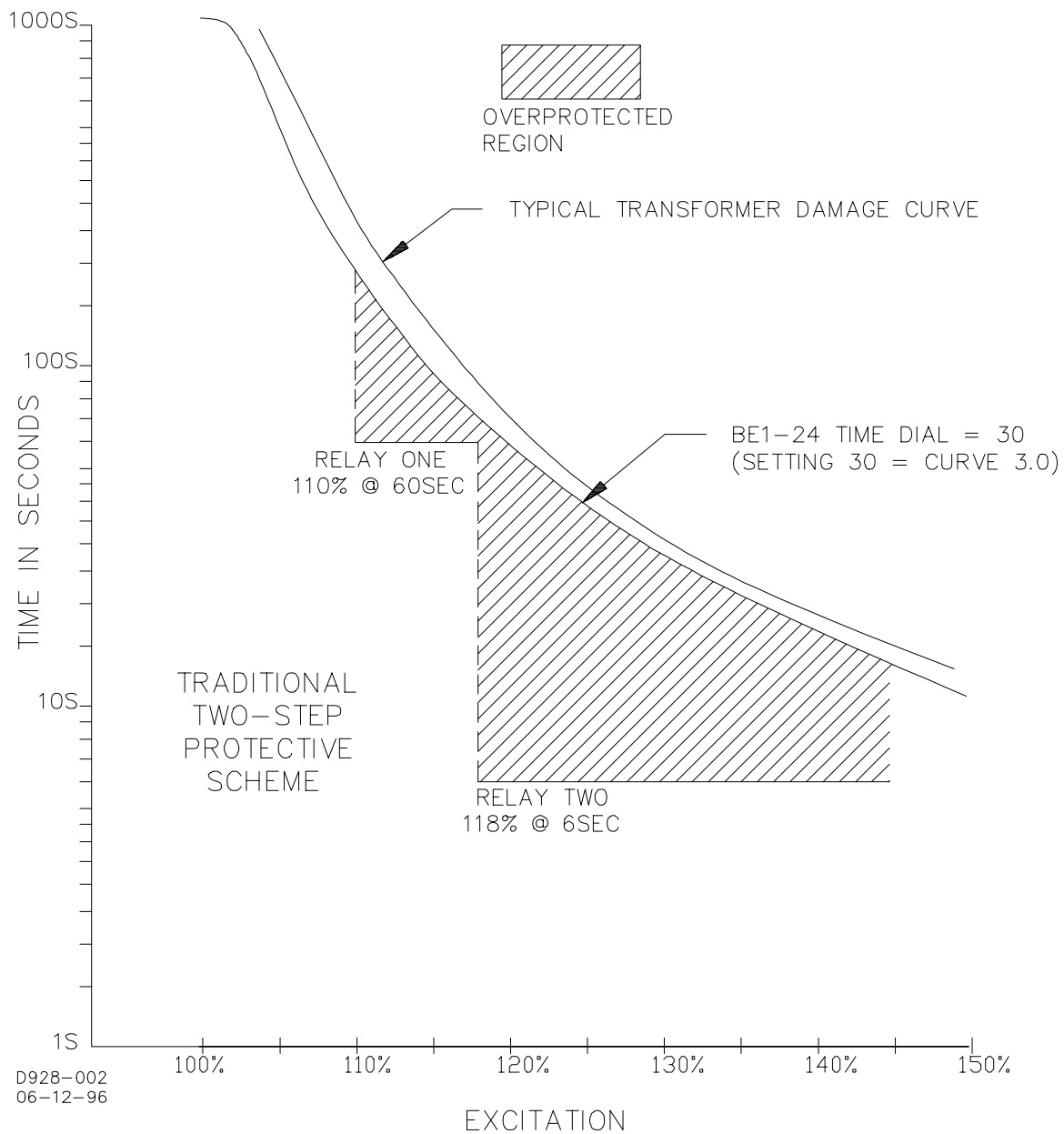

Figure 1-1. Inverse Square vs. Two-Step

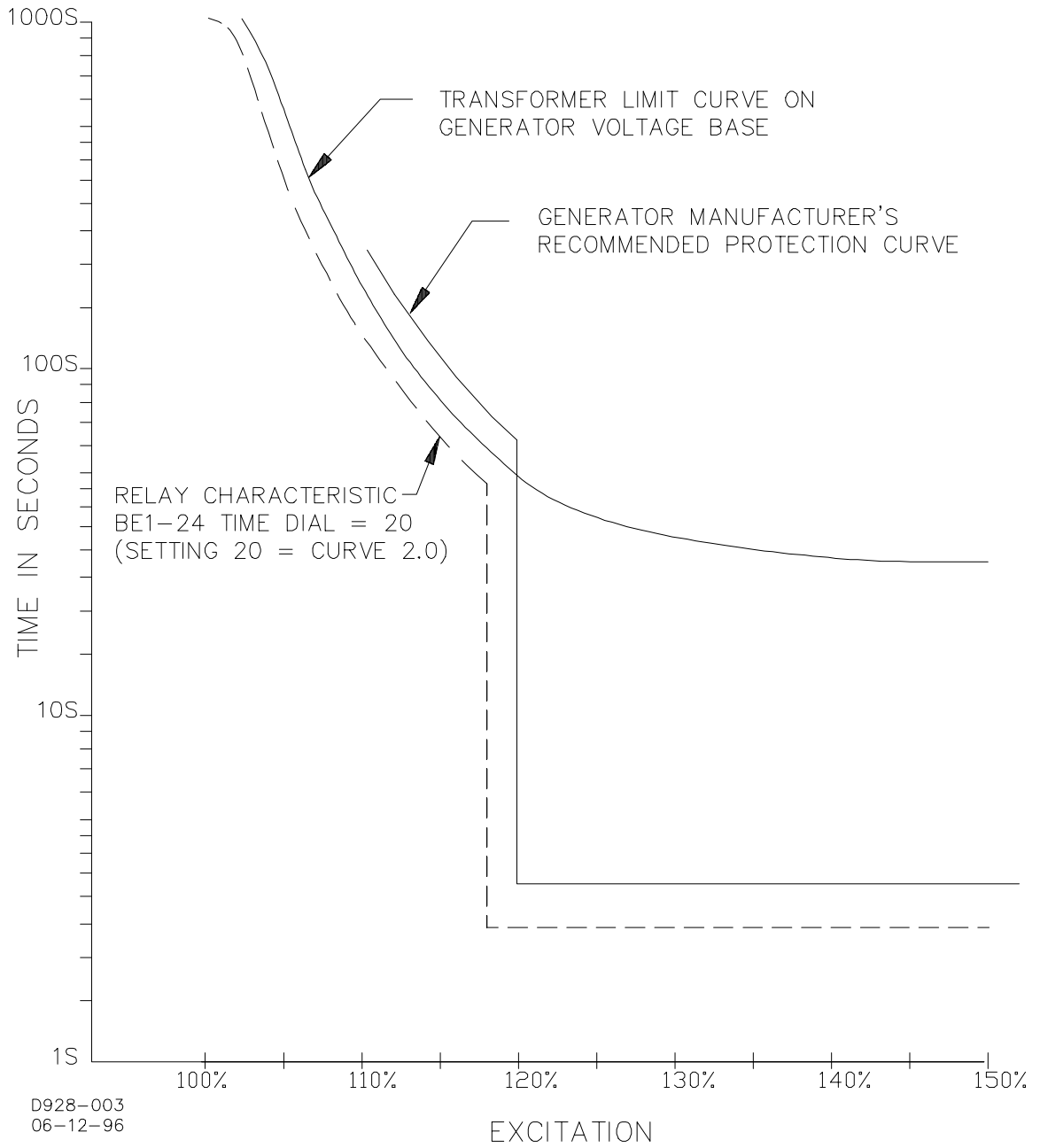

Figure 1-2. Protection Characteristics of the BE1-24

MODEL AND STYLE NUMBER

Electrical characteristics and operational features included in a specific relay are defined by a combination of letters and numbers which constitute the relay style number. The model number, BE1-24, designates the relay as a Basler Electric Class 100 Volts Per Hertz Overexcitation Relay. The style number together with the model number describe the features and options in a particular relay and appear on the front panel, drawout cradle, and inside the case assembly.

Sample Style Number

Figure 1-3 illustrates how a style number determines and describes the relay features. For example, if the style number were A1H-F1J-D1S2F, the relay would have the following features.

- A** - Single-phase voltage sensing
- 1** - Sensing input range of 1.00 to 3.99 V/Hz
- H** - Alarm output NC, trip output NO
- F1** - Inverse square timing
- J** - 125 Vdc power supply
- D** - All targets current operated
- 1** - Instantaneous trip function included
- S** - Push-to-energize-output pushbuttons
- 2** - Normally open auxiliary output contact
- F** - Semi-flush mounting

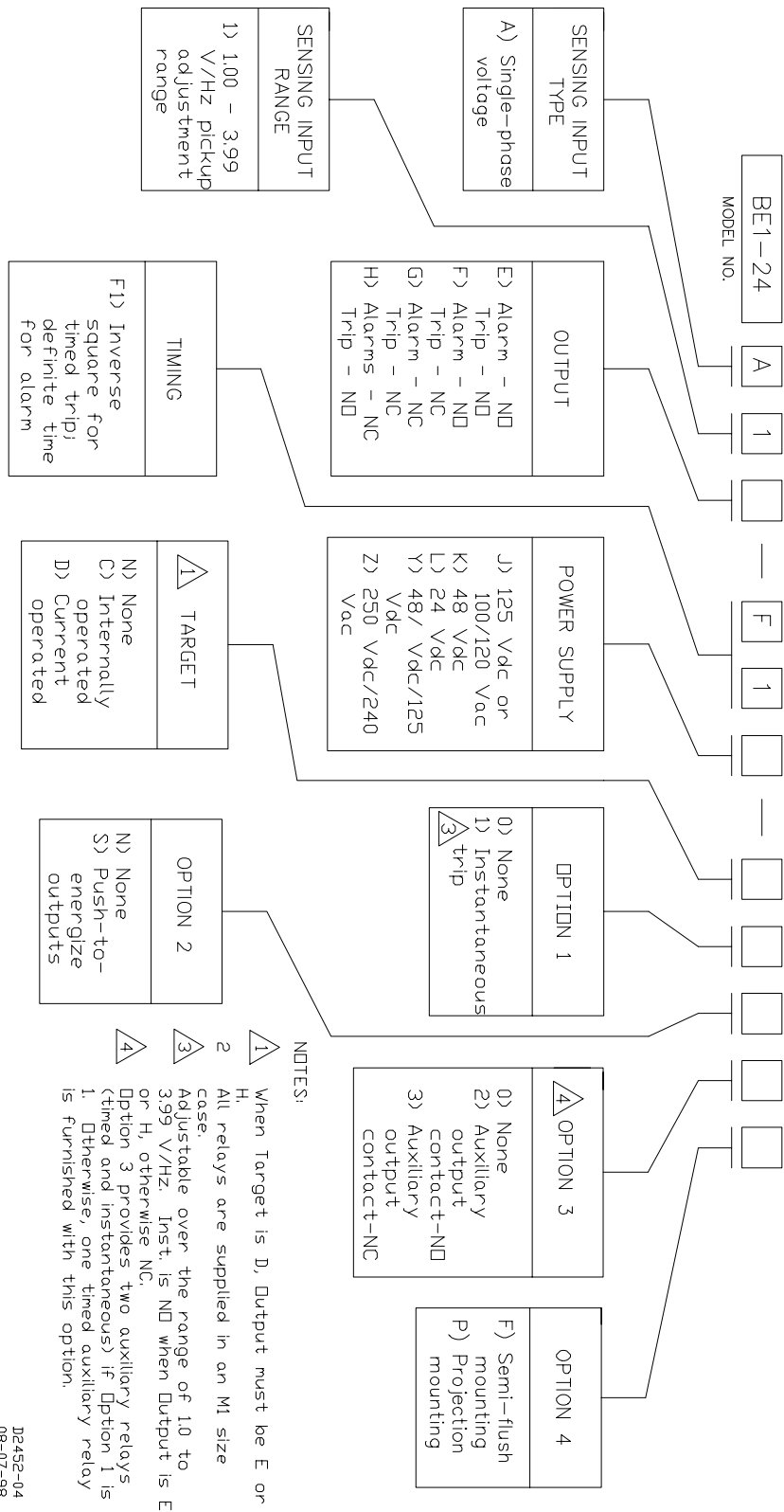

Figure 1-3. Style Number Identification Chart

SPECIFICATIONS

Voltage Sensing

The sensing input transformer has a voltage measuring range of 10 to 360 Vac with a typical frequency measuring range of 3 to 72 hertz. Maximum sensing burden is 3.5 VA. The sensing circuits have an absolute maximum rating of 5 volts/hertz to enable the relay to perform correctly for all system operating conditions.

Power Supply

Power for the internal circuitry may be derived from ac or dc external power sources. Power supply voltages, ranges, and burden are provided in Table 1-1.

Table 1-1. Power Supply Types And Specifications

Type	Nominal Input Voltage	Input Voltage Range	Burden at Nominal
K (Mid Range)	48 Vdc	24 to 150 Vdc	4.0 W
J (Mid Range)	125 Vdc 120 Vac	24 to 150 Vdc 90 to 132 Vac	4.0 W 10.0 VA
L (Low Range)	24 Vdc	12 † to 32 Vdc	4.0 W
Y (Mid Range)	48 Vdc 125 Vdc	24 to 150 Vdc 24 to 150 Vdc	4.0 W 4.0 W
Z (High Range)	250 Vdc 240 Vac	62 to 280 Vdc 90 to 270 Vac	5.0 W 12.0 VA

† Type L power supply initially requires 14 Vdc to begin operating. Once operating, the voltage may be reduced to 12 Vdc and operation will continue.

Outputs

Output contacts are rated as follows:

Resistive

120/240 Vac

Make 30 amperes for 0.2 seconds, carry 7 amperes continuously, and break 7 amperes.

125/250 Vdc

Make 30 amperes for 0.2 seconds, carry 7 amperes continuously, and break 0.3 amperes.

Inductive

120/240 Vac,
125/250 Vdc

Make 30 amperes for 0.2 seconds, carry 7 amperes continuously, and break 0.3 ampere. (L/R = 0.04).

Pickup Adjustment Ranges

(Timed Trip, Alarm, and optional Instantaneous Trip)

Adjustable from 1.00 to 3.99 in 0.01 V/Hz increments. (Any setting above 3.99 V/Hz or below 1.00 V/Hz is limited to 3.99 and 1.00 V/Hz respectively.)

Pickup Accuracy

Pickup accuracy is dependent upon sensed frequency as shown in Table 1-2.

Table 1-2. Pickup Accuracy and Frequency

Sensed Frequency	Accuracy at 25° C	Temperature Stability from a Ref. Measurement at 25° C
40-72 hertz	± 1.0 hertz	± 1.5%
20-40 hertz	± 2.0 hertz	± 3.0%
3-20 hertz	± 8.0 hertz	± 12.0%

Timing Ranges

Inverse Square

(Timed Trip)

Adjustable from 0.1 to 10 in 0.1 increments to select the individual characteristic curve which best matches the protected equipment's damage curve. Minimum time delay is 0.25 seconds and maximum time delay 1000 seconds. A setting of 0.0 is equivalent to a setting of 10.0. See Figure 1-4 or Figure 1-5 for characteristic curves.

Reset Time

(Available for the Timed Trip function only.) Adjustable in seconds per percent of full scale trip time from 0.1 to 9.9 in 0.1 second increments. Note that this means entering a reset rate rather than a reset time.

A setting of 0.0 enables instantaneous reset time.

Definite Time

(Alarm)

Adjustable from 0.1 to 9.9 seconds in 0.1 second increments. A setting of 0.0 enables the Alarm output to be instantaneous.

Instantaneous Trip

(Optional)

132 milliseconds at 60 Hz.

Timing Accuracies

Inverse square and definite time accuracies are as follows:

Inverse Square

(Timed Trip)

Follows the curve shown in Figure 1-4 to an accuracy given in the table below for any combination of TIME DIAL and TIME TRIP PICKUP settings: repeatable within ±5%.

<u>V/Hz</u>	<u>M</u>	<u>Accuracy</u>
V/Hz > 1.50	M > 1.1	±10%
V/Hz < 1.50	1.1 < M < 1.2	±15%
V/Hz < 1.50	M > 1.2	±10%

Where M = multiples of pickup setting.

Definite Time

(Alarm)

Accurate to within ± one-half of the least-significant-digit time plus 25 milliseconds or 1.0% (whichever is greater).

Targets

Magnetically latching, manually reset target indicators are optionally available to indicate that a trip output contact has closed. Either internally operated or current operated targets may be selected. Current operated targets require a minimum of 0.2 A in the output trip circuit to actuate, and trip current must not exceed 30 A for 1 second, 7 A for 2 minutes, and 3 A continuous. Current operated targets only if the relay has normally open (NO) output contacts.

Push-To-Energize-Output Pushbuttons	Accessible with a thin non-conducting rod through the front panel, push-to-energize pushbuttons are available to energize each output relay for testing the external control/protective system wiring.
Shock	In standard tests, the relay has withstood 15 g in each of three mutually perpendicular axes without structural damage or degradation of performance.
Vibration	In standard tests, the relay has withstood 2 g in each of three mutually perpendicular axes swept over the range of 10 to 500 hertz for a total of six sweeps, 15 minutes each sweep, without structural damage or degradation of performance.
Isolation	In accordance with IEC 255-5 and ANSI/IEEE C37.90, one minute dielectric (high potential) tests as follows: All circuits to ground: 2121 Vdc Input to output circuits: 1500 Vac or 2121 Vdc
Surge Withstand Capability	Qualified to ANSI/IEEE C37.90.1-1989, <i>Standard Surge Withstand Capability (SWC) Tests for Protective Relays and Relay System</i> , and IEC 255-5, <i>Impulse Test and Dielectric Test</i> .
Impulse Test	Qualified to IEC 255-5.
Radio Frequency Interference (RFI)	Maintains proper operation when tested in accordance with IEEE C37.90.2-1987 <i>Trial-Use Standard Withstand Capability of Relay Systems to Radiated Electromagnetic Interference from Transceivers</i> .
UL Recognition	UL Recognition per Standard 508, UL File No. E97033. Note: Output contacts are not UL Recognized for voltages greater than 250 volts.
Temperature	
<u>Operating</u>	-40°C (-40°F) to +70°C (+158°F)
<u>Storage</u>	-65°C (-85°F) to +100°C (+212°F)
Weight	17.3 pounds maximum
Case Size	All relays are supplied in a M1 double-ended case.

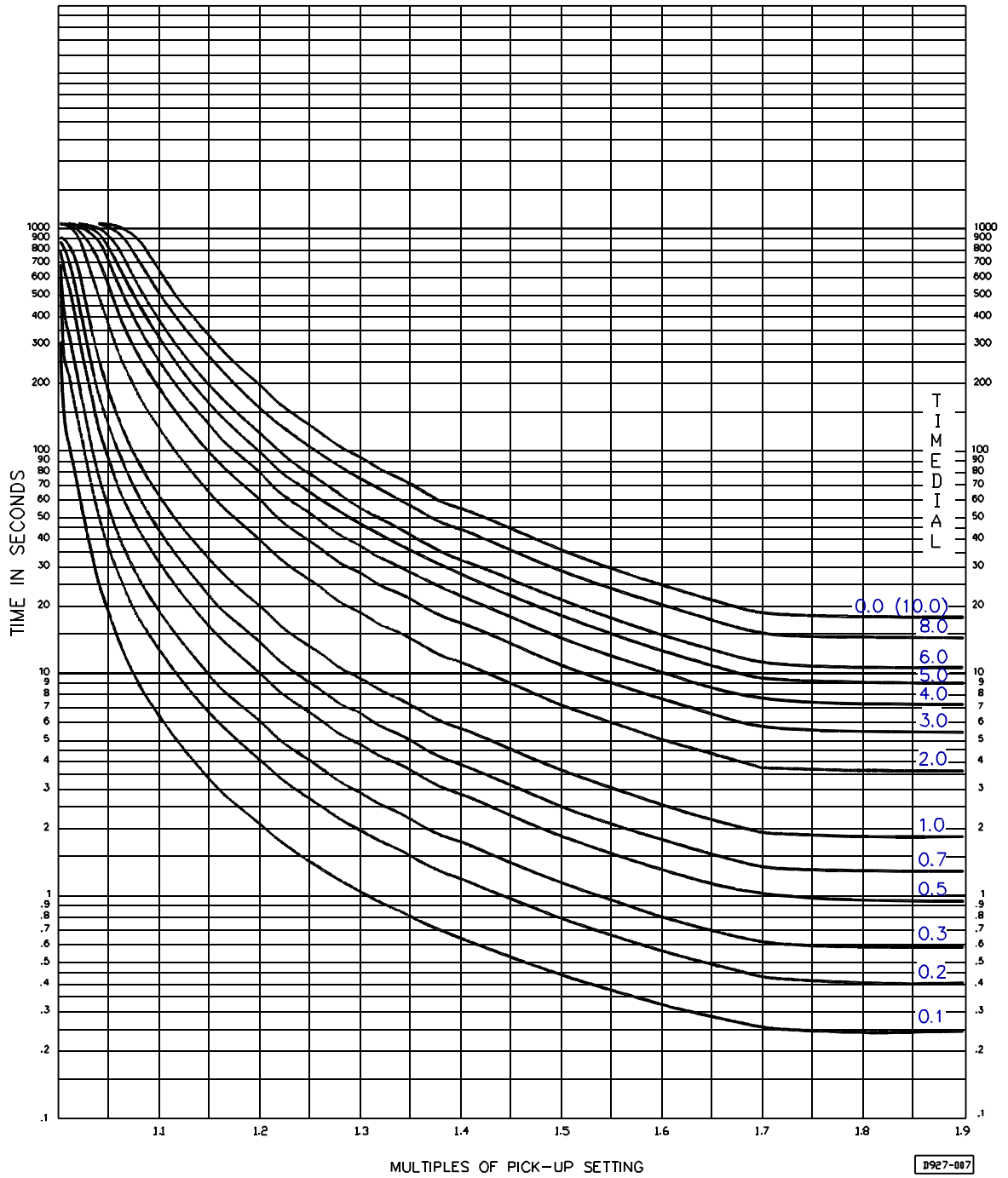
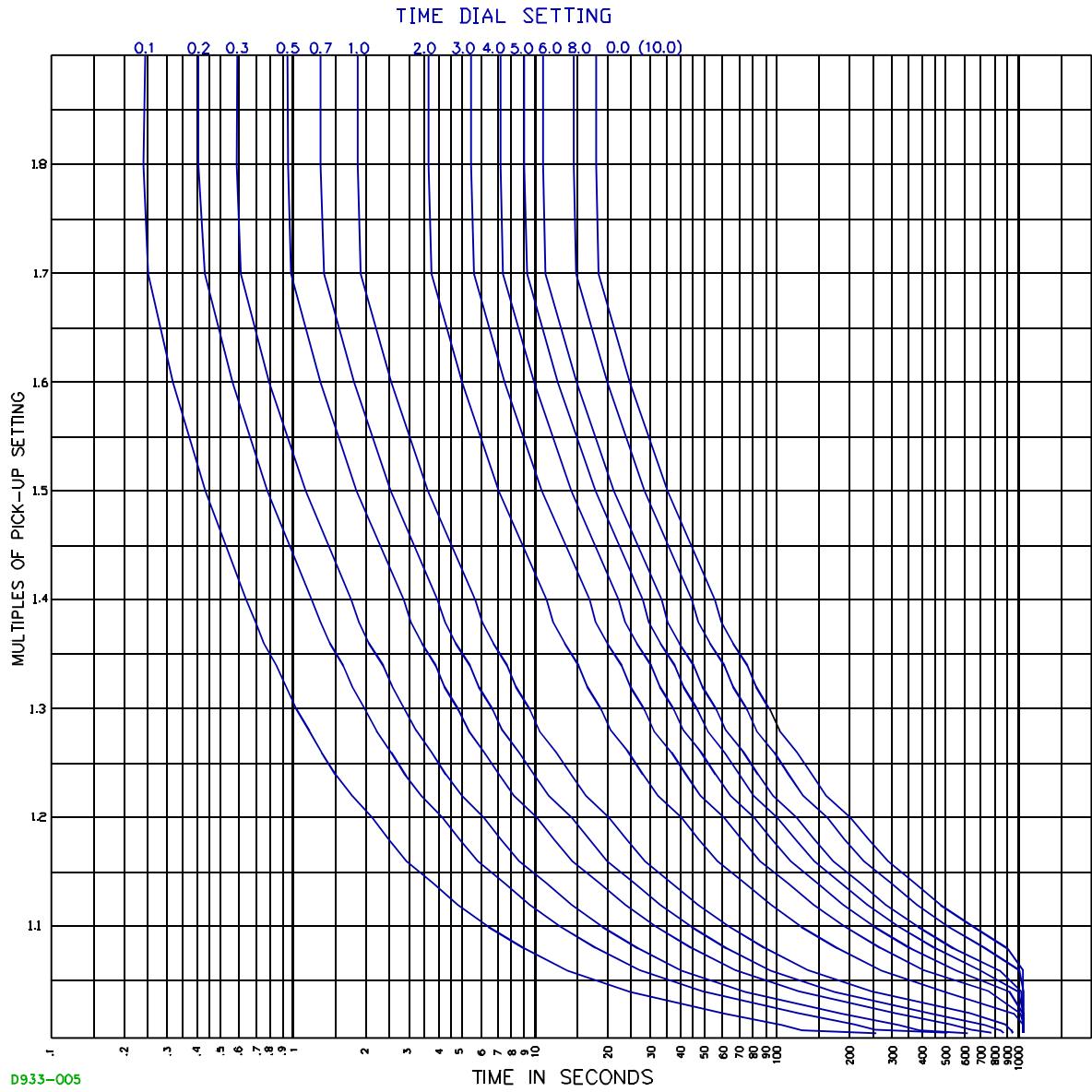

Figure 1-4. Inverse Square Characteristic Curves



D933-005

Figure 1-5. Inverse Square Characteristic Curves (Multiples of Pickup vs. Time)

SECTION 2 • HUMAN-MACHINE INTERFACE

CONTROLS AND INDICATORS

Table 2-1 lists and briefly describes the BE1-24 controls and indicators. Reference the callouts to Figure 2-1.

Table 2-1. BE1-24 Controls and Indicators

Locator	Control or Indicator	Function
A	INST. PICKUP (Optional)	Thumbwheel adjustment establishes the pickup point for the instantaneous output. Adjustable from 1.0 to 3.99 V/Hz in 0.01 V/Hz increments.
B	TIME TRIP PICKUP	Thumbwheel adjustment establishes the pickup point for the time trip output. Adjustable from 1.0 to 3.99 V/Hz in 0.01 V/Hz increments.
C	TIME DIAL	Thumbwheel adjustment to select individual inverse square characteristic curve. Adjustable from 0.1 to 10.0 in 0.1 increments. To select 10.0, set 0.0 (there is no tens digit thumbwheel) on the TIME DIAL thumbwheels.
D	RESET	Thumbwheel adjustment establishes the linear rate of reset per percent of full-scale trip time to model the protected equipment's cooling rate. Adjustable from 0.1 to 9.9 seconds in 0.1 second increments. A setting of 0.0 enables the reset time to be instantaneous.
E	ALARM PICKUP	Thumbwheel adjustment establishes the pickup point for the alarm output. Adjustable from 1.0 to 3.99 V/Hz in 0.01 V/Hz increments.
F	ALARM TIME DELAY	Thumbwheel adjustment establishes the definite time delay for the alarm output. Adjustable from 0.1 to 9.9 seconds in 0.1 second increments. A setting of 0.0 enables the alarm output to be instantaneous.
G	ALARM PICKUP Indicator	When ON, red LED indicates that the alarm pickup setting has been exceeded and that the unit is timing.
H	POWER Indicator	When ON, red LED indicates that the power supply is providing nominal ± 12 Vdc to internal operating circuitry.
I	Target Reset Lever	Mechanical lever used to reset magnetically latched target indicators.
J	Trip Target Indicators	Magnetically latched, manually reset target indicators provide visual indication that the respective trip output relay has been energized. Must be manually reset.
K	PUSH-TO-ENERGIZE OUTPUT	Pushbuttons provide manual actuation of the output contacts by insertion of a 1/8 inch thick non-conducting rod (not supplied) through the access holes in the front panel.
L	Timing Status Display (TSD)	A series of 10 LED's used to indicate the accumulation of time towards trip or reset. Each LED represents approximately 10% of the total time accumulated. See Section 3 for complete functional description.
M	TIME TRIP PICKUP Indicator	When ON, red LED indicates that the time trip pickup setting has been exceeded and that the unit is timing.

D1184-02
8-17-92

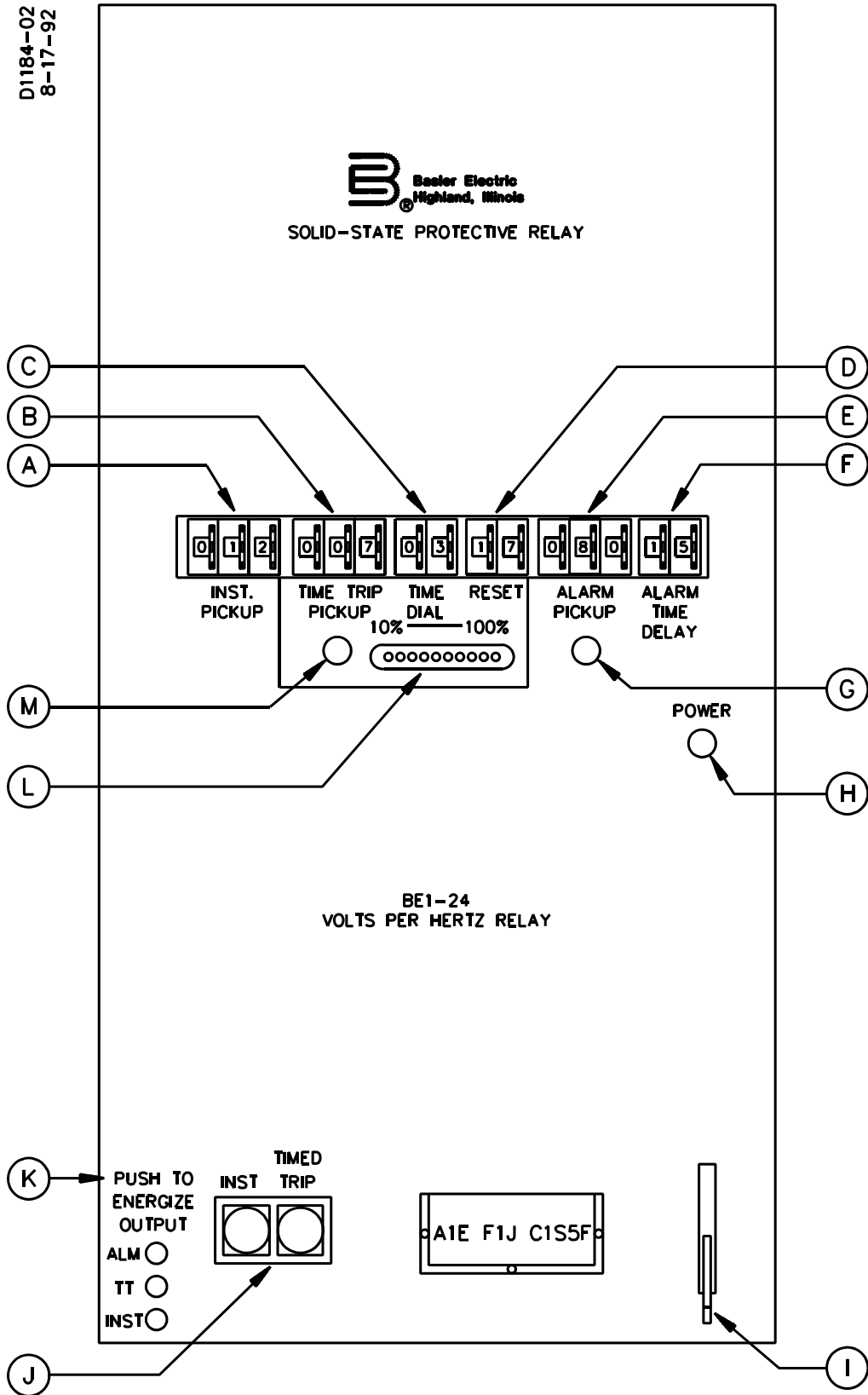

Figure 2-1. Location of Controls and Indicators

SECTION 3 • FUNCTIONAL DESCRIPTION

GENERAL

BE1-24 Volts Per Hertz Overexcitation Relays are microprocessor based to match application requirements, achieve accuracy of measurements and repeatability.

FUNCTIONAL DESCRIPTION

The following descriptions are referenced to the functional block diagram, Figure 3-1.

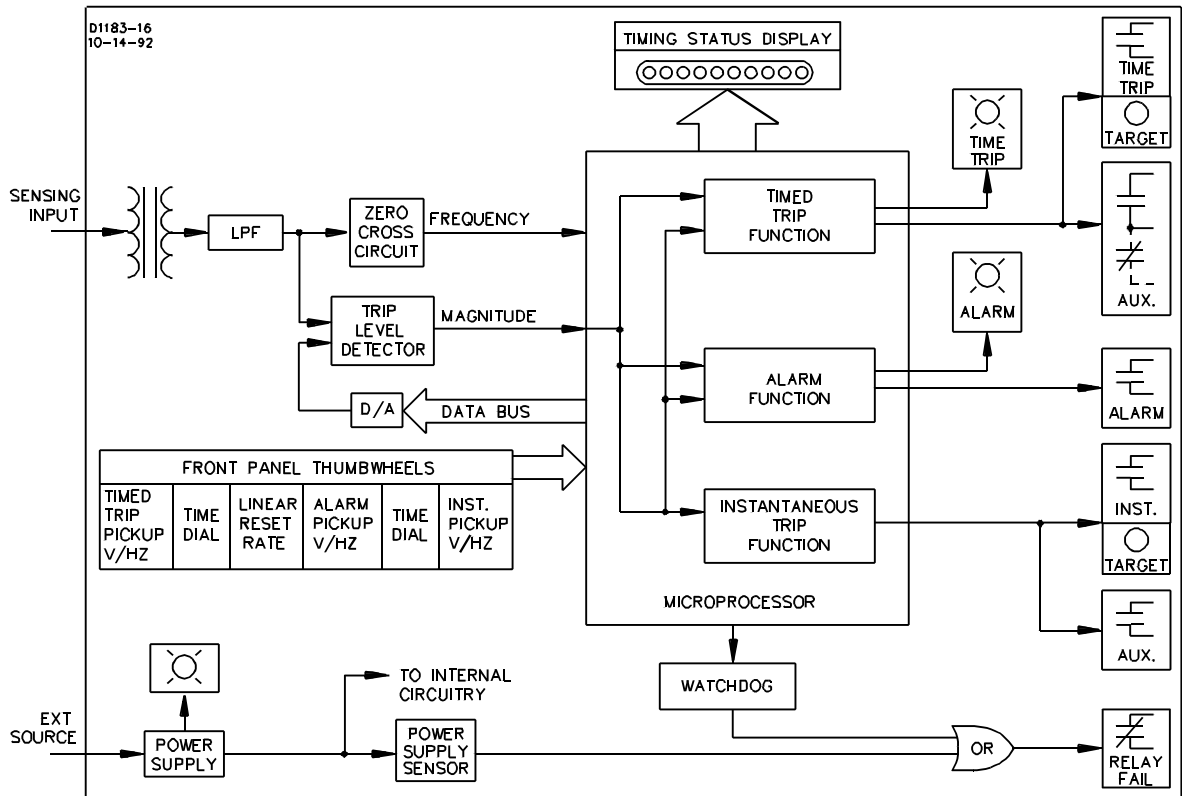

Figure 3-1. Functional Block Diagram

Thumbwheel Switches

Thumbwheel switches on the front panel of the relay are easily adjusted to define the relay operating characteristics. These thumbwheel settings define the volts per hertz pickup levels for the time delayed trip, the alarm, and the (optional) instantaneous trip functions. Thumbwheel settings also define the time delay for tripping and reset.

Input Sensing

BE1-24 relays have input sensing transformers that sense a single phase of system voltage. These transformers have a measuring range of 10 to 360 volts at frequencies from 3 to 72 hertz. The rating of five volts per hertz identifies the absolute maximum voltage at a given frequency at which the relay is able to perform correctly for all system operating conditions.

Third Harmonic Rejection Filter

The volts per hertz signal from the secondary of the sensing input transformer is passed through the low pass, third harmonic (180 hertz) filter. This filter attenuates by 21 db, the peak distorting effect that the third harmonic places on the 60 hertz fundamental. The microprocessor uses peak detection to calculate magnitude (relative to pickup setting) for trip. In this way, greater sensitivity and more precise application can be realized.

Microprocessor

The microprocessor determines if the actual volts per hertz condition exceeds the established limits of the protected system by first measuring the actual frequency, and then determining the maximum allowable voltage for each of the three functional settings which may be included in the relay. The microprocessor operation is synchronized with the zero crossings of the input waveform. All timing functions within the relay are incorporated within the microprocessor and the microprocessor program.

The microprocessor starts the sequence by measuring system frequency during the first negative half cycle. During the second positive half cycle, it calculates the maximum permissible voltage level for the time delayed trip setting. It then subsequently calculates the corresponding values for the (optional) instantaneous trip setting and for the alarm setting on the successive positive cycles. (See Figure 3-2.) At the proper time this digital information is supplied to an external digital-to-analog converter in preparation for magnitude comparison.

Pickup for all three functions is individually adjustable over the range of 1.00 to 3.99 in 0.01 volts per hertz increments. Pickup accuracy is dependent upon frequency as indicated below.

<u>Frequency Range</u>	<u>Accuracy at 25°C</u>
40 - 72 Hz	±1 Hz
20 - 40 Hz	±2 Hz
3 - 20 Hz	±8 Hz

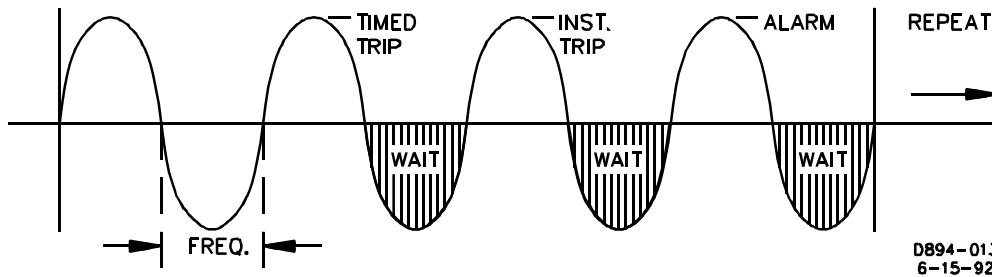

Figure 3-2. Calculation Sequence

Trip Level Detector

An analog comparator sequentially monitors the sensed input waveform to determine if system conditions are within allowable operating limits. The microprocessor sequentially outputs the allowable levels for each function to the digital-to-analog converter. The analog output is then compared to the actual system voltage level. If the monitored voltage exceeds the limit, the appropriate function within the microprocessor is initiated.

Digital-To-Analog Converter

The representative binary-coded-decimal (BCD) number derived from the first cycle frequency calculation is combined with the BCD number from the respective front panel thumbwheel. The microprocessor then calculates the value for trip, based on these two inputs, and passed the data to the digital-to-analog converter (DAC). The DAC converts the digital signal from the microprocessor to an analog value which is used as the reference for trip by the magnitude comparator. When the monitored waveform is at a level that is above the previously established reference value, the appropriate action is initiated (i.e., instantaneous output energized, or TIME TRIP or ALARM LED lit and timing initiated).

OUTPUT FUNCTIONS

BE1-24 Volts Per Hertz Overexcitation Relays have two standard and one optional independent output functions. Standard independent output functions are the inverse square timed trip and the definite time alarm. The optional independent output function is the instantaneous trip function.

Inverse Square Timing

Inverse square timing is used for the timed trip function. This closely approximates the heating characteristic of the protected equipment as overexcitation increases. A linear reset characteristic provides for the decreasing (cooling) condition. The timed trip desired for the overexcitation condition is defined by front panel thumbwheel switches (adjustable from 0.1 to 10.0 in increments of 0.1). The minimum time delay (TIME DIAL setting 0.1) is fixed at 0.25 seconds, and the maximum time delay is approximately 1000 seconds. Refer to Figure 1-4 or Figure 1-5. Because there is no TIME DIAL tens digit, a setting of 0.0 is equivalent to a TIME DIAL setting of 10.0 and is the maximum time delay.

The Integrating Trip Timer, within the microprocessor, provides the inverse square timing function and the reset function. Whenever the timed trip pickup setting is exceeded, the integrating trip timer begins ramping up in accordance with the selected inverse square curve until a trip output is produced. But if the volts per hertz condition falls below the pickup setting, the integrating trip timer will ramp down towards reset at a linear rate that is based on the front panel RESET time dial.

Reset time may be expressed by:

$$RST = THS \times \frac{ET}{FST} \times 100$$

where:

RST	=	Reset time (in seconds)
THS	=	Thumbwheel setting
ET	=	Elapsed time (time accumulated towards trip)
FST	=	Full-scale trip time (from selected curve of Figure 1-4 or Figure 1-5)

Reset rate is individually adjustable, using the front panel thumbwheel. Settings are from 0.1 to 9.9 seconds per percent of full-scale trip time in 0.1 second increments. A setting of 0.0 enables reset to be instantaneous.

For example, assume a time dial setting of 25 (curve 2.5) and a multiple of pickup setting of 1.2. The total time to trip will be 50 seconds. If this exists for 30 seconds before being corrected (60% elapsed time), what would the total reset time be for a reset setting of 7.5. Based on the equation for reset time, the equation would look like this:

$$RST = 7.5 \times \frac{30}{50} \times 100 = 450$$

If the overexcitation condition returns prior to total reset (i.e. less than 450 seconds), timing resumes from that point at the inverse square rate. If this condition recurs after 225 seconds, the time to trip for the second event would be 35 seconds. Figure 3-3 illustrates the inverse time delay and reset time.

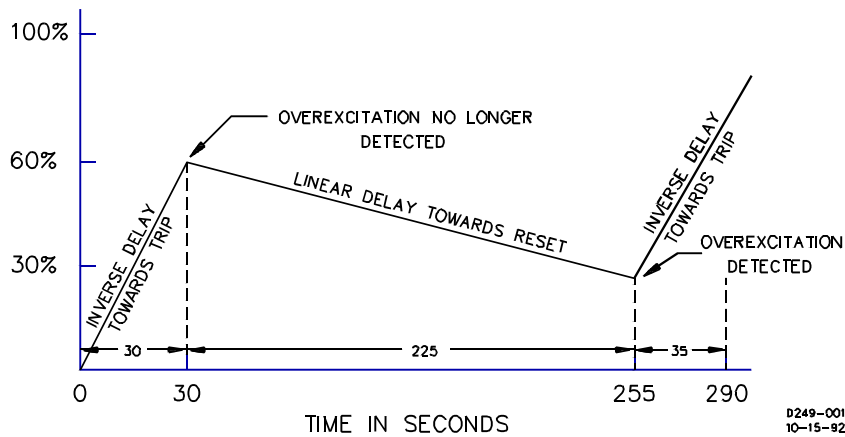

Figure 3-3. Inverse Time Delay and Reset Time

After tripping occurs, the relay resets at the defined linear rate only after the overexcitation condition has been corrected (when voltage falls below the volts per hertz pickup point). This is provided that the tripping action does not remove the sensing potential totally. If the sensing potential is removed, the timing function is reset.

Definite Time Alarm

Definite time delay for the alarm function is adjustable, using a front panel thumbwheel with settings from 0.1 to 9.9 seconds in 0.1 second increments. A setting of 0.0 enables the alarm output to be instantaneous. The alarm time delay is performed by the microprocessor. When the pre-selected alarm pickup level has been exceeded, timing is initiated. As long as volts per hertz remains above pickup, timing will continue for the selected duration. At that time, the alarm output relay energizes.

Instantaneous Trip Output

Instantaneous trip output is optional. When this option has been selected, the relay will respond in less than eight cycles for a volts per hertz magnitude that is 1.5 times or greater than the pre-selected pickup setting.

OUTPUTS

Output relays are provided for the alarm and timed trip functions. Contact configuration is either normally open (NO) or NC as determined by the style chart. If the instantaneous trip function has been selected, the output relay contact configuration will be the same as the selected contact configuration for timed trip. The relay fail output contact is NC for all relay styles. Auxiliary output relays are optionally available for the timed trip and instantaneous trip functions only and may have either NO or NC contacts.

TIMING STATUS DISPLAY (TSD)

Associated with the trip integrating timer is a timing status display consisting of a series of 10 LEDs (Figure 3-4).

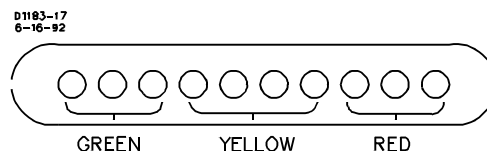

Figure 3-4. Time Progression Display

This display indicates the status of the integrating timer. As time accumulates toward trip, these LEDs are illuminated. Each LED represents 10 percent of the total required for tripping.

As the timed trip pickup level is exceeded, the LEDs begin illuminating in ascending order from left to right (green to red). When all LEDs are illuminated, the timed trip output relay is energized.

Similarly (but in reverse order), as the volts per hertz condition falls below pickup, the LEDs extinguish in a descending order (red to green). The last step in the descending direction is reset. At that time, the timed trip output relay is de-energized.

WATCHDOG CIRCUITRY

The watchdog circuitry continuously monitors the operation of the microprocessor. Should the microprocessor malfunction or experience improper sequencing, the watchdog disables the microprocessor and the normally closed (NC) relay fail output contacts close. At this time, further operation of the relay is inhibited. The relay must be powered down, then powered back up, to re-initiate the microprocessor.

RELAY FAIL FUNCTION

A normally closed output contact is provided to indicate failure of the power supply or improper operation of the microprocessor. Under normal operating conditions, and with power applied to the relay, this output relay is energized and its contacts are open. If the power supply ceases to provide proper voltages to the internal circuitry, or the watchdog circuitry detects a malfunction of the microprocessor, these contacts close.

TARGETS

Magnetically latching, manually reset target indicators are optionally available to indicate that a timed trip output or an instantaneous trip output (if selected) has closed. For details refer to Section 1.

BUILT-IN-TEST

Built-in-test (BIT) is a feature (not shown on block diagram) that provides a quick-test routine that is programmed into the relay. When initiated by the printed circuit mounted slide switch on the logic board, the relay performs a pre-programmed sequence that verifies all indicators and outputs. Each event of the sequence occurs at one-second intervals. BIT provides a quick hardware check prior to installation or troubleshooting.

PUSH-TO-ENERGIZE-OUTPUT PUSHBUTTONS

Push-To-Energize-Output pushbuttons are optionally available to energize each output relay for testing the external control/protective system wiring. The pushbuttons are actuated through front panel access holes by means of a thin non-conducting rod having a maximum diameter of 0.125 inches.

POWER SUPPLY

Basler Electric enhanced the power supply design for unit case relays. This new design created three, wide range power supplies that replace the five previous power supplies. Style number identifiers for these power supplies have not been changed so that customers may order the same style numbers that they ordered previously. The first newly designed power supplies were installed in unit case relays with EIA date codes 9638 (third week of September 1996). Relays with a serial number that consists of one alpha character followed by eight numerical characters also have the new wide range power supplies. A benefit of this new design increases the power supply operating ranges such that the 48/125 volt selector is no longer necessary. Specific voltage ranges for the three new power supplies and a cross reference to the style number identifiers are shown in the following table.

Table 3-1. Wide Range Power Supply Voltage Ranges

Power Supply	Style Chart Identifier	Nominal Voltage	Voltage Range
Low Range	L	24 Vdc	12† to 32 Vdc
Mid Range	J, K, Y	48, 125 Vdc, 120 Vac	24 to 150 Vdc 90 to 132 Vac
High Range	Z	125, 250 Vdc, 120, 240 Vac	62 to 280 Vdc 90 to 270 Vac

† 14 Vdc required to start the power supply.

Relay operating power is developed by the wide range, isolated, low burden, flyback switching, solid state power supply. Nominal ± 12 Vdc is delivered to the relay internal circuitry. Input (source voltage) for the power supply is not polarity sensitive. A red LED turns ON to indicate that the power supply is functioning properly.

SECTION 4 • INSTALLATION

GENERAL

When not shipped as part of a control or switchgear panel, the relays are shipped in sturdy cartons to prevent damage during transit. Immediately upon receipt of a relay, check the model and style number against the requisition and packing list to see that they agree. Visually inspect the relay for damage that may have occurred during shipment. If there is evidence of damage, immediately file a claim with the carrier and notify the Regional Sales Office, or contact the Sales Representative at Basler Electric, Highland, Illinois.

In the event the relay is not to be installed immediately, store the relay in its original shipping carton. When relay is to be placed in service, it is recommended that the operational test procedure (Section 5, *Testing*) be performed prior to installation.

RELAY OPERATING PRECAUTIONS

Before installation or operation of the relay, note the following precautions:

1. A minimum of 0.2 A in the output circuit is required to ensure operation of current operated targets.
2. The relay is a solid-state device. If a wiring insulation test is required, remove the connection plugs and withdraw the cradle from its case.
3. When the connection plugs are removed, the relay is disconnected from the operating circuit and will not provide system protection. Always be sure that external operating (monitored) conditions are stable before removing a relay for inspection, test, or service.
4. Be sure the relay case is hard wired to earth ground using the ground terminal on the rear of the unit. It is recommended to use a separate ground lead to the ground bus for each relay.

DIELECTRIC TEST

In accordance with IEC 255-5 and ANSI/IEEE C37.90, one minute dielectric (high potential) tests as follows:

All circuits to ground: 2121 Vdc
Input to output circuits:
1500 Vac or 2121 Vdc

MOUNTING

Because the relay is of solid state design, it does not have to be mounted vertically. Any convenient mounting angle may be chosen. Relay outline dimensions and panel drilling diagrams are provided in Figures 4-1 through 4-6.

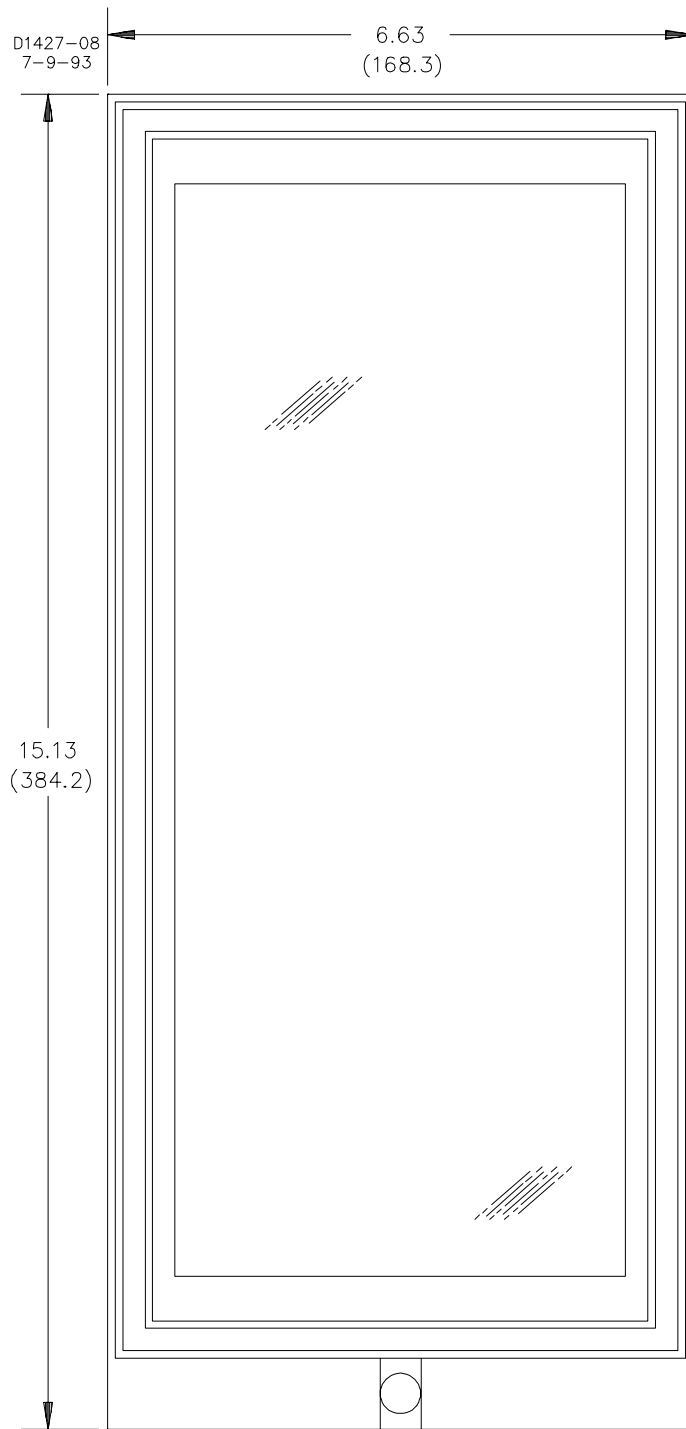

Figure 4-1. M1 Case, Outline Dimensions, Front View

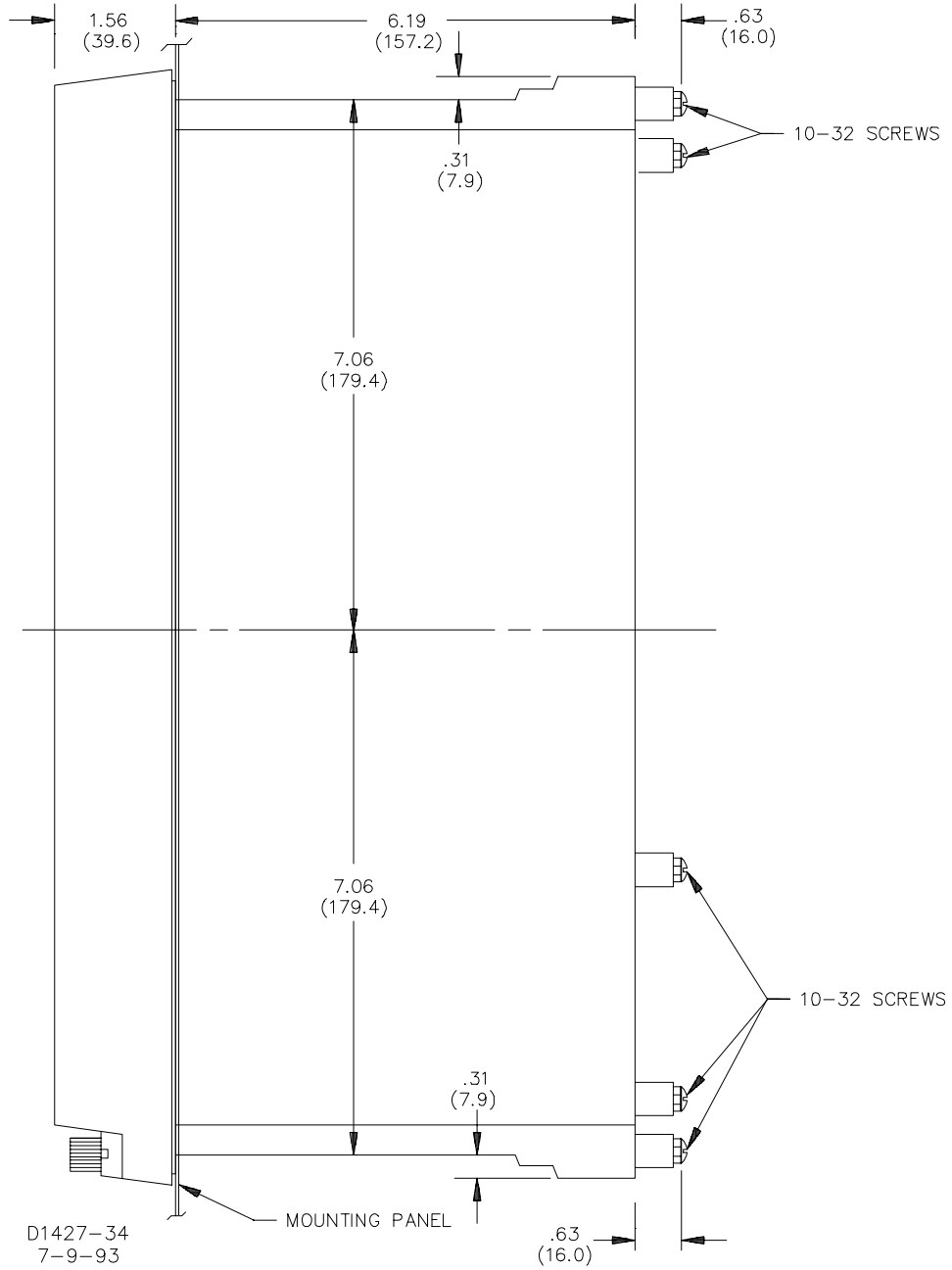

Figure 4-2. M1 Case, Double-Ended, Semi-Flush Mounting, Outline Dimensions, Side View

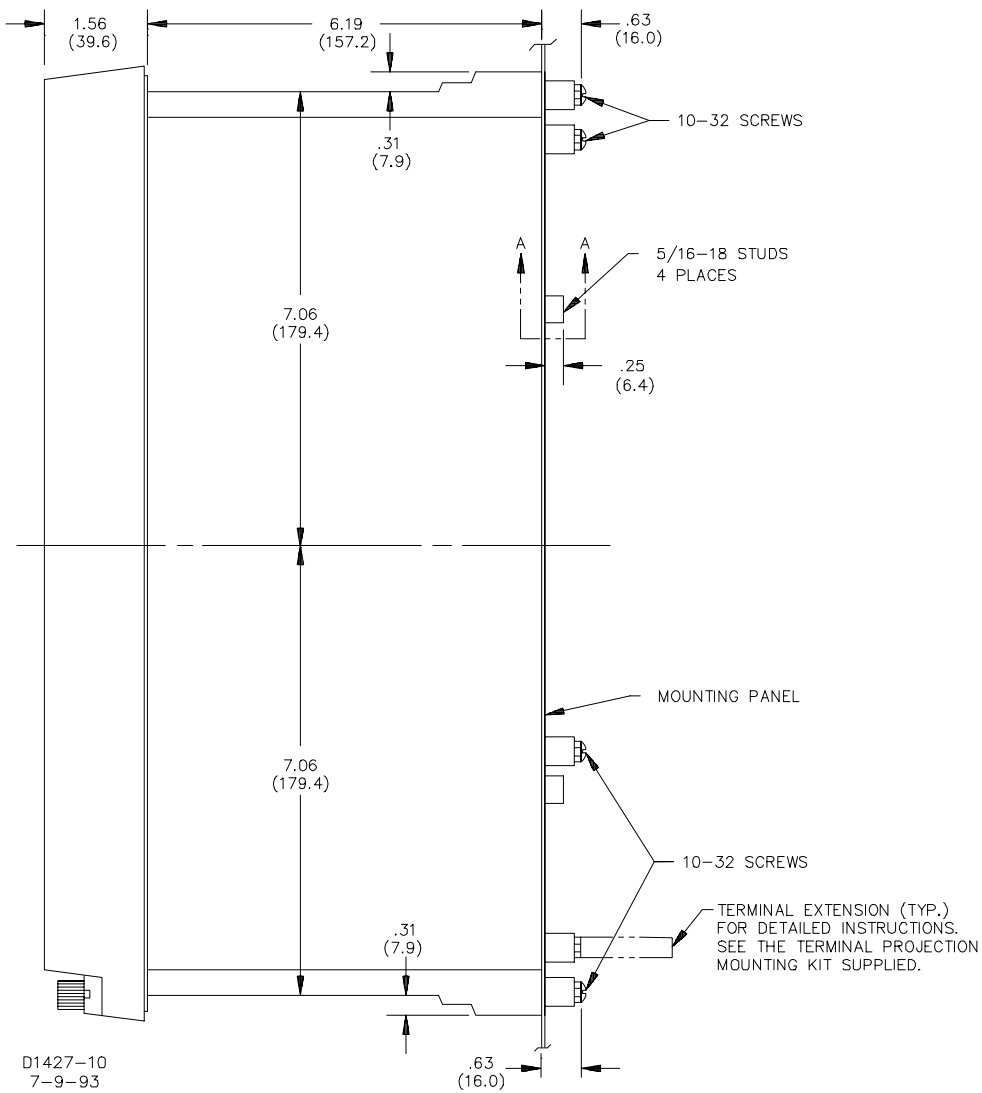

Figure 4-3. M1 Case, Double-Ended, Projection Mounting, Outline Dimensions, Side View

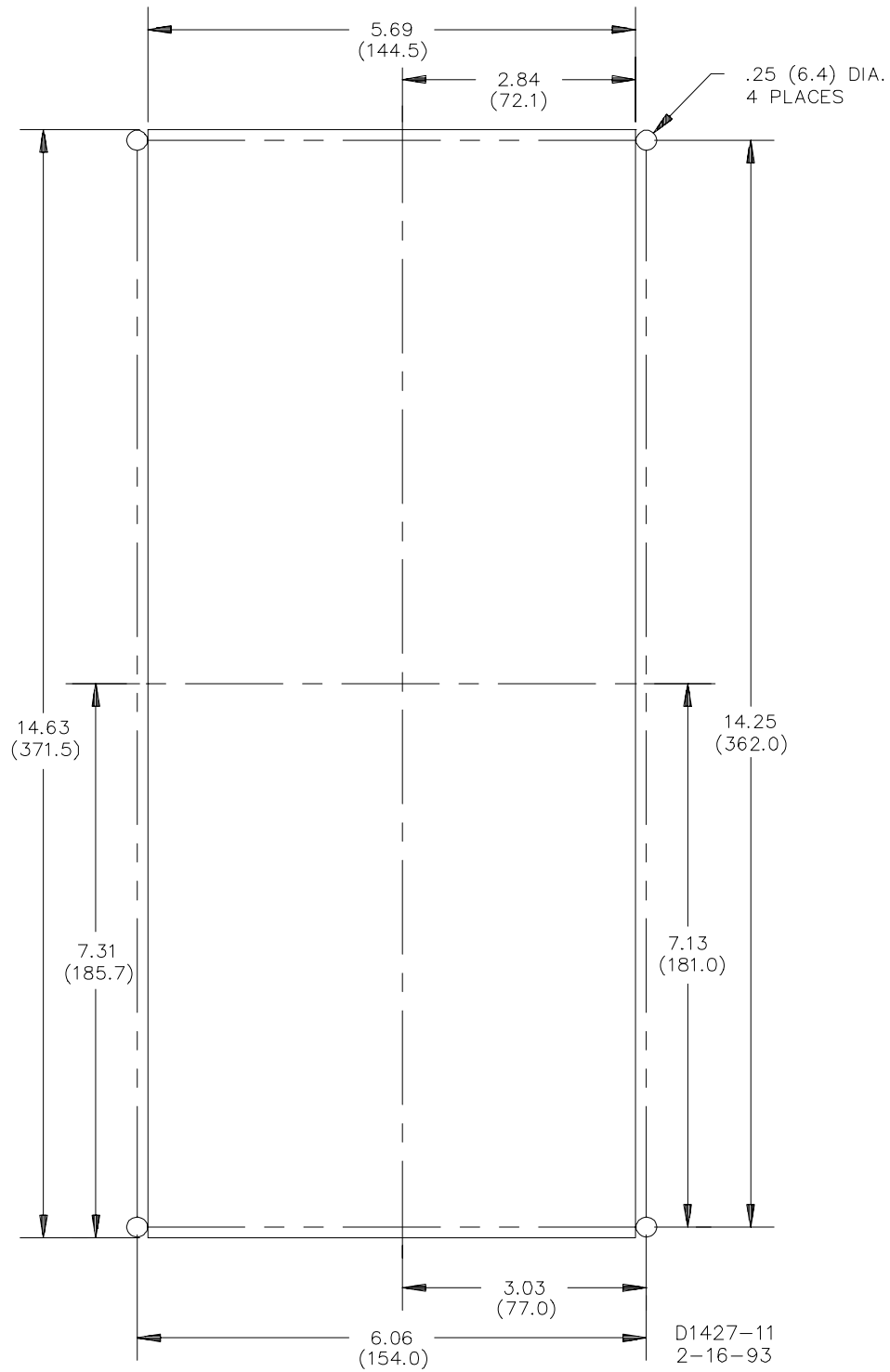

Figure 4-5. M1 Case, Panel Drilling Diagram

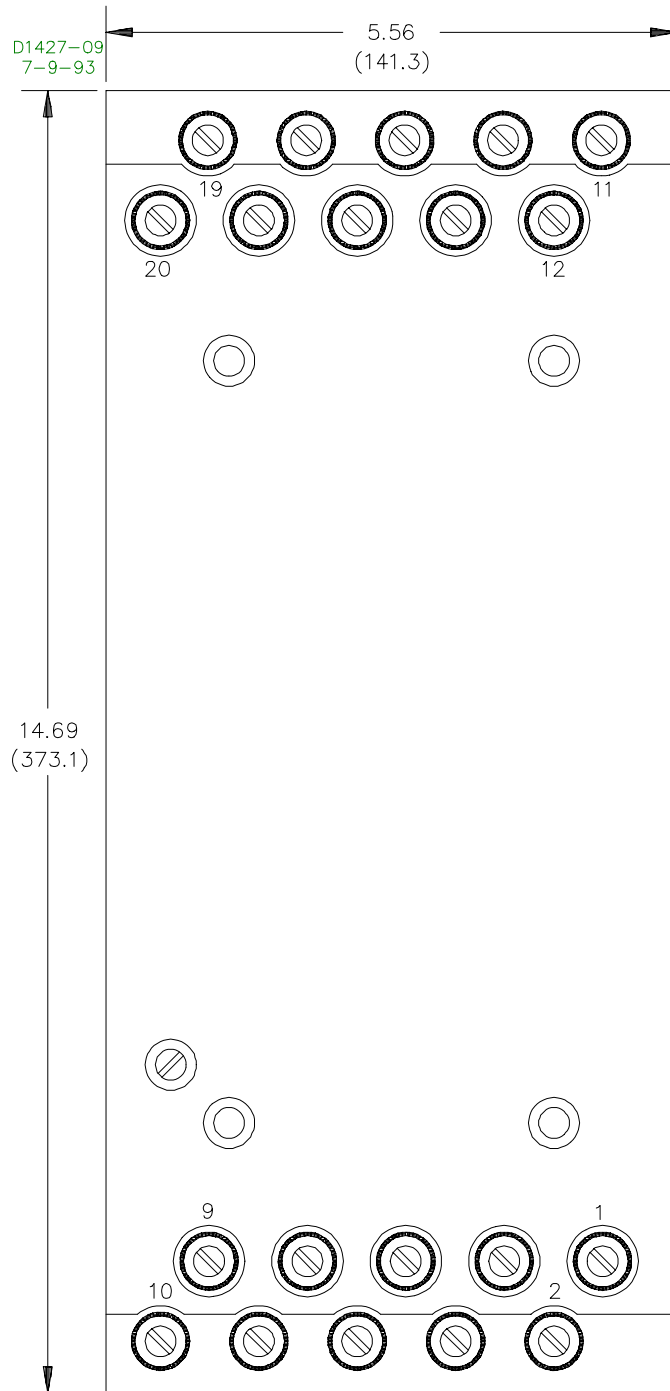

Figure 4-6. M1 Case, Projection Mounting, Outline Dimensions, Rear View

CONNECTIONS

Incorrect wiring may result in damage to the relay. Be sure to check model and style number against the options listed in the Style Number Identification Chart before connecting and energizing a particular relay.

NOTE

Be sure the relay case is hard-wired to earth ground with no smaller than 12 AWG copper wire attached to the ground terminal on the rear of the relay case. When the relay is configured in a system with other protective devices, it is recommended to use a separate lead to the ground bus from each relay.

Connections should be made with minimum wire size of 14 AWG except as noted for the ground wire. Typical internal connections are shown in Figure 4-7. Typical AC sensing connections are shown in Figure 4-8, and a typical control circuit diagram is shown in Figure 4-9.

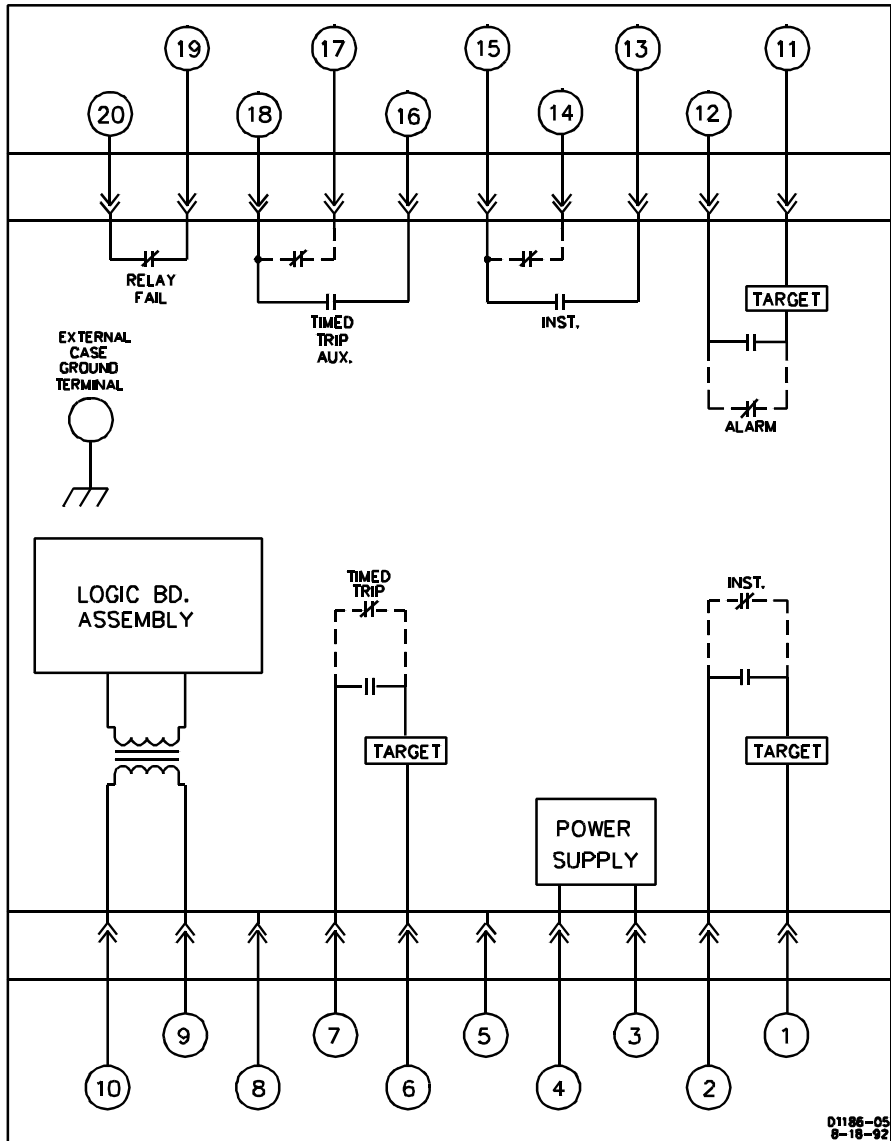

Figure 4-7. Typical Internal Connections

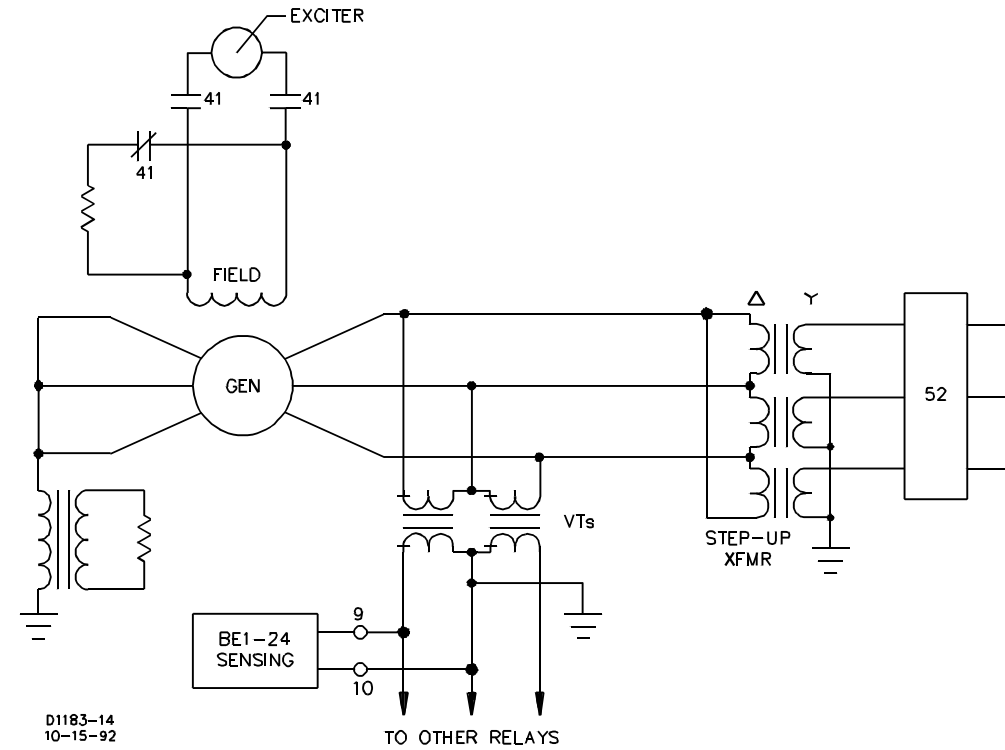
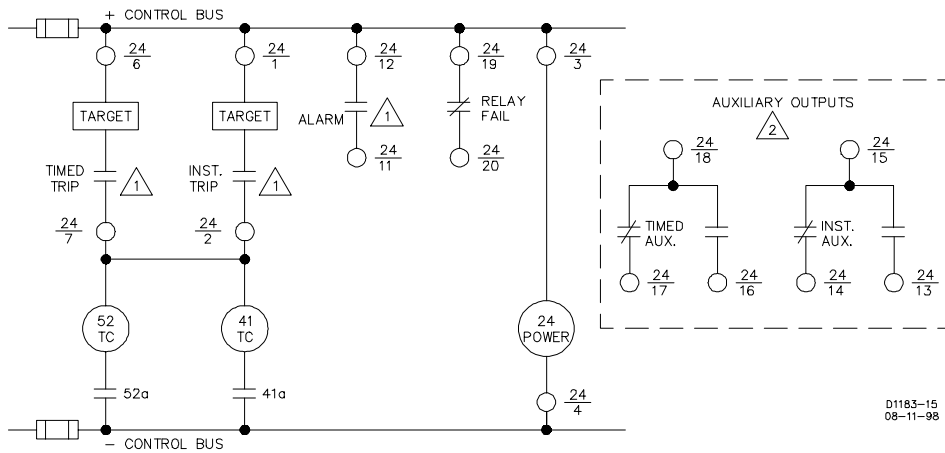

Figure 4-8. Typical AC Sensing Connections



- LEGEND:
- 24 VOLTS PER HERTZ OVEREXCITATION RELAY
 - 52 TC BREAKER TRIP COIL
 - 52a BREAKER AUXILIARY CONTACT
 - 41 TC FIELD CIRCUIT BREAKER TRIP COIL
 - △1 N.O. CONTACT SHOWN; N.C. OPTIONAL
 - △2 OPTION 3 OF THE STYLE CHART DETERMINES NO OR NC

Figure 4-9. Typical Control Circuit Diagram

SECTION 5 • TESTING

GENERAL

In the event the relay is not to be installed immediately, store the relay in its original shipping carton. When the relay is to be placed in service, it is recommended that the operational test procedure in this section be performed prior to installation.

RELAY OPERATING PRECAUTIONS

Before installation or operation of the relay, note the following precautions:

1. A minimum of 0.2 A in the output circuit is required to ensure operation of current operated targets.
2. The relay is a solid-state device. If a wiring insulation test is required, remove the connection plugs and withdraw the cradle from its case.
3. When the connection plugs are removed, the relay is disconnected from the operating circuit and will not provide system protection. Always be sure that external operating (monitored) conditions are stable before removing a relay for inspection, test, or service.
4. Be sure the relay case is hard wired to earth ground using the ground terminal on the rear of the unit. It is recommended to use a separate ground lead to the ground bus for each relay.

BUILT-IN-TEST

The relay incorporates the BIT function as a convenient hardware test. This troubleshooting aid can verify each indicator and output driver circuit for proper operation. To implement the BIT, proceed as follows.

Step 1. With the unit in a power-up condition place switch S1 (on the logic board) to the TEST position.

Step 2. Verify that the relay runs through its programmed sequence of events as follows.

- a.) Timed trip pickup LED turns ON.
- b.) Timing status display turns ON (each LED turns ON in ascending order, green to red).
- c.) Alarm pickup LED turns ON.
- d.) Instantaneous output relay energizes.
- e.) Alarm output relay energizes.
- f.) Timed trip output relay energizes.

If auxiliary output relays have been specified, they will energize simultaneously with the respective main output relays.

OPERATIONAL TEST PROCEDURE

The following procedures verify proper operation and calibration of the relay. Throughout the procedure, various values for M will be referenced.

$$M = \frac{\text{Actual V/Hz Condition}}{\text{V/Hz Pickup Setting}}$$

If the results obtained from these procedures do not fall within specified tolerances, look for:

- Procedural inconsistencies. (Example: The start pulse to the timer does not always begin on the zero crossing.)
- The inherent error of the test equipment used. The function generator must be extremely stable in frequency and magnitude. A Doble F2500 with hand controller or Multi Amp Epoch 30 are suggested. Also, the digital voltmeter must be stable and accurate at 10 Hz.

NOTE

It is not necessary to perform the tests in sequential order. Testing may be initiated at any specific test. However, all tests use the same initial front panel switch positions.

Pickup

Step 1. Connect the unit as shown in Figure 5-1.

Step 2. Adjust the front panel thumbwheel switches as follows:

- INST. PICKUP - 2.00 V/Hz
- TIME TRIP PICKUP - 2.00 V/Hz
- TIME DIAL - 0.1
- RESET - 0.1
- ALARM PICKUP - 2.00 V/Hz
- ALARM TIME DELAY - 0.0

Step 3. Adjust the input frequency to 60 Hz. Increase the input voltage to a point where the TIME TRIP PICKUP LED just illuminates, and record the voltage. (Recorded voltage should be 120 Vac \pm 1.0 hertz.)

Step 4. Repeat step 3 for the alarm and instantaneous outputs.

Step 5. At this time, other V/Hz settings for pickup may be verified using the procedures in steps 3 through 5. Pickup accuracies are as follows.

Frequency	Accuracy at 25°C
40-72 hertz	\pm 1 hertz
20-40 hertz	\pm 2 hertz
3-20 hertz	\pm 8 hertz

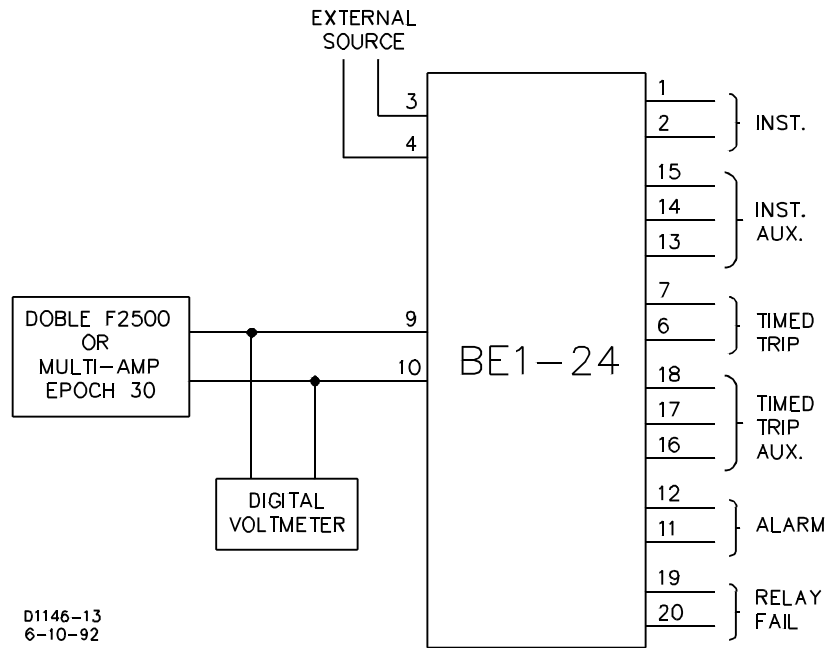

Figure 5-1. Test Setup Diagram

Instantaneous Time Verification

Step 1. Connect the unit as shown in Figure 5-1.

Step 2. Adjust the front panel thumbwheel switches as follows:

- INST. PICKUP - 2.00 V/Hz
- TIME TRIP PICKUP - 2.00 V/Hz
- TIME DIAL - 0.1
- RESET - 0.1
- ALARM PICKUP - 2.00 V/Hz
- ALARM TIME DELAY - 0.0

Step 3. Apply 180 Vac at 60 Hz to the unit under test ($M = 1.5$). Measure and record the interval from initiation of input condition to instantaneous output contact transition. Verify that the recorded time is less than eight cycles.

$$M = \frac{\text{Actual V/Hz condition}}{\text{V/Hz Setting}}$$

Definite Time Delay Alarm

- Step 1. Connect the unit as shown in Figure 5-1.
- Step 2. Adjust the front panel thumbwheel switches as follows:
- INST. PICKUP - 2.00 V/Hz
 - TIME TRIP PICKUP - 2.00 V/Hz
 - TIME DIAL - 0.1
 - RESET - 0.1
 - ALARM PICKUP - 2.00 V/Hz
 - ALARM TIME DELAY - 0.0
- Step 3. Adjust the ALARM TIME DELAY to 0.1.
- Step 4. Apply 130 Vac at 60 Hz to the relay and record the interval from initiation to alarm output contact transition. (Time should be 0.1 ± 0.08 seconds.)
- Step 5. Repeat step 4 for ALARM TIME DELAY settings of 3.0 and 9.9. Recorded times should be as follows.

<u>Setting</u>	<u>Expected Time</u>
3.0	3.0 ± 0.075 seconds
9.9	9.9 ± 0.099 seconds

Inverse Square Timing

- Step 1. Connect the unit as shown in Figure 5-1.
- Step 2. Adjust the front panel thumbwheel switches as follows:
- INST. PICKUP - 2.00 V/Hz
 - TIME TRIP PICKUP - 2.00 V/Hz
 - TIME DIAL - 0.1
 - RESET - 0.1
 - ALARM PICKUP - 2.00 V/Hz
 - ALARM TIME DELAY - 0.0
- Step 3. Prepare to apply 144 Vac at 60 Hz ($M = 1.2$) to the relay and measure the elapsed time from initiation of the input condition to timed trip output contact transition.
- Verify that the timed interval from initiation of input condition to transition of the timed trip output contacts agrees with the characteristic curve graph in Section 1 (estimated 2.1 ± 0.2 seconds).

Step 4. Repeat step 3 for TIME DIAL settings of 1.0 and 0.0. Elapsed times should be as follows.

<u>Setting</u>	<u>Elapsed Time</u>
1.0	20 \pm 3 seconds
0.0	200 \pm 20 seconds

Step 5. Repeat steps 3 and 4 with input conditions of 180 Vac at 60 Hz (M = 1.5).

Elapsed times should be as follows.

<u>Setting</u>	<u>Elapsed Time</u>
0.1	0.45 \pm 0.5 seconds
1.0	3.7 \pm 0.4 seconds
0.0	36 \pm 4 seconds

This completes the operational test procedures.

This page intentionally left blank.

SECTION 6 • MAINTENANCE

GENERAL

BE1-24 Volts Per Hertz Overexcitation Relays require no preventive maintenance other than a periodic operational test (refer to Section 5 for operational test procedure). If factory repair is desired, contact the Customer Service Department of the Power Systems Group, Basler Electric, for a return authorization number prior to shipping.

IN-HOUSE REPAIR

In-house replacement of individual components may be difficult and should not be attempted unless appropriate equipment and qualified personnel are available.

CAUTION

Substitution of printed circuit boards or individual components does not necessarily mean the relay will operate properly. Always test the relay before placing it in operation.

Replacement parts may be purchased locally. The quality of replacement parts must be at least equal to that of the original components.

Where special components are involved, Basler Electric part numbers may be obtained from the number stamped on the component or assembly, the schematic, or parts list. These parts may be ordered directly from Basler Electric. When complete boards or assemblies are needed, the following information is required.

1. Relay model and style number
2. Relay serial number
3. Board or assembly
 - a) Part number
 - b) Serial number
 - c) Revision letter
4. The name of the board or assembly.

STORAGE

This protective relay contains aluminum electrolytic capacitors which generally have a life expectancy in excess of 10 years at storage temperatures less than 40°C. Typically, the life expectancy of the capacitor is cut in half for every 10°C rise in temperature. Storage life can be extended if, at one-year intervals, power is applied to the relay for a period of thirty minutes.

TEST PLUG

The test plug (Basler part number 10095 or G.E. part number 12XLA12A1) provides a quick, easy method of testing relays without removing them from their case. The test plug is simply substituted for the connection plug. This provides access to the external stud connections as well as to the internal circuitry.

The test plug consists of a black and red phenolic molding with twenty electrically separated contact fingers connected to ten coaxial binding posts. The ten fingers on the black side are connected to the inner binding posts (black thumb nuts) and tap into the relay internal circuitry. The ten fingers on the red side of the test plug are connected to the outer binding posts (red thumb nuts) and also connect to the relay case terminals.

When testing circuits connected to the bottom set of case terminals, the test plug is inserted with the numbers 1 through 10 facing up. Similarly, when using the test plug in the upper part of the relay, the numbers 11 through 20 are faceup. It is impossible, due to the construction of the test plug, to insert it with the wrong orientation.

SECTION 7 • MANUAL CHANGE INFORMATION

CHANGES

This section contains information concerning the previous editions of the manual. The substantive changes to date are summarized below.

Table 7-1. Summary of Changes

Revision	Summary of Changes	ECA/Date
A	In step 2 of page 4-3: "... 140 Vac \pm 1.0%" originally read (erroneously) "... 70 \pm 0.7 Vac."	11198/09-07-89
B	Improved relay accuracy, repeatability, and response. Replaced Figures 1-1, 1-2, and 1-3 to illustrate new characteristic curves. Replaced Figure 3-3 to clarify microprocessor calculation sequence. Minimum inverse time delay changed from 0.2 seconds to .25 seconds. Added additional recommended test equipment to operational test procedure.	12199/10-30-91
C	Changed the manual to current instruction manual format. Sensing input range was specified as 3 to 78 hertz and is now specified as 3 to 72 hertz. Added Figure 1-5 (Inverse Square characteristic Curves graphed with multiples of pickup on the y axis and time in seconds on the x axis.	12599/10-30-92
D	Corrected power supply types in Section 1, <i>Specifications</i> , Power Supply, added burden data, UL recognized data, and corrected RFI data. Changed Section 3, <i>Functional Description</i> , <i>Inverse Square Timing</i> , to clarify the reset time equation and corrected the time dial setting associated with the equation (was 65, is now 25). Removed all Testing data from Section 4, <i>Installation and Testing</i> and created a new Section 5, <i>Testing</i> . All subsequent section numbers were increase by one number.	15702/06-21-96
E	Deleted reference to Service Manual 9 1716 00 620. Updated the Dielectric Test information. Changed Input Voltage Range and Burden Data in Power supply table in <i>Specifications</i> . Corrected Style Chart by changing power supply type Z from "230 Vac" to "240 Vac" and deleting "Selectable" from type Y. Added new power supply information to Section 3 in <i>Power Supply</i> paragraph starting with "Basler Electric enhanced the power supply design...". Added new dimension figures to include all options available (M1 Double-Ended showing both mounting positions). Added a note to Figure 4-9 to clarify that the aux. output is either NO or NC. Changed the format of the manual.	16941/08-11-98

This page intentionally left blank.



12570 State Route 143
Highland IL 62249-1074 USA
Tel: +1 618.654.2341
Fax: +1 618.654.2351
email: info@basler.com

No. 59 Heshun Road Loufeng District (N)
Suzhou Industrial Park
215122 Suzhou
P.R. CHINA
Tel: +86 512.8227.2888
Fax: +86 512.8227.2887
email: chinainfo@basler.com

111 North Bridge Road
15-06 Peninsula Plaza
Singapore 179098
Tel: +65 68.44.6445
Fax: +65 68.44.8902
email: singaporeinfo@basler.com