

Application Note

Basler Makes It Easy to Apply a DECS-250 as a Replacement to a DECS-200

Basler Electric’s new DECS-250 digital excitation control system was developed with all of the features and capabilities of the popular DECS-200. Additionally, the DECS-250 has new features designed to meet the latest demands of our customers. These features include enhanced communication abilities (including load sharing over Ethernet), additional data logging features, integrated PLC with extendable I/O, integrated PSS and enhanced protective features.

The DECS-250 was designed to make the change from the DECS-200 as simple as possible for the user. This easy change allows our customer to benefit from the added features, functions and flexibility of the DECS-250’s technological advancements, all while minimizing the amount of machine down time needed to perform the upgrade.

By using an optional escutcheon plate, the DECS-250 will use the same holes as a DECS-200 unit. While the DECS-250 plate is not the same size as the DECS-200 plate, the hole placements is no redrilling of holes is required to upgrade from a DECS-200. See Figures 1 and 2.

When developing the DECS-250, careful consideration and planning was given to the layout of the product.

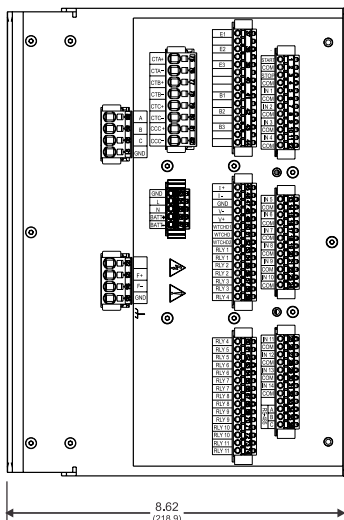

Figure 3: DECS-250 side panel drawing

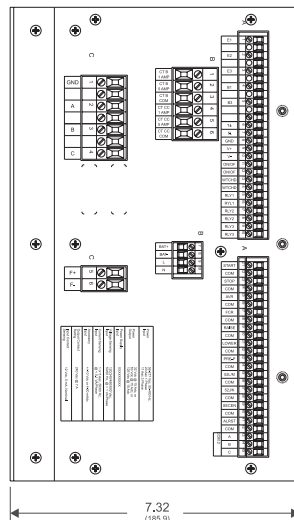

Figure 4: DECS-200 side panel drawing

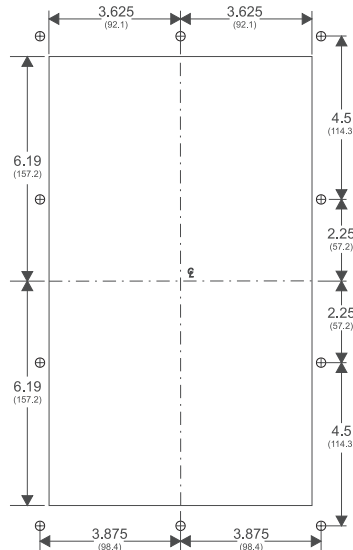

Figure 1: Cutout Drawing for DECS-250 and DECS-200 Panel Mount

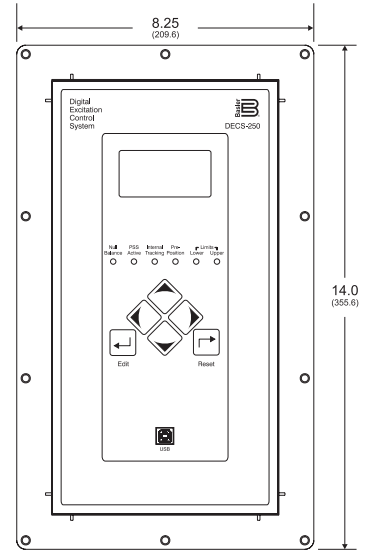

Figure 2: DECS-250 Escutcheon Plate Dimensions

As a result, the DECS-250 and terminal locations are in the same or similar location on the unit as the DECS-200. This eliminates the need for the wiring harnesses to be rewired or extended during the replacement process. See Figures 3 and 4.

In addition to not needing to rewire the system, the Modbus® registers in the DECS-250 is the same as the DECS-200. This eliminates the need for remapping of the Modbus/SCADA systems. The only thing required of the user is to verify the communication parameters in BESTCOMSPPlus®. When replacing DECS-200 units in a redundant setup, the DECS-250 only needs to replace the failed unit, then be placed as the primary unit. DECS-250 has the ability to communicate with DECS-200 for external auto-tracking, as long as the DECS-250 is placed as the primary unit.

One of the enhanced features of the DECS-250 is the fully programmable logic. BESTlogic™Plus gives the user flexibility to map inputs, outputs, functions, and controls together in custom logic schemes. However, the default logic, as shipped from the factory, is preprogrammed into the DECS-250 to allow the same operation as the default logic in the DECS-200. By using the DECS-200 logic as

a basis, commissioning time is further reduced. The user still has the full ability to extend or add additional logic as required by the system. See Figures 5, 6 and 7.

For more information

It's easy to see that the DECS-250's design allows for an easy upgrade from a DECS-200 by reducing as much of the labor and setup during the conversion process as possible. If you have any questions, consult the Basler factory at +1 618.654.2341 or visit www.basler.com. If you would like additional details about the DECS-250, request a copy of the product bulletin (part no. SZPBULL) or the instruction manual (part no. 9440300990).

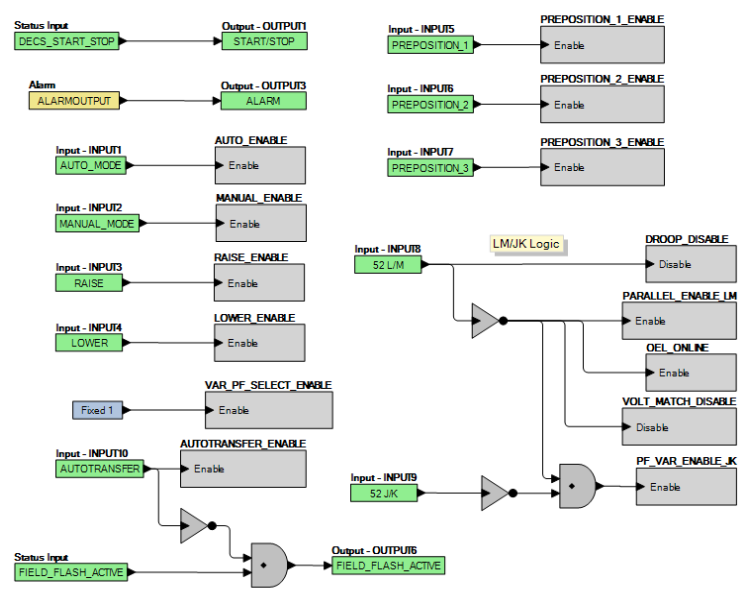

Figure 5: Default Logic - Dynamic Logic 1 Tab

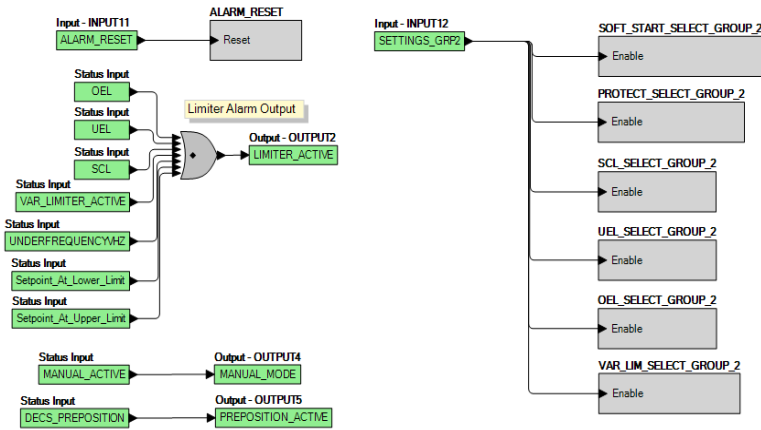

Figure 6: Default Logic - Dynamic Logic 2 Tab

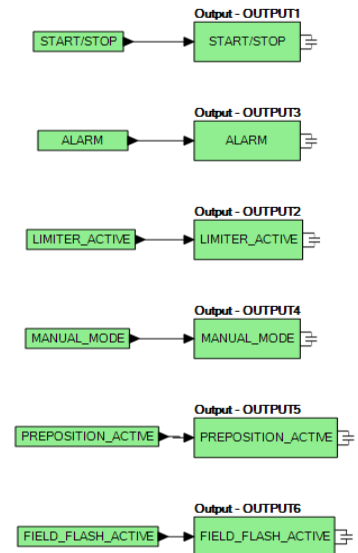
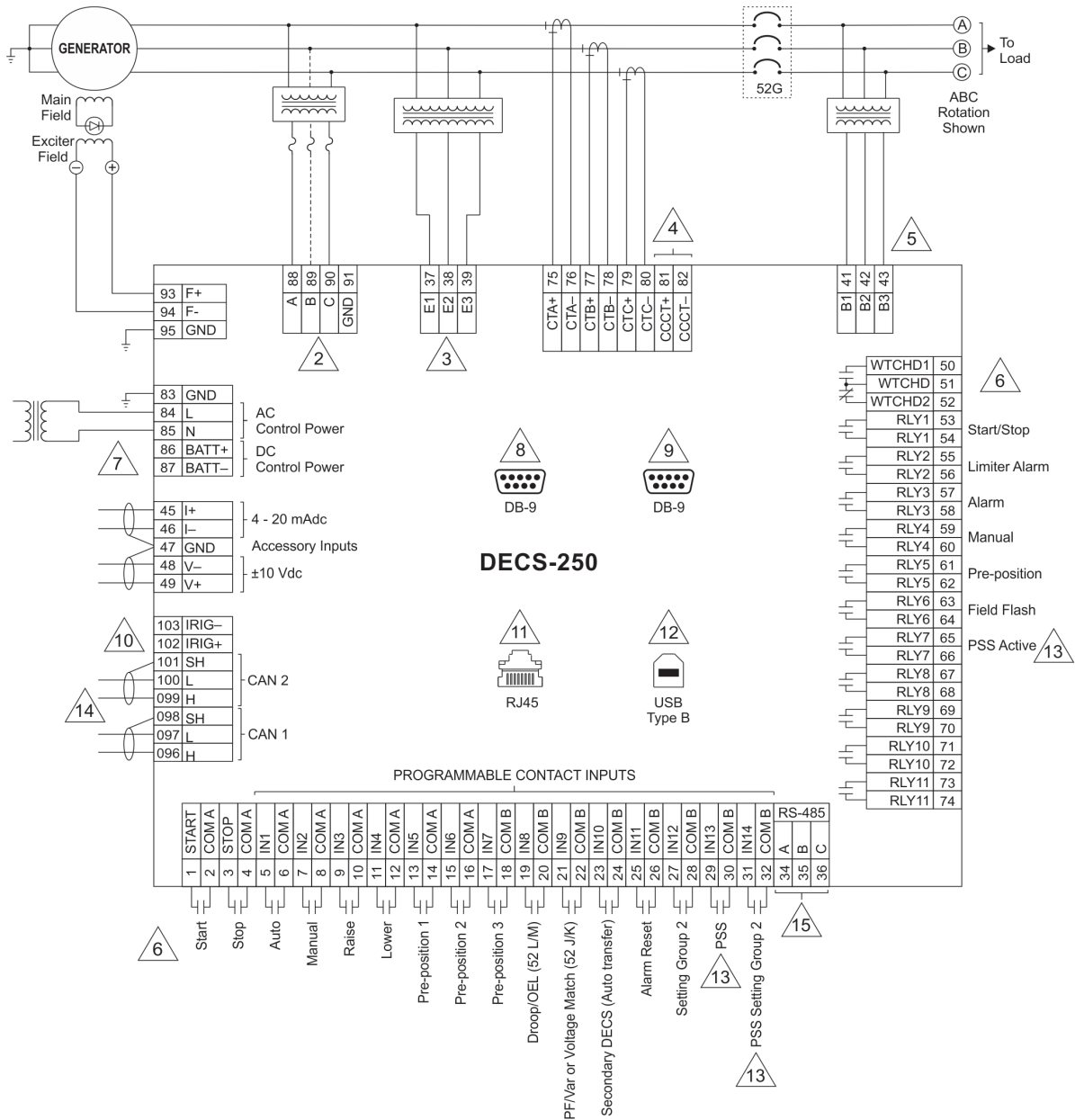

Figure 7: Default Logic - Physical Outputs Tab

Note

Basler Electric attempts to make settings and configuration updates as easy as possible for the user. However, product enhancements, updates, and feature additions may create differences between devices. It is recommended that all settings are reviewed and system performance is verified. It is not the intention of this document to identify all changes or differences between devices. For more information, please refer to the appropriate instruction manual. If there are questions or concerns, contact our Technical Sales Support staff for assistance.



NOTES

2. Operating (bridge) power input. For single-phase power, omit one phase connection. See Power Inputs or Specifications for operating power ratings.
3. Generator voltage sensing input. Potential transformer required if line voltage exceeds 600 Vac.
4. Cross-current compensation input, 1 Aac or 5 Aac.
5. Connections required only if voltage matching, sync-check, or auto synchronizer functions are used.
6. Labels indicate the functions assigned by the default programmable logic to the contact inputs and output contacts.
7. See Power Inputs or Specifications for control power input ratings.
8. RS-232 port used for communication with another DECS in a redundant DECS system.
9. Optional communication port (style xxxxxP) uses PROFIBUS protocol.
10. IRIG time synchronization input.
11. Ethernet communication port can be copper (style xxxxx1x) or fiber optic (style xxxxx2x) and uses Modbus communication protocol.
12. Type B USB jack for temporary, local communication.
13. This input/output is unassigned by default if the DECS-250 is not equipped with the optional PSS (style number xPxxxx).
14. If the DECS-250 is providing one end of the J1939 bus, a 120-ohm, 0.5-watt terminating resistor must be installed across terminals 96 (H) and 97 (L) for CAN 1 and 99 (H) and 100 (L) for CAN 2.
15. RS-485 port uses the Modbus RTU protocol for communication with other networked devices.

Figure 8: DECS-250 Interconnection Diagram

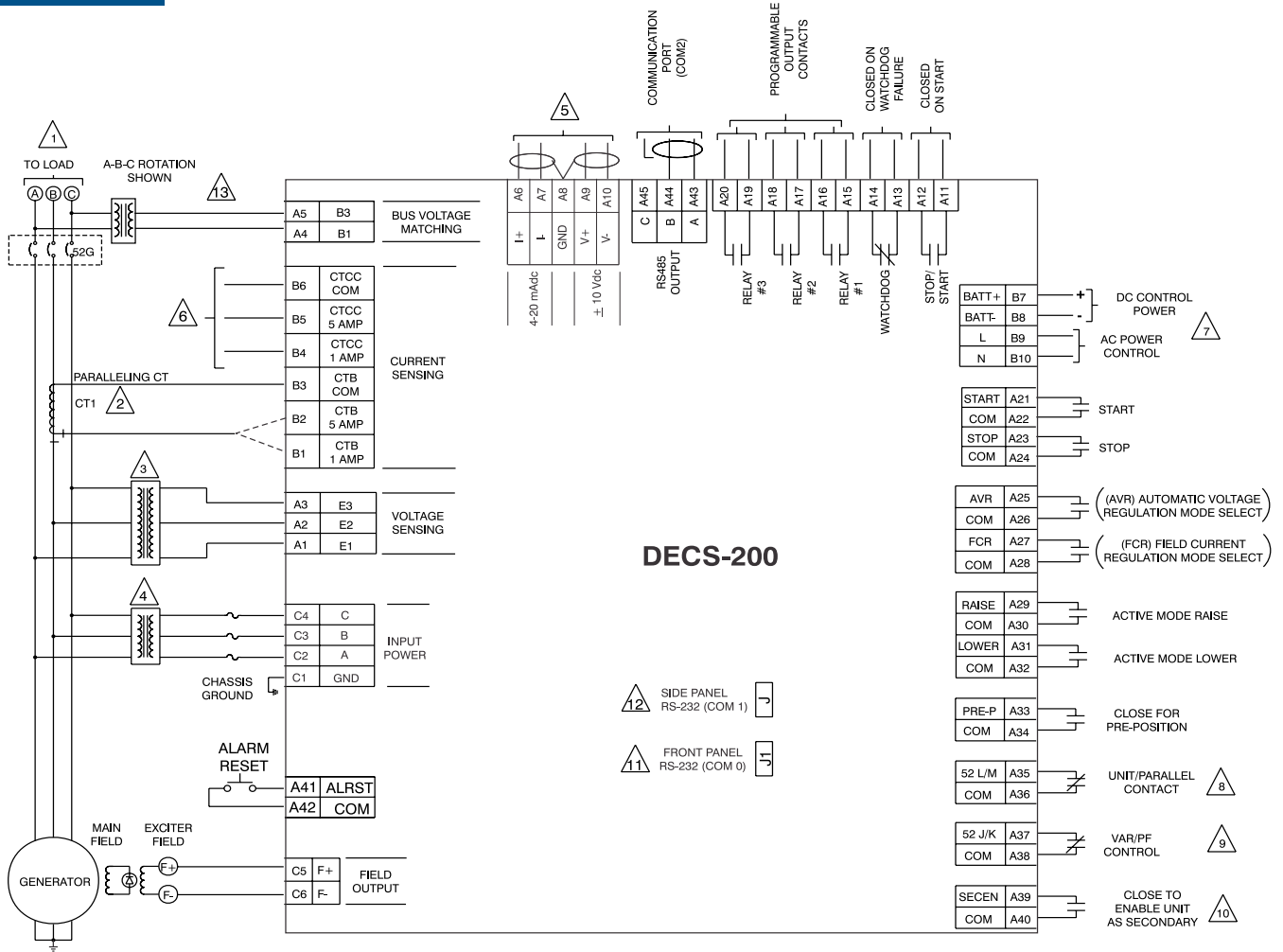

- 1 Phase sequence: A-B-C shown.
- 2 Current sensing input 1 or 5 Amps, 50/60 Hz @ <0.1 VA/Phase.
- 3 Voltage sensing input, 120/240/480/600 VAC, 50/60 Hz @ <0.1 VA/Phase. Potential Transformers required if line voltage exceeds 600 VAC.
- 4 Operating power input, reference specifications for voltage ratings. For single phase, omit one phase.
- 5 Accessory input, $\pm 10\text{Vdc}$ or 4-20mAdc.
- 6 Cross current compensation current input 1 or 5 Amps, 50/60 Hz @ <0.1 VA/Phase.
- 7 Control power input, reference specifications for voltage ratings.
- 8 Unit/Parallel contact, closed for unit, open for parallel operation.
- 9 VAR/PF control, open to enable Var or PF function.
- 10 Input contact to enable unit as secondary when operating in redundant mode with dual DECS-200.
- 11 Port used for communication with computer (BESTCOMS™ software).
- 12 Port used for communication connection to another DECS-200 when used in redundant mode operation.
- 13 Connection required only if voltage matching is utilized.

Figure 9: DECS-200 Interconnection Diagram