

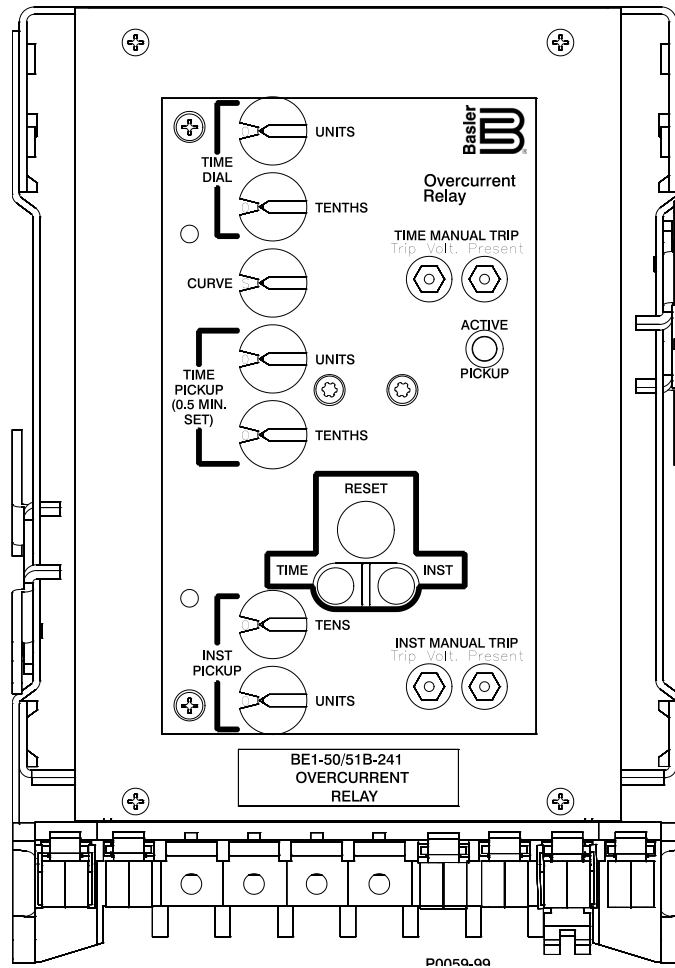



BE1-50/51B-241 Overcurrent Relay

Instruction Manual



 **WARNING:** California's Proposition 65 requires special warnings for products that may contain chemicals known to the state of California to cause cancer, birth defects or other reproductive harm. Please note that by posting this Proposition 65 warning, we are notifying you that one or more of the Proposition 65 listed chemicals may be present in products we sell to you. For more information about the specific chemicals found in this product, please visit <https://www.basler.com/Prop65>.

Preface

This instruction manual provides information about the installation and operation of the Overcurrent Relay BE1-50/51B-241. To accomplish this, the following information is provided:

- General information and specifications
- Controls and indicators
- Functional description
- Installation and maintenance
- Testing

Conventions Used in this Manual

Important safety and procedural information is emphasized and presented in this manual through Warning, Caution, and Note boxes. Each type is illustrated and defined as follows.

Warning!

Warning boxes call attention to conditions or actions that may cause personal injury or death.

Caution

Caution boxes call attention to operating conditions that may lead to equipment or property damage.

Note

Note boxes emphasize important information pertaining to BE1-50/51B-241 installation or operation.



12570 State Route 143
Highland IL 62249-1074 USA

www.basler.com

info@basler.com

Tel: +1 618.654.2341

Fax: +1 618.654.2351

© 2026 by Basler Electric

All rights reserved

First printing: March 2010

Warning!

READ THIS MANUAL. Read this manual before installing, operating, or maintaining the Overcurrent Relay. Note all warnings, cautions, and notes in this manual as well as on the product. Keep this manual with the product for reference. Failure to follow warning and cautionary labels may result in personal injury or property damage. Exercise caution at all times.

To prevent personal injury or equipment damage, only qualified personnel should install, operate, or service this system.

Basler Electric does not assume any responsibility to compliance or noncompliance with national code, local code, or any other applicable code. This manual serves as reference material that must be well understood prior to installation, operation, or maintenance.

For terms of service relating to this product and software, see the *Commercial Terms of Products and Services* document available at <https://www.basler.com/customer-terms-and-conditions>.

It is not the intention of this manual to cover all details and variations in equipment, nor does this manual provide data for every possible contingency regarding installation or operation. The availability and design of all features and options are subject to modification without notice. Over time, improvements and revisions may be made to this publication. Before performing any of the following procedures, contact Basler Electric for the latest revision of this manual.

The English-language version of this manual serves as the only approved manual version.

Revision History

The following information provides a historical summary of the changes made to the BE1-50/51B-241 instruction manual (9252000792). Revisions are listed in reverse chronological order.

Manual Revision and Date	Change
F, May 2026	<ul style="list-style-type: none"> • Minor text edits
E, December 2019	<ul style="list-style-type: none"> • Changed Instantaneous Element 50-A range to 1-99 Aac and added Note box about minimum current required to energize both instantaneous elements in the <i>General Information</i> chapter • Added Prop 65 warning on back of cover page • Minor text edits throughout manual
D, August 2014	<ul style="list-style-type: none"> • Added note about relay compatibility in older CO relay applications
C, October 2012	<ul style="list-style-type: none"> • Improved description of operating-current jumpers for the targets
B, September 2011	<ul style="list-style-type: none"> • Changed the 50-B output terminals in all applicable illustrations from 10 and 7 to 1 and 7
A, July 2011	<ul style="list-style-type: none"> • Swapped the location of terminals 1 and 7 in all references • Updated the Active/Pickup Indicator description • Added the year of the IEEE listings in the General Information chapter
–, March 2010	<ul style="list-style-type: none"> • Initial release



Contents

General Information	1-1
Controls and Indicators	2-1
Functional Description.....	3-1
Installation	4-1
Testing.....	5-1
Characteristic Curves.....	6-1



1 • General Information

The BE1-50/51B-241 protective relay is a direct replacement for ABB/Westinghouse type CO and COM relays housed in an FT-21 case. The BE1-50/51B-241 has a 5-ampere current sensing input. Compatible ABB/Westinghouse model numbers are listed in Table 1-1.

Table 1-1. ABB/Westinghouse Relays Suitable for Direct Replacement

Catalog Number	Curve Type
CO-2	Short Time
CO-5 or COM-5	Long Time
CO-6 or COM-6	Definite
CO-7 or COM-7	Moderately Inverse
CO-8 or COM-8	Inverse
CO-9 or COM-9	Very Inverse
CO-11 or COM-11	Extremely Inverse

Note

If replacing a CO relay manufactured prior to 1966, please contact Basler Electric to verify compatibility.

To replace an existing ABB/Westinghouse type CO or COM relay, perform the following steps.

1. Select the desired relay settings on your new BE1-50/51B-241 relay.
2. Remove the existing Westinghouse relay cradle.
3. Insert the new relay cradle.
4. Close the knife-blade switches.
5. Install the new Basler Electric replacement cover glass into existing cover and secure with the captive thumbnut.

The BE1-50/51B-241 relay is self-powered, compatible with 50 or 60 Hz power systems, and has three protection elements: one time overcurrent (51) element and two instantaneous overcurrent (50) elements. The 51 element offers timing characteristic curves similar to those used by GE IAC and Westinghouse CO/COM relays.

Features

A wide range of pickup settings and front panel selectable time characteristics permit applications involving coordination with fuses, reclosers, cold load pickup, motor starting, and fixed time requirements. In addition, an integrating reset function is available to simulate the disk reset of electromechanical relays.

The BE1-50/51B-241 overcurrent relay has the following standard features.

- Independent time and instantaneous elements
- A secure method to manually trip the breaker at the relay front panel
- Direct reading front panel controls
- Minimum pickup setting for safety during installation
- Time characteristics extend to a pickup multiple of 40
- Rugged draw-out construction
- Gravity latching targets retain indication without power
- Built-in accuracy eliminates internal adjustments
- Minimum transient overreach

- Field selectable characteristic curve selection similar to GE IAC or ABB/Westinghouse CO/COM type curves
- Field selectable instantaneous or integrating reset
- Field selectable 50 or 60 Hz operation
- Field selectable 0.0 or 0.1 second, fixed, instantaneous delay

Internal switches provide for selecting system-operating frequencies of 50 or 60 Hz, instantaneous element delays of 0.0 or 0.1 second, characteristic curve group selection for either GE IAC or Westinghouse CO/COM type curves, and instantaneous or integrating reset characteristics. Switch locations and descriptions are provided in the *Controls and Indicators* chapter.

Advantages

The BE1-50/51B-241 overcurrent relay has many advantages over other overcurrent relays. The primary advantages are:

- Time characteristics are defined by equations and graphs
- Field selectable time characteristics
- Very low burden extends the linear range of the CTs
- Self-powered from the sensed current
- Continuous automatic calibration

The BE1-50/51B-241 overcurrent relay may be tested without removing the relay from the case. Shorting contacts are provided for all current inputs when the connection plugs or relay chassis is removed from the relay case.

Specifications

BE1-50/51B-241 electrical and physical specifications are listed in the following paragraphs.

Time Overcurrent (51) Element

Pickup

Setting Range:	0.5 to 15.9 Aac
Setting Increment:	0.1 Aac
Accuracy:	Sum of $\pm 2\%$ and ± 25 mAac

Dropout

Dropout occurs at 95% of pickup value.

Characteristic Curves

Available curve types follow IEEE Standard C37.112 (1996) and emulate standard GE IAC, Westinghouse CO/COM, and BS142 curves. The *Characteristic Curves* chapter illustrates the available curves and lists the applicable constants.

Curve Types:	Short Inverse, Long Inverse, Definite Time, Moderately Inverse, Inverse, Very Inverse, Extremely Inverse, BS142 Very Inverse, BS142 Extremely Inverse, Fixed Time
Time Multiplier:	11 curves for each characteristic
Timing Accuracy:	± 1 cycle, $\pm 2\%$. This accuracy applies to the range of 1.3 to 40 times tap and is for a given measured multiple of tap.

Fixed Timing

Setting Range:	0.1 to 9.9 s
Setting Increment:	0.1 s
Timing Accuracy:	± 1 cycle, $\pm 2\%$ of the time to trip for time dial settings ≥ 0.1

Reset

Integrating:	Simulates the disk reset of electromechanical relays and begins when the current decreases below 95% of pickup. The <i>Characteristic Curves</i> chapter illustrates the integrating reset characteristic curve and equation.
Instantaneous:	Reset occurs when current decreases to 95% of the pickup level with no intentional time delay.

Instantaneous Overcurrent A (50-A) Element

Note
At least 2 A is required to energize both instantaneous elements at the same time. Therefore, only one instantaneous element can be set below 2 A.

Pickup

Setting Range:	1 to 99 Aac
Setting increment:	1 Aac
Accuracy:	Sum of $\pm 2\%$ and ± 25 mAac

Dropout

Dropout occurs at 95% of pickup value.

Time Delay

Switch selectable with no intentional delay (SW3-2 OFF) or a fixed delay of 100 ms (SW3-2 ON). The *Characteristic Curves* chapter illustrates the characteristic curve for the 50-A and 50-B elements.

Instantaneous Overcurrent B (50-B) Element

Note
At least 2 A is required to energize both instantaneous elements at the same time. Therefore, only one instantaneous element can be set below 2 A.

Pickup

Setting Range:	1 to 15.9 Aac
Setting increment:	0.1 Aac
Accuracy:	Sum of $\pm 2\%$ and ± 25 mAac

Dropout

Dropout occurs at 95% of pickup value.

Time Delay

Fixed at no intentional delay. The *Characteristic Curves* chapter illustrates the characteristic curves for the 50-A and 50-B elements.

Reset Characteristic

Resets within 16 ms of when sensed current decreases below the pickup level.

Current Sensing Input

Continuous Rating: 14 Aac*
 1 Second Rating: 400 Aac

* Continuous rating is 14 Aac for temperatures up to 45°C. See Figure 1-1 for de-rating curve.

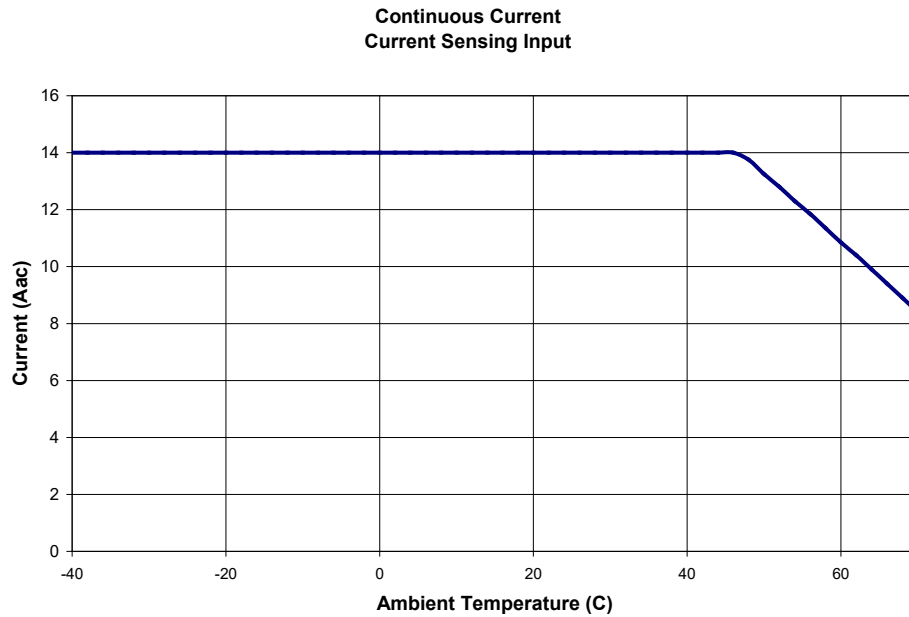

Figure 1-1. Current Sensing Input Derating Curve (BE1-50/51B-241)

Burden

At 0.5 Aac: 2.8 Ω
 At 5.0 Aac: 0.3 Ω

Figure 1-2 illustrates the current sensing input burden characteristic.

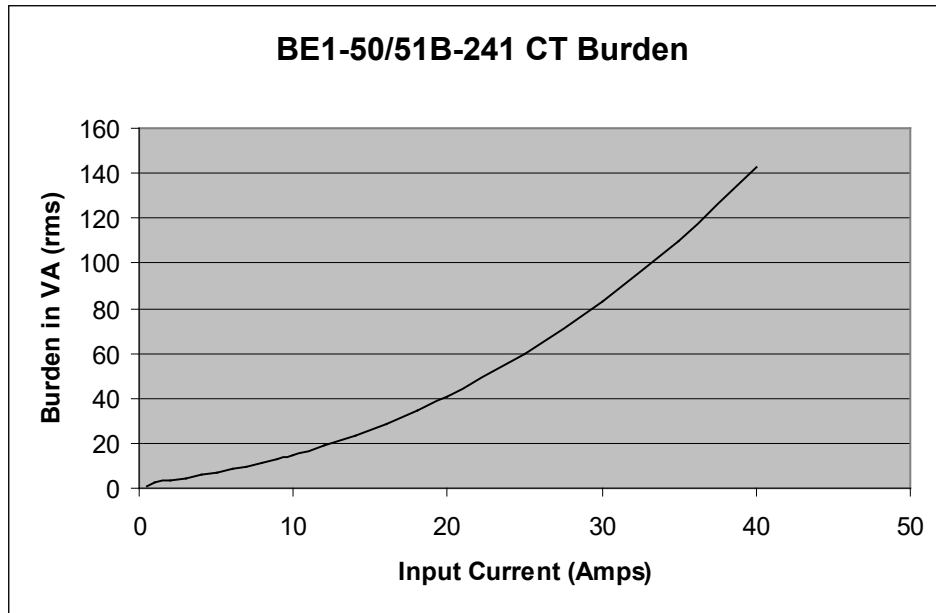

Figure 1-2. Current Sensing Input Burden (BE1-50/51B-241)

Frequency Response

A change of ± 5 Hz from the nominal 50/60 Hz current causes $<0.5\%$ change in the current required for pickup.

Transient Response

$<10\%$ overreach with system time constants up to 40 ms.

Harmonic Rejection

Rejection of odd and even harmonics is illustrated in Figure 1-3.

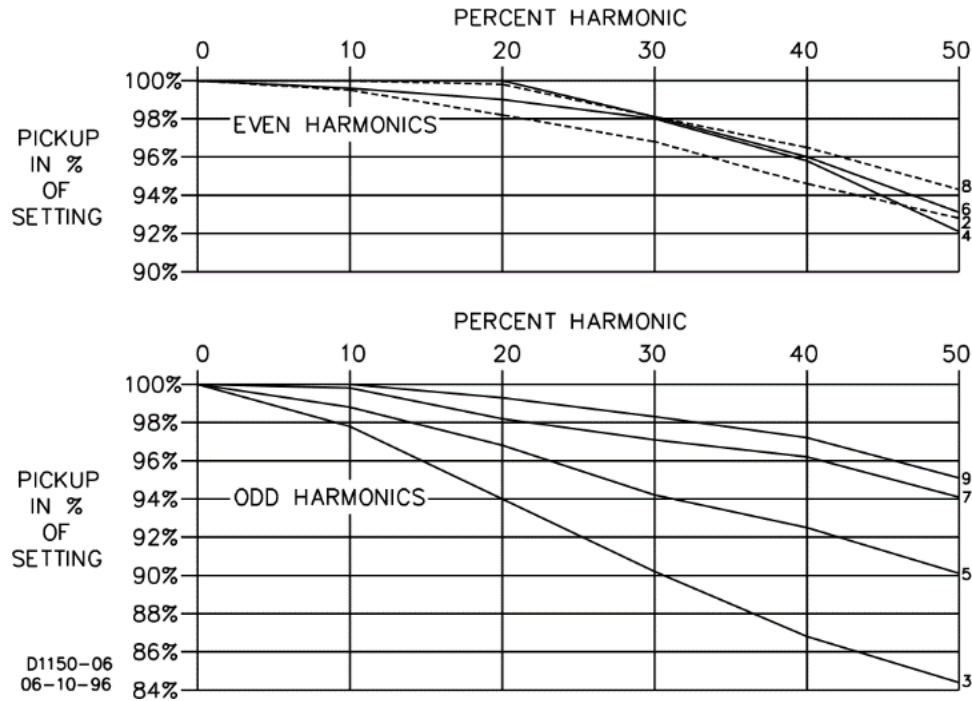

Figure 1-3. Harmonic Rejection

Target Indicators

A gravity-latched, manually-reset, current-operated target indicator is provided for the time-overcurrent (51) trip output and the instantaneous overcurrent A (50-A) trip output. A target indicator is not provided for the 50-B trip output. The level of trip circuit current required to operate each target is individually controlled by a circuit board jumper. See the *Controls and Indicators* chapter for jumper locations and function assignments

Target Operate Current

Jumper Position—Pins 1 and 2: Must operate ≥ 2.25 A; must not operate < 900 mA.*
 Jumper Position—Pins 2 and 3: Must operate ≥ 200 mA; must not operate < 80 mA.*

* See *Output Contacts* for the maximum acceptable levels of trip circuit currents.

Output Contacts

Output contacts are surge protected and rated as follows.

Resistive Ratings

120/240 Vac: Make 30 amperes for 0.2 seconds, carry 7 amperes for 2 minutes, 3 amperes continuously, and break 5 amperes.
 125/250 Vdc: Make 30 amperes for 0.2 seconds, carry 7 amperes for 2 minutes, 3 amperes continuously, and break 0.3 ampere.

Inductive Ratings

120/240 Vac, 125/250 Vdc: Make and carry 30 amperes for 0.2 seconds, carry 7 amperes for 2 minutes, 3 amperes continuously, and break 0.3 ampere. (L/R = 0.04).

Terminal Assignments

51 Element: 1, 10
 50-A Element: 2, 10
 50-B Element: 1, 7

Type Tests

Isolation:	IEEE C37.90-2005
Transient Surge:	IEEE C37.90.1-2004
Radiated Interference:	IEEE C37.90.2-2004
Electrostatic Discharge:	IEEE C37.90.3-2006
Vibration:	IEC 255-21-1
Shock and Bump:	IEC 255-21-2

Environment

Operating Temperature:	-40 to 70°C (-40 to 158°F)
Storage Temperature:	-50 to 70°C (-58 to 158°F)

Physical

Weight:	4.3 lb (2.0 kg)
---------	-----------------



2 • Controls and Indicators

The BE1-50/51B-241 relay controls and indicators are located on the front panel and circuit board.

Front Panel Controls and Indicators

Front panel controls and indicators are illustrated in Figure 2-1 and described in Table 2-1. The locators and descriptions of Table 2-1 correspond to the locators shown in Figure 2-1.

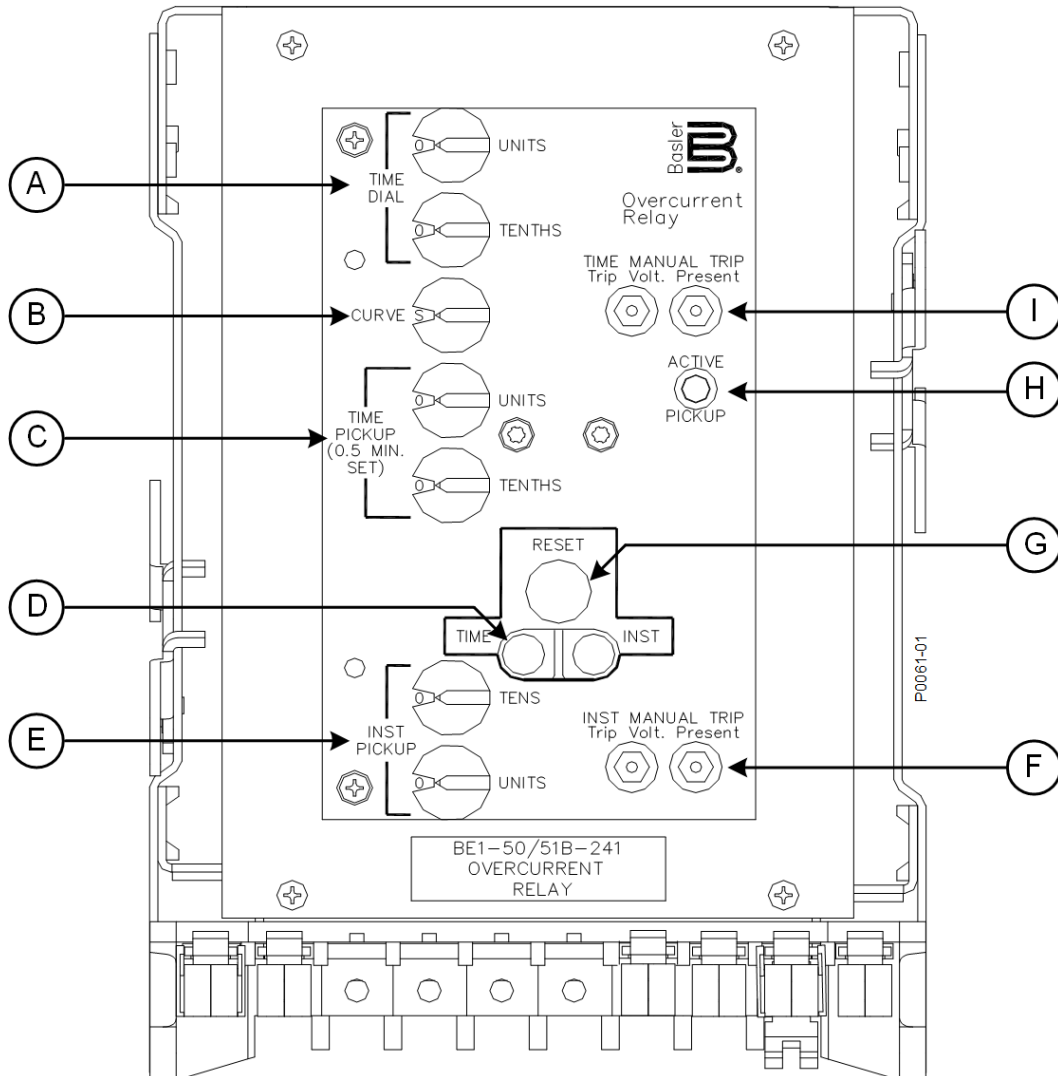

Figure 2-1. Front Panel Controls and Indicators

Table 2-1. Front Panel Controls and Indicators

Locator	Description		
A	<i>Time Overcurrent Time Dial Selector Switches.</i> These two rotary switches select the desired curve of the timing characteristic selected by the Curve Selector Switch (locator B). When a fixed time characteristic is used (Curve Selector Switch setting of A), the setting of these switches corresponds to a time delay of 0.0 to 9.9 seconds.		
B	<i>Curve Selector Switch.</i> This ten position rotary switch selects one of nine inverse timing characteristics or one fixed time function. Refer to the <i>Characteristic Curves</i> chapter for details about BE1-50/51B-241 timing characteristics.		
C	<i>Time Overcurrent Pickup Selector Switches.</i> These two rotary switches select the time overcurrent pickup current setting in amperes (UNITS and TENTHS). Adjusting these selector switches while the relay is in service may cause the relay to trip.		
D	<i>Target Indicators.</i> Red target indicators latch when the corresponding set of trip contacts closes and sufficient trip circuit current is detected. (The level of current that will trip each target indicator is jumper-selectable. See <i>Circuit Board Controls</i> for more information.) The Time target indicates the flow of current in the time overcurrent (51) trip circuit. The Inst target indicates the flow of current in the instantaneous overcurrent A (50-A) trip circuit. No target is provided for the instantaneous overcurrent B (50-B) trip circuit. Both target indicators are reset by pressing the target reset button (locator G).		
E	<p><i>Instantaneous Overcurrent A Pickup Selector Switches.</i> These two rotary switches select the instantaneous overcurrent A (50-A) pickup current setting in amperes (TENS and UNITS). Adjusting these selector switches while the relay is in service may cause the relay to trip.</p> <table border="1" data-bbox="448 974 1305 1155"> <thead> <tr> <th data-bbox="448 974 1305 1033">Note</th> </tr> </thead> <tbody> <tr> <td data-bbox="448 1033 1305 1155">When testing time overcurrent functions, instantaneous pickup settings of 00 will affect the calibration of the time functions. Time pickup settings of 00 also affect instantaneous functions.</td> </tr> </tbody> </table>	Note	When testing time overcurrent functions, instantaneous pickup settings of 00 will affect the calibration of the time functions. Time pickup settings of 00 also affect instantaneous functions.
Note			
When testing time overcurrent functions, instantaneous pickup settings of 00 will affect the calibration of the time functions. Time pickup settings of 00 also affect instantaneous functions.			
F	<i>Instantaneous Overcurrent Manual Trip Jacks.</i> These jacks are used to manually trip a breaker controlled by the 50-A trip output contacts. This is achieved by plugging a jumper wire, terminated with two standard 0.08 inch diameter phone-tip plugs, into the two jacks. These jacks do not activate the 50-B trip output contacts.		
G	<i>Target Reset Button.</i> This button is pressed to reset the two, gravity-latched target indicators (locator D).		
H	<p><i>Active/Pickup Indicator.</i> This bicolor LED indicates the level of current sensed by the relay. A green LED indicates that the relay is active but not picked up. The LED changes to red when the sensed current exceeds the time overcurrent pickup setting and back to green when the sensed current decreases below 95% of the time overcurrent pickup setting.</p> <table border="1" data-bbox="448 1533 1305 1738"> <thead> <tr> <th data-bbox="448 1533 1305 1591">Note</th> </tr> </thead> <tbody> <tr> <td data-bbox="448 1591 1305 1738">A minimum of 0.5 A (5A units) or 0.1 A (1A units) is required to light the LED. The LED may not turn green (active) before turning red (picked up) at the 0.5 A pickup setting on 5A units or 0.1 A pickup setting on 1A units.</td> </tr> </tbody> </table>	Note	A minimum of 0.5 A (5A units) or 0.1 A (1A units) is required to light the LED. The LED may not turn green (active) before turning red (picked up) at the 0.5 A pickup setting on 5A units or 0.1 A pickup setting on 1A units.
Note			
A minimum of 0.5 A (5A units) or 0.1 A (1A units) is required to light the LED. The LED may not turn green (active) before turning red (picked up) at the 0.5 A pickup setting on 5A units or 0.1 A pickup setting on 1A units.			
I	<i>Time Overcurrent Manual Trip Jacks.</i> These jacks are used to manually trip a breaker controlled by the 51 trip output contacts. This is achieved by plugging a jumper wire, terminated with two standard 0.08 inch diameter phone-tip plugs, into the two jacks.		

Circuit Board Controls

Circuit board controls consist of two rotary selector switches, a four-position slide switch, and two jumpers. Circuit board controls are illustrated in Figure 2-2 and described in Table 2-2. The locators and descriptions of Table 2-2 correspond to the locators shown in Figure 2-2.

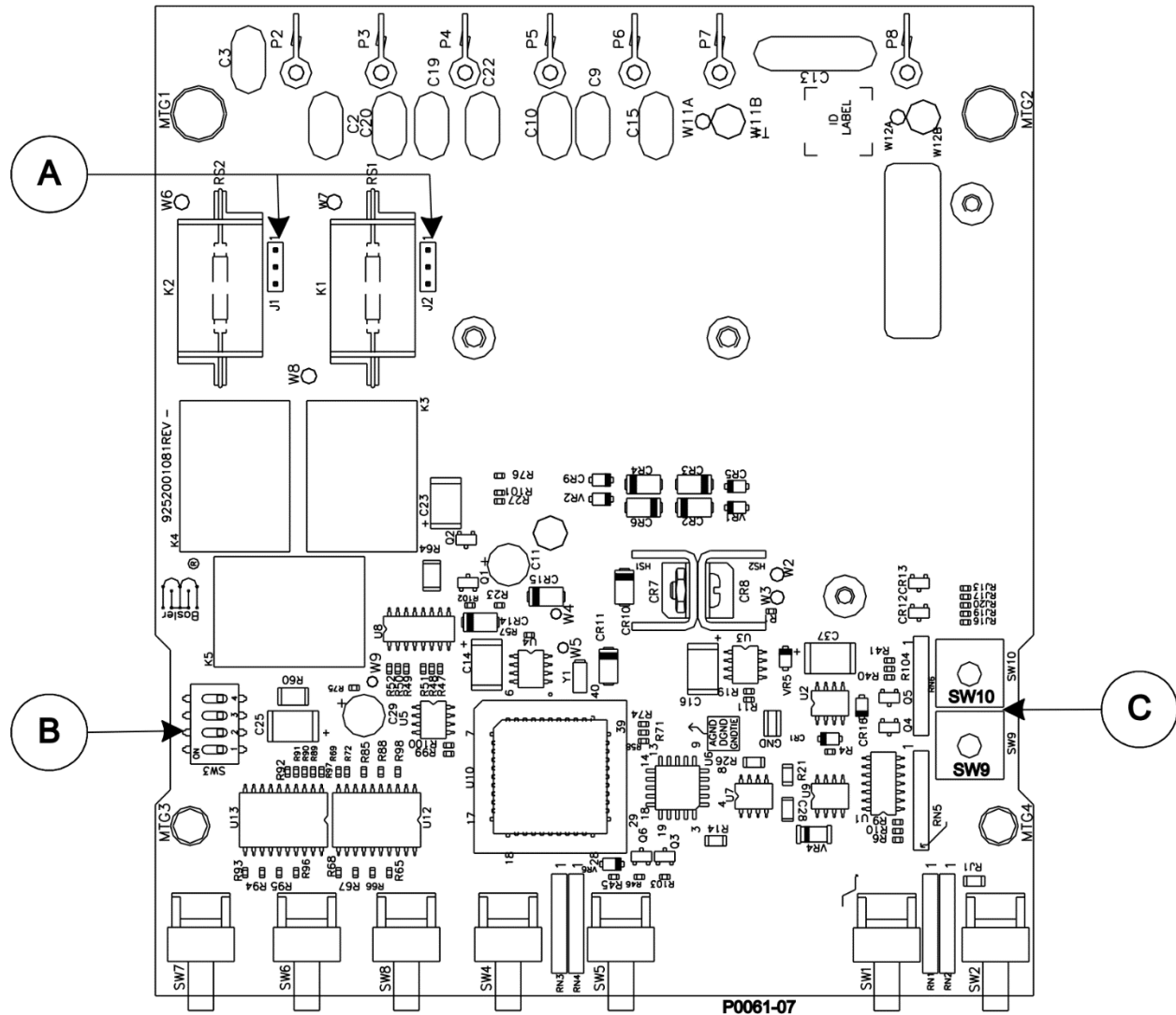

Figure 2-2. Circuit Board Controls

Table 2-2. Circuit Board Controls

Locator	Description
A	<p><i>Target Operating Current Jumpers.</i> Two user-adjustable jumpers control the range of trip circuit current required to operate the time overcurrent (51) and instantaneous overcurrent A (50-A) target indicators. Jumper J1 sets the minimum current range for the 50-A target indicator and J2 sets the minimum current range for the 51 target indicator. Two jumper positions are possible: across pins 1 and 2 or across pins 2 and 3. When the jumper is installed across pins 1 & 2, the targets must operate ≥ 2.25 A and must <u>not</u> operate < 900 mA. When the jumper is installed across pins 2 & 3, the targets must operate ≥ 200 mA and must <u>not</u> operate < 80 mA.</p>
B	<p><i>Four Position Slide Switch.</i> This switch assembly, designated SW3, has four independent slide switches designated SW3-1, SW3-2, SW3-3, and SW3-4. Each switch functions as follows:</p> <p>SW3-1 selects the nominal system frequency. The OFF position selects 60 Hz operation and the ON position selects 50 Hz operation.</p> <p>SW3-2 provides an additional time delay for the instantaneous overcurrent A (50-A) element. The ON position provides an additional delay of 100 milliseconds.</p> <p>SW3-3 selects either GE IAC or Westinghouse CO/COM type characteristic curves. The ON position selects the GE IAC type curves (listed in Table 4) and the OFF position selects the Westinghouse CO/COM type curves (listed in Table 5).</p> <p>SW3-4 selects either an instantaneous or integrating time reset characteristic. The ON position selects an integrating reset characteristic and the OFF position selects an instantaneous reset characteristic.</p>
C	<p><i>Instantaneous Overcurrent B Pickup Selector Switches.</i> These two screwdriver-adjusted, rotary switches select the instantaneous overcurrent B (50-B) pickup current setting in amperes.</p> <p>The 50-B pickup switches are accessed on the right side of the draw-out assembly by removing the draw-out assembly from the case.</p> <p>SW9 is a 16-position switch that sets the units portion (<u>#.#</u>) of the 50-B pickup setting in amperes. SW9 setting positions consist of 0 through 9 which correspond to values of 0 to 9 amperes and A through F which correspond to values of 10 to 15 amperes. SW10 is a 10-position switch that sets the tenths portion (<u>#.#</u>) of the 50-B pickup setting in amperes. SW10 setting positions consist of 0 through 9 which correspond to values of 0.0 to 0.9 amperes.</p> <p>The minimum allowable 50-B pickup setting is 1.0 Aac and the maximum allowable 50-B pickup setting is 15.9 Aac. Adjusting the 50-B pickup selector switches while the relay is in service may cause the relay to trip.</p> <p>Example: SW9 position 2 and SW10 position 5 is a setting of 2.5 Aac.</p>

3 • Functional Description

Introduction

This section illustrates and describes the functional capabilities of the BE1-50/51B-241 relay.

Function Block Descriptions

BE1-50/51B-241 function blocks are illustrated in Figure 3-1 and described in the following paragraphs.

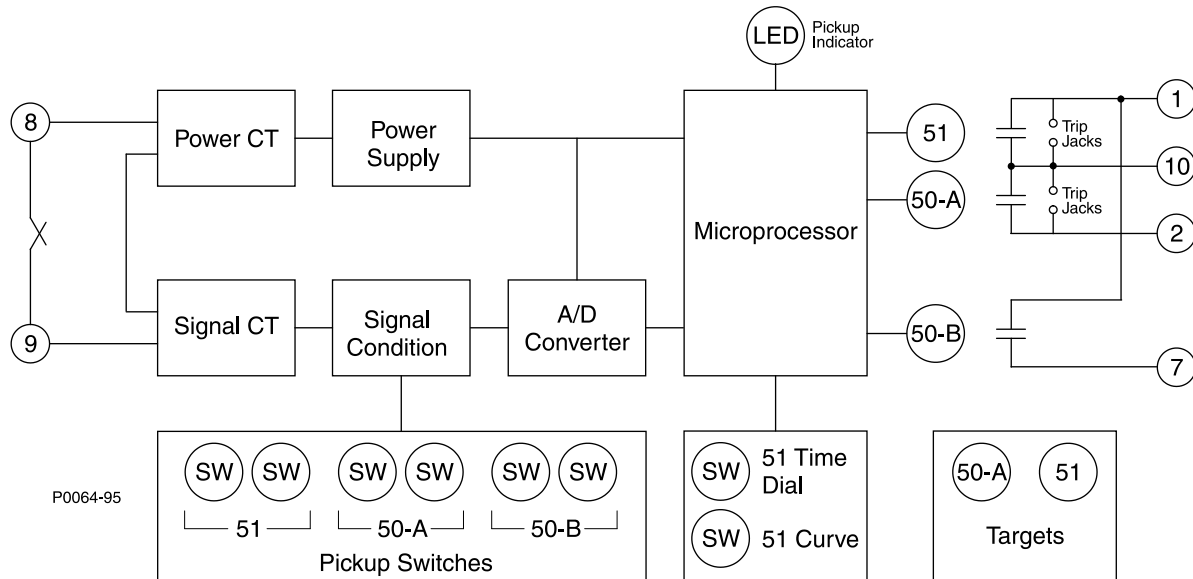

Figure 3-1. Function Block Diagram

Current Sensing Input

Single-phase ac current supplied by a system current transformer (CT) is applied to the BE1-50/51B-241 at terminals 8 and 9. Sensing current is applied to internal power and signal CTs.

Power CT and Power Supply

The output of the power CT is supplied to the power supply which provides rectified and filtered operating power for all relay circuitry. A precision 5 Vdc output of the power supply serves as a reference for automatic calibration.

Signal Conditioning

Current from the signal CT is rectified and applied to three independent sets of scaling resistors controlled by the Time Overcurrent (51), Instantaneous Overcurrent A (50-A), and Instantaneous Overcurrent B (50-B) pickup switches. The analog-to-digital converter receives the analog voltage developed across the scaling resistors and converts it into a digital signal that is supplied to the microprocessor.

Microprocessor

The microprocessor performs program operations based on the sensed current, switch settings, and the internal software program.

When sufficient current is sensed by the relay, the microprocessor is active and executing code, and the Active/Pickup LED is green. When the sensed current decreases below the operating threshold, microprocessor operation is interrupted and the Active/Pickup LED turns off. A watchdog circuit resets the microprocessor program when code execution is interrupted.

Power-off sensing circuits measure the voltage across a capacitor at power-down and power-up. These circuits determine how long power has been removed based on the difference voltage and the circuit's RC time constant. This provides information from the integrating reset function even when power has been entirely removed.

The microprocessor performs the program operations based on the inputs and the internal software program. When the sensed current exceeds the TIME PICKUP setting, the ACTIVE/PICKUP LED turns from green to red. The 50-A/51 contact is closed in accordance with the TIME characteristic equation or if the sensed current exceeds the INST PICKUP setting. Likewise, sensed current exceeding the Instantaneous Overcurrent B Pickup selector switch setting causes the 50-B Trip output contacts to close.

Outputs

Each protective element (time overcurrent (51), instantaneous overcurrent A (50-A), and instantaneous overcurrent B (50-B)) is equipped with a set of normally-open contacts rated for tripping duty. A system circuit breaker controlled by the 51 or 50-A output contacts can be manually tripped by connecting a jumper across the Time Overcurrent Manual Trip jacks or the Instantaneous Overcurrent Manual Trip jacks. (Manual trip jacks are not provided for the system circuit breaker controlled by the 50-B output contacts.) Current flow in a trip circuit is indicated by operation of the corresponding target. The targets will not operate without adequate relay operating power.

Warning!

Trip circuit voltage is present at the front panel trip jacks. When shorting the trip jacks, use insulated jumpers to avoid contact with these voltages.

Target Indicators

Gravity-latched, manually-reset, current-operated target indicators are provided for the time overcurrent (51) trip output and the instantaneous overcurrent A (50-A) trip output. A target indicator is not provided for the 50-B trip output. The level of trip circuit current required to operate each target is individually controlled by a circuit board jumper. The minimum operating current range can be set for 80 to 200 milliamperes or 0.9 to 2.25 amperes. See the *Controls and Indicators* chapter for jumper locations and function assignments.

4 • Installation

General

When not shipped as part of a control or switchgear panel, the relays are shipped in sturdy cartons to prevent damage during transit. Immediately upon receipt of a relay, check the model and part number against the requisition and packing list to see that they agree. Visually inspect the relay for damage that may have occurred during shipment. If there is evidence of damage, immediately file a claim with the carrier and notify the Regional Sales Office, or contact the Sales Representative at Basler Electric, Highland, Illinois.

Proper operation of the relay may be confirmed by performing the operational test procedures of the *Testing* chapter. If the relay will not be installed immediately, store the relay in its original shipping carton in a moisture- and dust-free environment.

Factory Settings

BE1-50/51B-241 jumpers and internal switch SW3 are configured at the factory as follows:

- SW3-1: OFF (60 hertz operation).
- SW3-2: OFF (0.0 additional fixed delay for the instantaneous element).
- SW3-3: OFF (Westinghouse CO/COM type characteristic curves).
- SW3-4: ON (Integrating reset characteristics).
- J1 pins 2-3: 50-A minimum target operating current of 80 to 200 mA
- J2 pins 2-3: 51 minimum target operating current of 80 to 200 mA

Installation

Note

If replacing a CO relay manufactured prior to 1966, please contact Basler Electric to verify compatibility.

Select the desired relay settings before putting the relay into service. Changing pickup current settings while the relay is in service may cause tripping. Perform the following steps to install the BE1-50/51B-241 relay.

1. Select the desired relay settings on your new BE1-50/51B-241 relay.
2. Remove the existing Westinghouse relay cradle.
3. Insert the new relay cradle and close the cradle latches locking the relay into the case.
4. Install the cover by positioning the interlocking bracket at the top of the new Basler Electric cover into the mating receptacle at the top of the cover adapter plate. Secure the captive fastener at the bottom of the cover.

Connections

Typical ac connections are shown in Figure 4-1. Typical dc connections are shown in Figure 4-2.

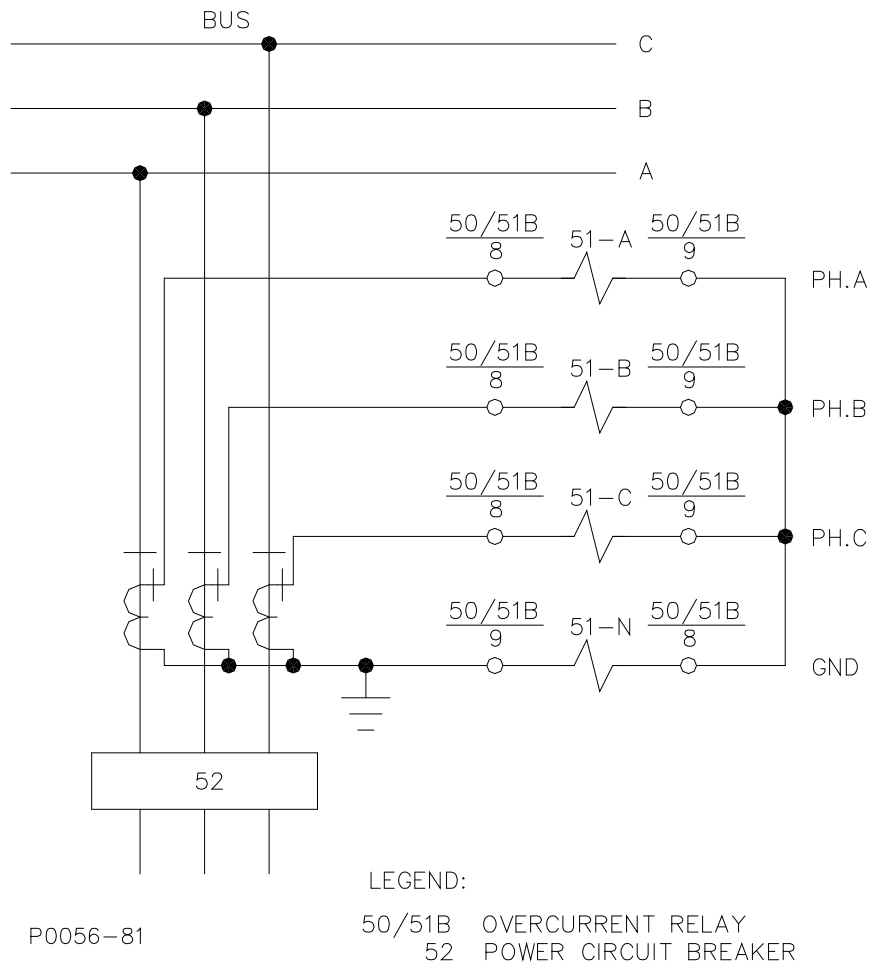

P0056-81

Figure 4-1. Typical AC Connections

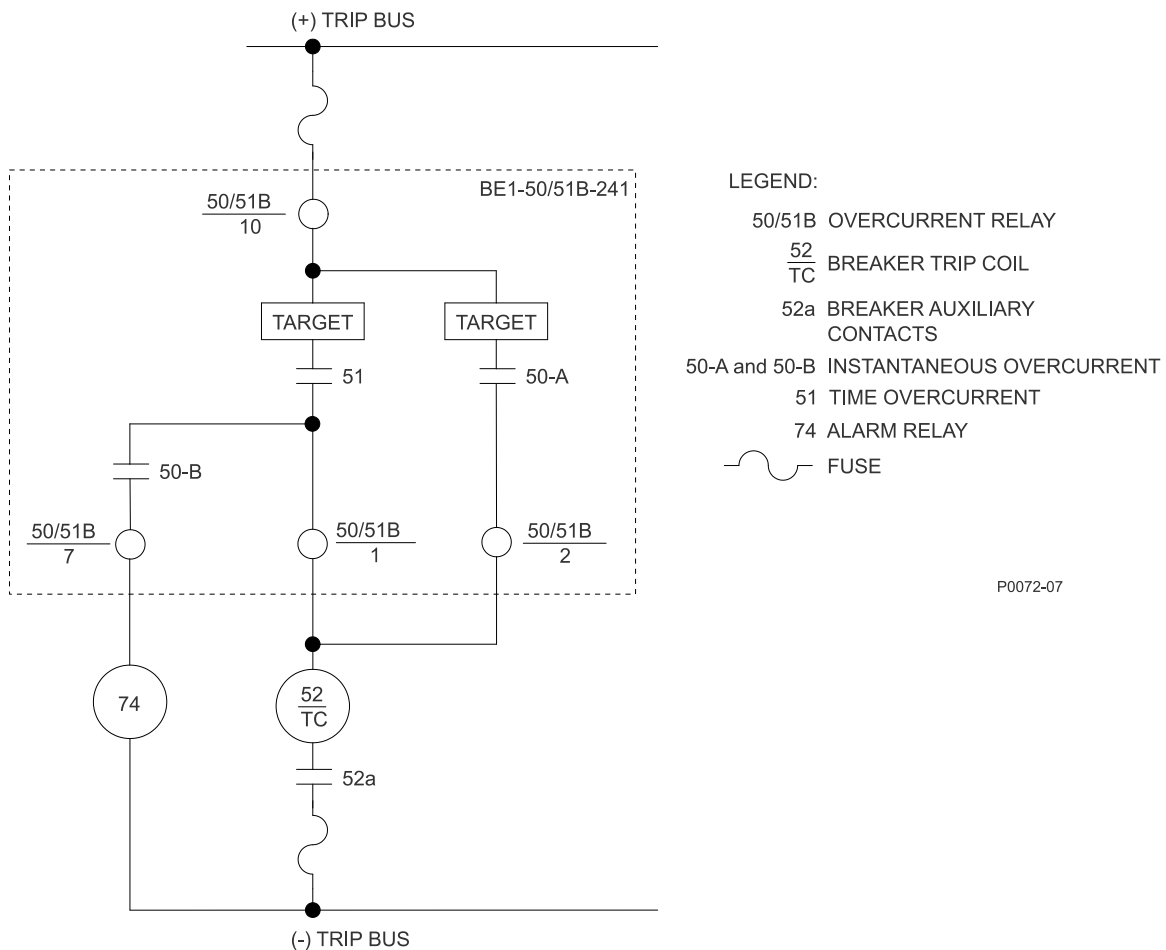

Figure 4-2. Typical DC Connections

Application Coordination

In a typical application coordination scheme, a BE1-50/51B-241 is used to provide motor protection. An electromechanical overcurrent relay with extremely inverse timing provides protection for the transformer and bus. To improve coordination with the electromechanical relay, the BE1-50/51B-241 is configured with the following settings:

- Integrating reset enabled (SW3-4 ON)
- Westinghouse CO/COM type curves selected (SW3-3 OFF)

The feeder reclosing relay is set for two reclose attempts at 3 and 15 seconds after the initial trip. If a permanent fault occurs (magnitude 10 times pickup), calculate the feeder breaker trip time for each of the three operations. Refer to the *Characteristic Curves* chapter for the characteristic curve constants and definition of the terms used in the following time characteristic curve equations.

From the time characteristic curve equation:

$$\begin{aligned}
 T_T &= \frac{AD}{M^N - C} + BD + K \\
 &= \frac{7.7624 \times 2}{10^{2.0938} - 1} + (0.02758 \times 2) + 0.028 \\
 &= 0.209 \text{ seconds}
 \end{aligned}$$

From the reset characteristic curve equation:

$$T_R = \frac{RD}{M^2 - 1}$$

M equals 0 if current goes to zero. A negative result indicates reset time.

$$= \frac{7.75 \times 2}{0^2 - 1} = -15.5 \text{ seconds}$$

Result: Full trip = 0.209 seconds and full reset = 15.5 seconds if current goes to zero.

In Figure 4-3:

T_A = 0.209 seconds (relay was at reset)

T_B = value < T_A because rewind has not gone to zero

T_C = value < T_A because rewind has not gone to zero

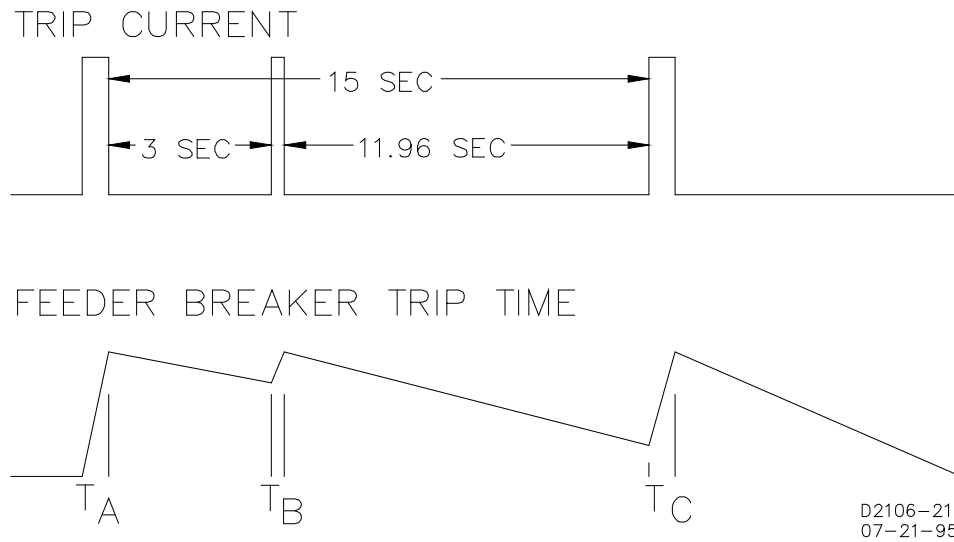

Figure 4-3. Coordination Timing Diagram

Maintenance

A BE1-50/51B-241 relay requires no preventive maintenance other than periodic checking of relay connections to make sure that they are clean and tight. If the relay fails to function properly, contact Basler Electric Technical Sales Support.

Storage

This device contains long-life aluminum electrolytic capacitors. For devices that are not in service (spares in storage), the life of these capacitors can be maximized by energizing the device for 30 minutes once per year.

5 • Testing

Introduction

Proper relay operation may be confirmed by performing the test procedures in this chapter.

Dielectric Test

In accordance with IEC 255-5 and IEEE C37.90-2005, one-minute dielectric (high potential) tests may be performed as follows:

- All circuits to ground: 2,828 Vdc or 2,000 Vac
- Input to output circuits: 2,828 Vdc or 2,000 Vac

Output contacts are surge protected.

Test Procedures

The following test procedures verify operation of the BE1-50/51B-241 relay. The test setups illustrated in Figures 10 through 12 are intended primarily as an illustration of the principals involved. Other test equipment known to be capable of testing with the stated and implied tolerances (including equipment designed specifically for testing protective relays) may be used.

The minimum test equipment requirements are:

- Current source with a range of 0 to 20 Aac (sensing input current)
- AC or DC voltage source (target operation)
- Timer or counter

Note

To ensure proper timing during testing, remove the current from the relay for R times D seconds. (Refer to the *Characteristic Curves* chapter for definitions of R and D.

When testing TIME overcurrent functions, INST PICKUP settings of 00 will affect the calibration of the TIME functions. TIME PICKUP settings of 00 also affect INST functions.

Observe all applicable electrostatic discharge (ESD) precautions when handling the relay assembly.

Time Overcurrent (51) Pickup

1. Connect and configure the relay for 51 pickup testing:
 - a. Connect the test setup shown in Figure 5-1.
 - b. Set circuit board switch SW3 as follows:
 - a. SW3-1 = ON for 50 Hz operation or OFF for 60 Hz operation
 - b. SW3-2 = OFF (no additional time delay for the 50-A element)
 - c. SW3-3 = ON (Westinghouse CO/COM type characteristic curves)
 - d. SW3-4 = ON (integrating reset characteristic)
 - c. Set the TIME DIAL to 0.0.
 - d. Set CURVE to S.
 - e. Set TIME PICKUP to 0.5.

- f. Set INST PICKUP (50-A) to 90.
- g. Set INST PICKUP (50-B) (accessed at the top side of the assembly) to F0 (15.0 Aac).
2. Apply and increase current to terminals 8 and 9 until the Active/Pickup LED turns red. The applied current should be no greater than 0.55 Aac.
3. Decrease the applied current until the Active/Pickup LED changes from red to green and then off.
4. Set TIME PICKUP to 2.2.
5. Slowly increase current to terminals 8 and 9 until the Active/Pickup LED turns red. The applied current should be between 2.131 and 2.269 Aac.
6. Reduce the applied current to zero.

Time Dial

1. Connect and configure the relay for time dial testing:
 - a. Connect the test setup shown in Figure 5-1.
 - b. Set circuit board switch SW3 as follows:
 - SW3-1 = ON for 50 Hz operation or OFF for 60 Hz operation
 - SW3-2 = OFF (no additional time delay for the 50-A element)
 - SW3-3 = ON (Westinghouse CO/COM type characteristic curves)
 - SW3-4 = ON (integrating reset characteristic)
 - c. Set TIME DIAL to 4.5.
 - d. Set CURVE to S.
 - e. Set TIME PICKUP to 1.0.
 - f. Set INST PICKUP (50-A) to 90.
 - g. Set INST PICKUP (50-B) (accessed at the top side of the assembly) to F0 (15.0 Aac).
2. Prepare to apply 1.5 Aac to terminals 8 and 9 and record the elapsed time from when current is applied until the 51 output contacts close.
3. Apply the current (step from 0 to 1.5 Aac) and record the elapsed time. The elapsed time should be between 0.345 and 0.424 seconds. (This tolerance is greater than $\pm 2\%$ because it is the accumulation of both pickup and timing tolerances.)
4. Remove the input current.

Integrating Reset

1. Connect and configure the relay for integrating reset testing.
 - a. Connect the test setup shown in Figure 5-1.
 - b. Set circuit board switch SW3 as follows:
 - c. SW3-1 = ON for 50 Hz operation or OFF for 60 Hz operation
 - d. SW3-2 = OFF (no additional time delay for the 50-A element)
 - e. SW3-3 = ON (Westinghouse CO/COM type characteristic curves)
 - f. SW3-4 = ON (integrating reset characteristic)
 - g. Set TIME DIAL to 9.9
 - h. Set CURVE to V.
 - i. Set TIME PICKUP to 1.0.
 - j. Set INST PICKUP (50-A) to 90.
 - k. Set INST PICKUP (50-B) (accessed at the top side of the assembly) to F0 (15.0 Aac).

2. Apply 4.0 Aac to terminals 8 and 9. After the unit trips, remove the applied current for 29 ± 0.25 seconds, then reapply the current (4.0 Aac). Note the elapsed time from the reapplication of current to the second trip. The elapsed time should be 2.08 ± 0.4 seconds.

Instantaneous Overcurrent A (50-A) Pickup

1. Connect and configure the relay for 50-A pickup testing:
 - a. Connect the test setup shown in Figure 5-1.
 - b. Set circuit board switch SW3 as follows:
 SW3-1 = ON for 50 Hz operation or OFF for 60 Hz operation
 SW3-2 = OFF (no additional time delay for the 50-A element)
 SW3-3 = ON (Westinghouse CO/COM type characteristic curves)
 SW3-4 = ON (integrating reset characteristic)
 - c. Set TIME DIAL to 0.0.
 - d. Set CURVE to S.
 - e. Set TIME PICKUP to 15.0.
 - f. Set INST PICKUP (50-A) to 02.
 - g. Set INST PICKUP (50-B) (accessed at the top side of the assembly) to F0 (15.0 Aac).
2. Apply and slowly increase current to terminals 8 and 9 until the 50-A output contacts close. The applied current should be between 1.935 and 2.065 Aac.
3. Decrease the applied current until the 50-A output contacts open.
4. Set INST PICKUP (50-A) to 08.
5. Slowly increase the current applied to terminals 8 and 9 until the 50-A output contacts close. The applied current should be between 7.815 and 8.185 Aac.
6. Reduce the applied current to zero.

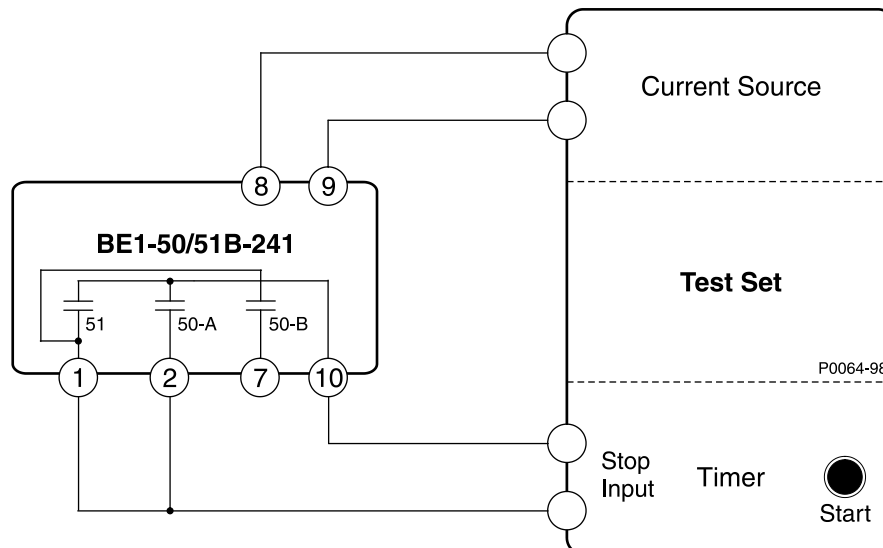

Figure 5-1. 51 Pickup, Time Dial, Integrating Reset, and 50-A Pickup Test Setup

Instantaneous Overcurrent B (50-B) Pickup

1. Connect and configure the relay for 50-B pickup testing:
 - a. Connect the test setup shown in Figure 5-2.
 - b. Set circuit board switch SW3 as follows:

SW3-1 = ON for 50 Hz operation or OFF for 60 Hz operation
 SW3-2 = OFF (no additional time delay for the 50-A element)
 SW3-3 = ON (Westinghouse CO/COM type characteristic curves)
 SW3-4 = ON (integrating reset characteristic)

- c. Set TIME DIAL to 0.0.
 - d. Set CURVE to S.
 - e. Set TIME PICKUP to 15.0.
 - f. Set INST PICKUP (50-A) to 90.
 - g. Set INST PICKUP (50-B) (accessed at the top side of the assembly) to 20 (2.0 Aac).
2. Apply and slowly increase current to terminals 8 and 9 until the 50-B output contacts close. The applied current should be between 1.935 and 2.065 Aac.
 3. Decrease the applied current until the 50-B output contacts open.
 4. Set INST PICKUP (50-B) to 80 (8.0 Aac).
 5. Slowly increase the current applied to terminals 8 and 9 until the 50-B output contacts close. The applied current should be between 7.815 and 8.185 Aac.
 6. Reduce the applied current to zero.

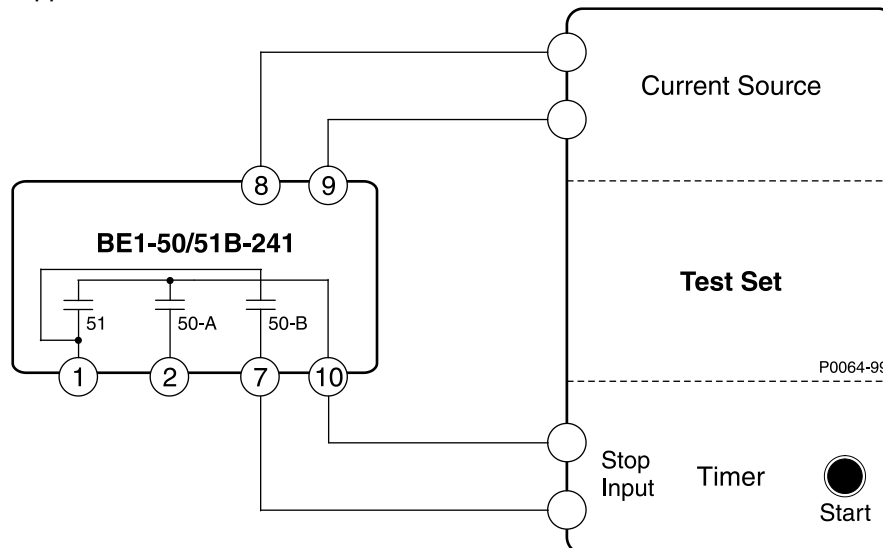

Figure 5-2. 50-B Pickup Test Setup

Target Indicators

1. Connect and configure the relay for target indicator testing:
 - a. Connect the test setup shown in Figure 5-3.
 - b. Set circuit board switch SW3 as follows:
 SW3-1 = ON for 50 Hz operation or OFF for 60 Hz operation
 SW3-2 = OFF (no additional time delay for the 50-A element)
 SW3-3 = ON (Westinghouse CO/COM type characteristic curves)
 SW3-4 = ON (integrating reset characteristic)
 - c. Set TIME DIAL to 0.0.
 - d. Set CURVE to S.
 - e. Set TIME PICKUP to 1.0.
 - f. Set INST PICKUP (50-A) to 90.

- g. Set INST PICKUP (50-B) (accessed at the top side of the assembly) to F0 (15.0 Aac).
2. Apply 2 Aac to terminals 8 and 9 to trip the 51 relay output.
3. Slowly increase the voltage source to provide target current and verify that the Time target operates at the level of current determined by the Target Operating Current Jumpers.
4. The Target Operating Current Jumpers are located on the circuit board and identified as J1 and J2. J1 sets the minimum current range for the 50-A target and J2 sets the minimum current range for the 51 target. A jumper installed across pins 1 and 2 gives a minimum operating current of 0.9 to 2.25 A. A jumper installed across pins 2 and 3 gives a minimum operating current of 80 to 200 mA.
5. Remove the target and sensing current and reset the target.
6. Set TIME PICKUP to 9.0.
7. Set INST PICKUP (50-A) to 01.
8. Apply 2 Aac to terminals 8 and 9 to trip the 50-A relay output.
9. Slowly increase the voltage source to provide target current and verify that the Instantaneous target operates at the level of current determined by the Target Operating Current Jumpers.
10. Remove the target and sensing current and reset the target.

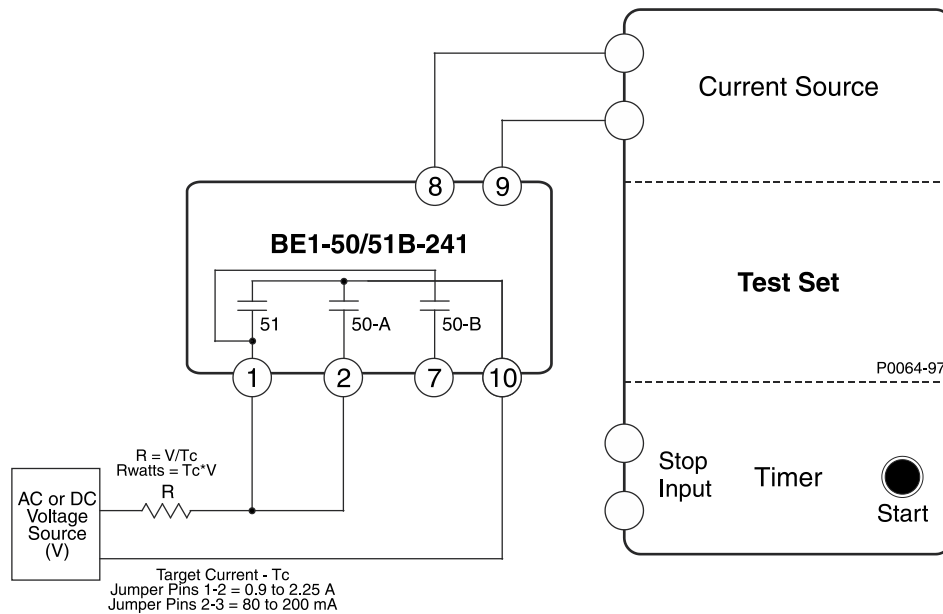

Figure 5-3. Target Indicator Test Setup

Manual Trip

1. Configure the relay for manual trip testing:
 - a. Connect the test setup as shown in Figure 10.
 - b. Set circuit board switch SW3 as follows:
 - SW3-1 = ON for 50 Hz operation or OFF for 60 Hz operation
 - SW3-2 = OFF (no additional time delay for the 50-A element)
 - SW3-3 = ON (Westinghouse CO/COM type characteristic curves)
 - SW3-4 = ON (integrating reset characteristic)
 - c. Set TIME DIAL to 0.0
 - d. Set CURVE to S.
 - e. Set TIME PICKUP to 1.0.

- f. Set INST PICKUP (50-A) to 90.
- g. Set INST PICKUP (50-B) (accessed at the top side of the assembly) to 20 (2.0 Aac).

Warning!

Trip circuit voltage is present at the front panel test points. When shorting the test points, use insulated jumpers to avoid contact with these voltages.

- 2. Apply 0.9 Aac to terminals 8 and 9 (0.9 Aac provides relay operating power but is below the pickup threshold.)
- 3. Connect a jumper to the Time Overcurrent Manual Trip jacks. Verify that the stop input of the test set timer recognizes a 51 contact closure.
- 4. Remove the jumper and the current applied at relay terminals 8 and 9.
- 5. Apply 0.9 Aac to terminals 8 and 9.
- 6. Connect a jumper to the Instantaneous Overcurrent Manual Trip jacks. Verify that the stop input of the test set timer recognizes a 50-A contact closure
- 7. Remove the jumper and the current applied to relay terminals 8 and 9.
- 8. Reset targets.

6 • Characteristic Curves

Introduction

This chapter describes and defines the instantaneous overcurrent, time overcurrent, and integrating time reset characteristics of the BE1-50/51B-241 relay.

Instantaneous Overcurrent Characteristics

Timing

The instantaneous characteristic curves of the BE1-50/51B-241 relay are similar to standard electromechanical instantaneous units. However, the time to trip for applications where the initial sensing current is less than 400 mA may be slightly longer. This may occur on a very lightly loaded circuit or when the relay is providing ground protection and is connected to measure neutral current. Figure 6-1 shows the instantaneous characteristic curves for the maximum time to trip.

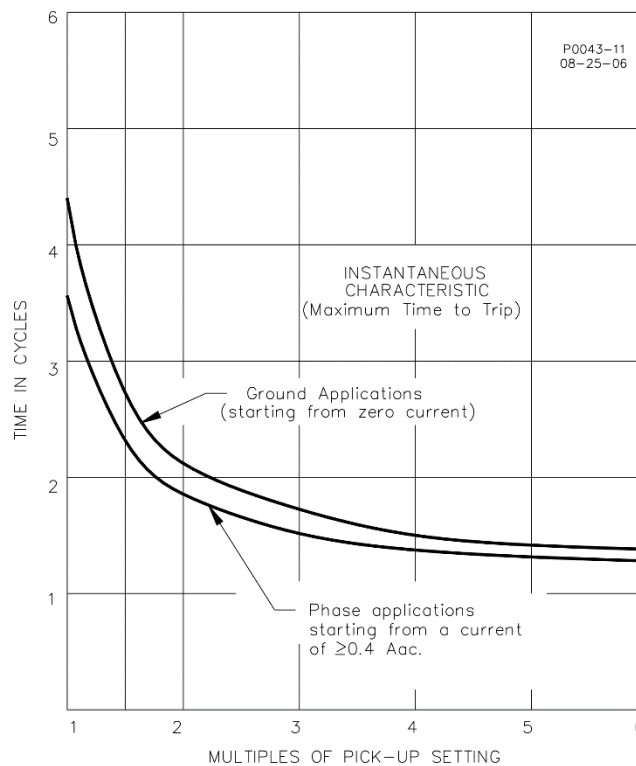

Figure 6-1. Instantaneous Characteristic Curves

The delay of the Instantaneous A (50-A) element can be set for no intentional delay (switch SW3-2 open) or an additional delay of 100 milliseconds (SW3-2 closed). Figure 5 illustrates the location of SW3. The time delay of the 50-B element is not switch-selectable and is fixed at no intentional delay.

Pickup

The instantaneous elements of the BE1-50/51B-241 relay may be set lower than the instantaneous element in Westinghouse CO/COM relays and still have the same reach. This is because the BE1-50/51B-241 instantaneous elements effectively eliminate the fault current transient overreach components. When setting the BE1-50/51B-241 instantaneous elements, calculate the symmetrical value without any adder for transient overreach.

Time Overcurrent Characteristics

Nine inverse time functions and one fixed (definite) time function can be selected at the front panel. Curve types are identified by a letter designator. Available curve types are short inverse (S), long inverse (L), definite time (D), moderately inverse (M), inverse (I), very inverse (V), extremely inverse (E), BS142 inverse, (B), and BS142 extremely inverse (C).

Inverse Time Functions

Characteristic curves for the inverse and definite time functions are defined by the following equation:

$$T_T = \frac{AD}{M^N - C} + BD + K$$

Where: T_T = time to trip in seconds
 D = time dial setting
 M = multiple of pickup setting
 A, B, C, N, K = constants for the particular curve

Characteristic Curve Groups

Either GE IAC or Westinghouse CO/COM characteristic curve groups are selected through switch SW3-3. (Refer to Figure 5 for the location of SW3.)

Characteristic Curve Constants

Table 6-1 and Table 6-2 list the time characteristic curve constants used by the relay. Constants have been selected to conform to the characteristics of electromechanical relays over a range of pickup multiples from 1.3 to 40. Values of the constants are provided for use in PC relay setting applications. Timing accuracy is ± 1 cycle $\pm 2\%$ of time to trip.

Table 6-1. Time Characteristic Curve Constants with Switch SW3-3 Open (Off)

Curve Type	Similar To	Figure Number	Constants					
			A	B	C	N	K	R
BE								
S	CO-2	A-2	0.2663	0.03393	1.000	1.2969	0.028	0.500
L	CO/COM-5	A-3	5.6143	2.18592	1.000	1.0000	0.028	15.750
D	CO/COM-6	A-4	0.4794	0.21359	1.000	1.5625	0.028	0.875
M	CO/COM-7	A-5	0.3022	0.12840	1.000	0.5000	0.028	1.750
I	CO/COM-8	A-6	8.9341	0.17966	1.000	2.0938	0.028	9.000
V	CO/COM-9	A-7	5.4678	0.10814	1.000	2.0469	0.028	5.500
E	CO/COM-11	A-8	7.7624	0.02758	1.000	2.0938	0.028	7.750
B	BS142-B*	A-9	1.4636	0.00000	1.000	1.0469	0.028	3.250
C	BS142-C*	A-10	8.2506	0.00000	1.000	2.0469	0.028	8.000
F	None†	None	0.0000	1.00000	0.000	0.0000	0.000	1.000

* Curves B and C are defined in British Standard BS142 and IEC 255-4 (International Electrotechnical Commission).

† Fixed time from 0.1 to 9.9 seconds.

Table 6-2. Time Characteristic Curve Constants with Switch SW3-3 Closed (On)

Curve Type	Similar To	Figure Number	Constants					
			A	B	C	N	K	R
BE								
S	IAC 55	A-11	0.0286	0.0208	1.000	0.9844	0.028	0.0940
L	IAC 66	A-12	2.3955	0.00002	1.000	0.3125	0.028	7.8001
D	CO/COM-6	A-4	0.4797	0.21359	1.000	1.5625	0.028	0.8750
M	CO/COM-7	A-5	0.3022	0.12840	1.000	0.5000	0.028	1.7500
I	IAC 51	A-13	0.2747	0.1042	1.000	0.4375	0.028	0.8868
V	IAC 53	A-14	4.4309	0.0991	1.000	1.9531	0.028	5.8231
E	IAC 77	A-15	4.9883	0.0129	1.000	2.0469	0.028	4.7742
B	BS142-B*	A-9	1.4636	0.00000	1.000	1.0469	0.028	3.2500
C	BS142-C*	A-10	8.2506	0.00000	1.000	2.0469	0.028	8.0000
F	None†	None	0.0000	1.00000	0.000	0.0000	0.000	1.0000

* Curves B and C are defined in British Standard BS142 and IEC 255-4 (International Electrotechnical Commission).

† Fixed time from 0.1 to 9.9 seconds.

Characteristic Curves

Figure 6-2 through Figure 6-15 illustrate the BE1-50/51B-241 time overcurrent characteristic curves.

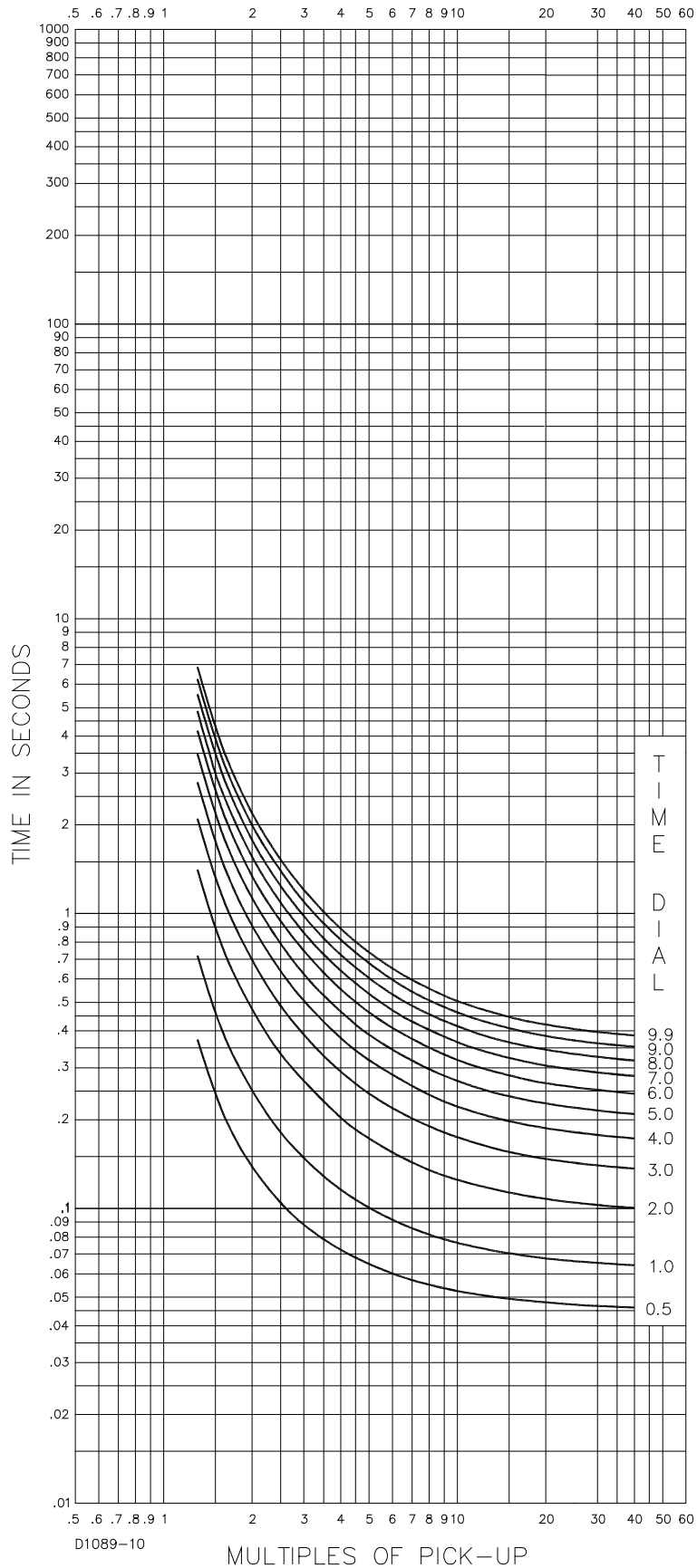

Figure 6-2. Short Inverse (S) Time Characteristic Curve (SW3-3 Off, Similar to CO-2)

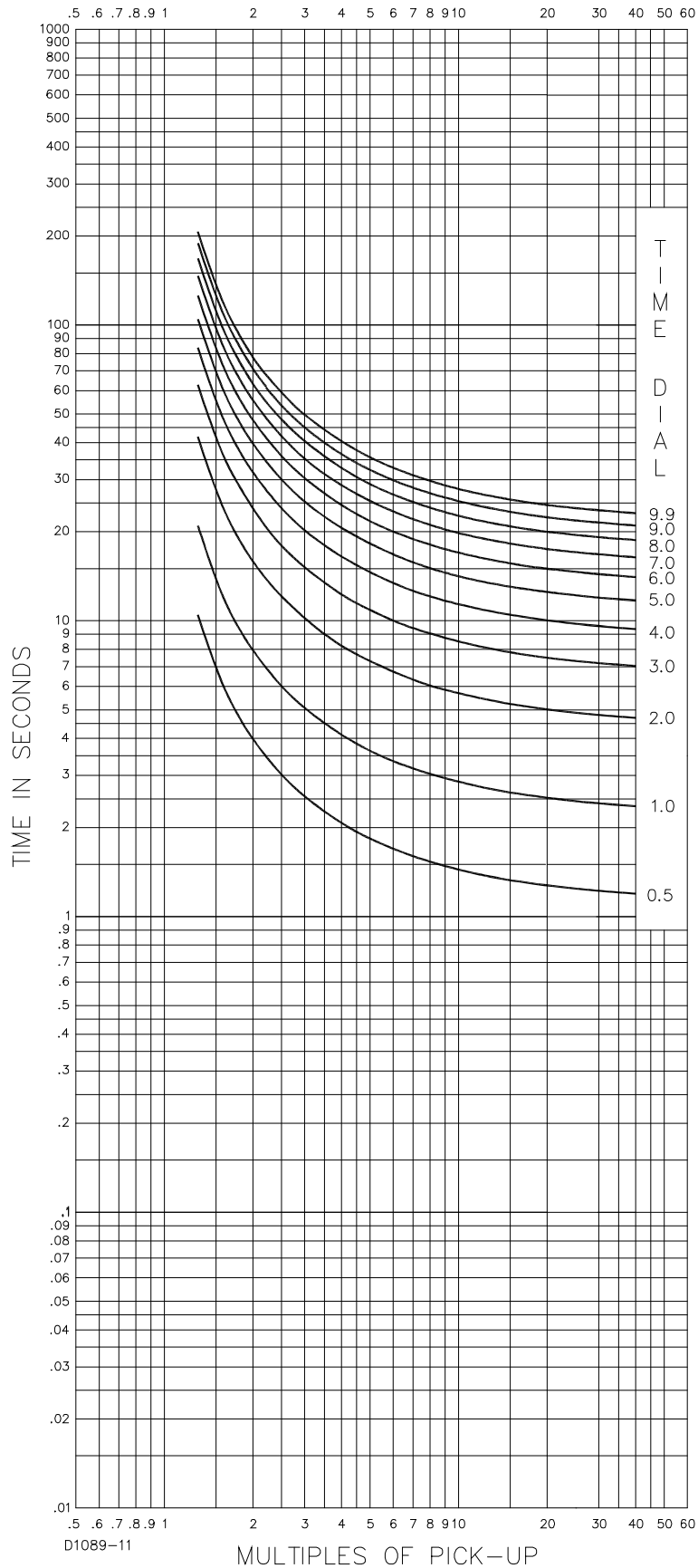

Figure 6-3. Long Inverse (L) Time Characteristic Curve (SW3-3 Off, Similar to CO/COM-5)

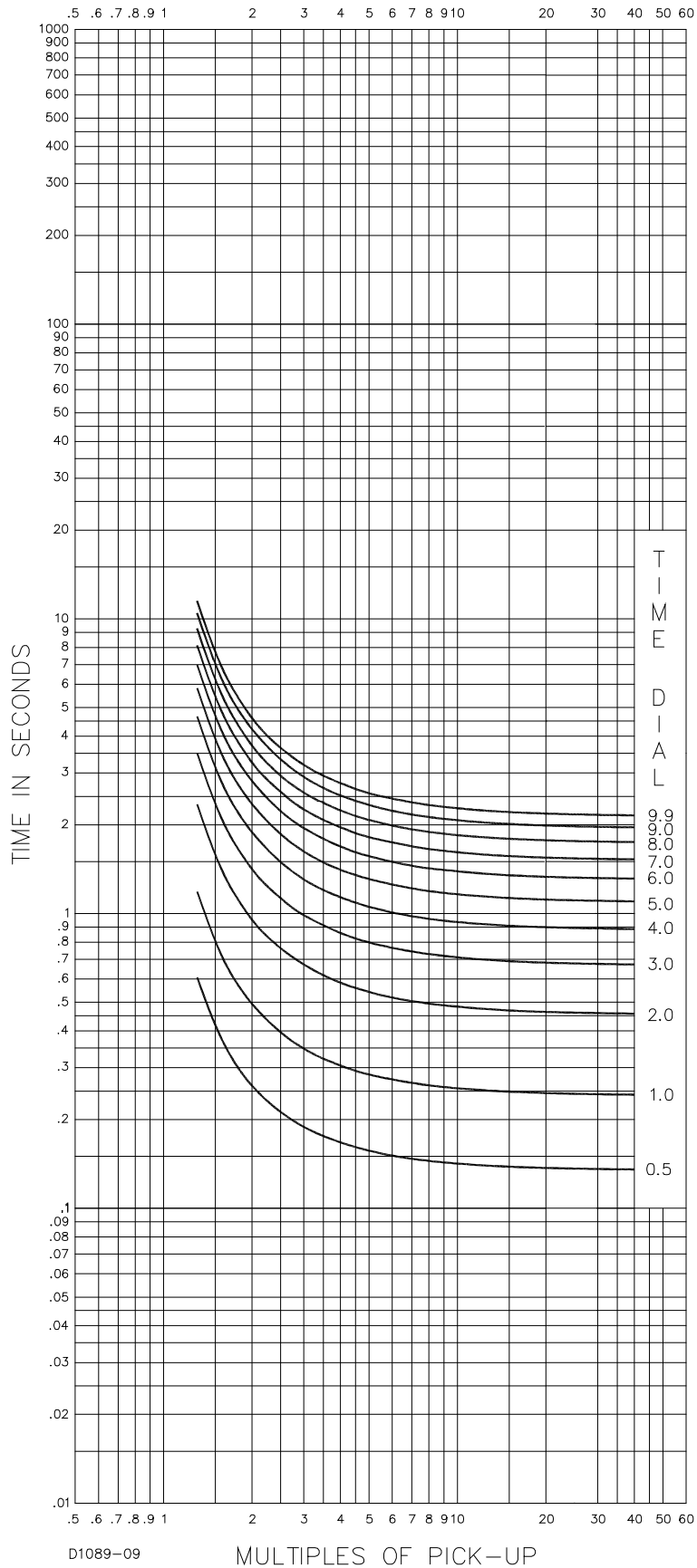

Figure 6-4. Definite Time (D) Time Characteristic Curve (Similar to CO/COM-6)

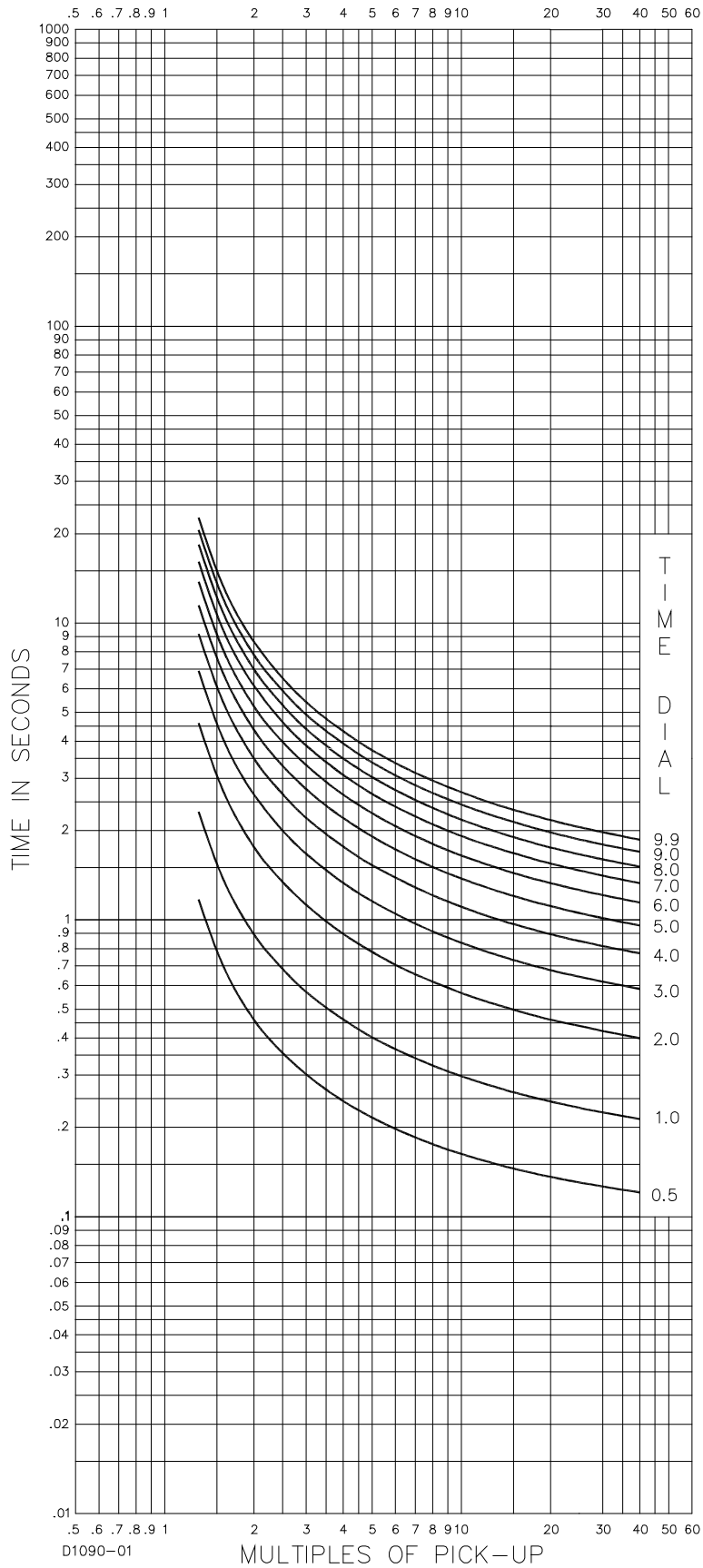

Figure 6-5. Moderately Inverse (M) Time Characteristic Curve (Similar to CO/COM-7)

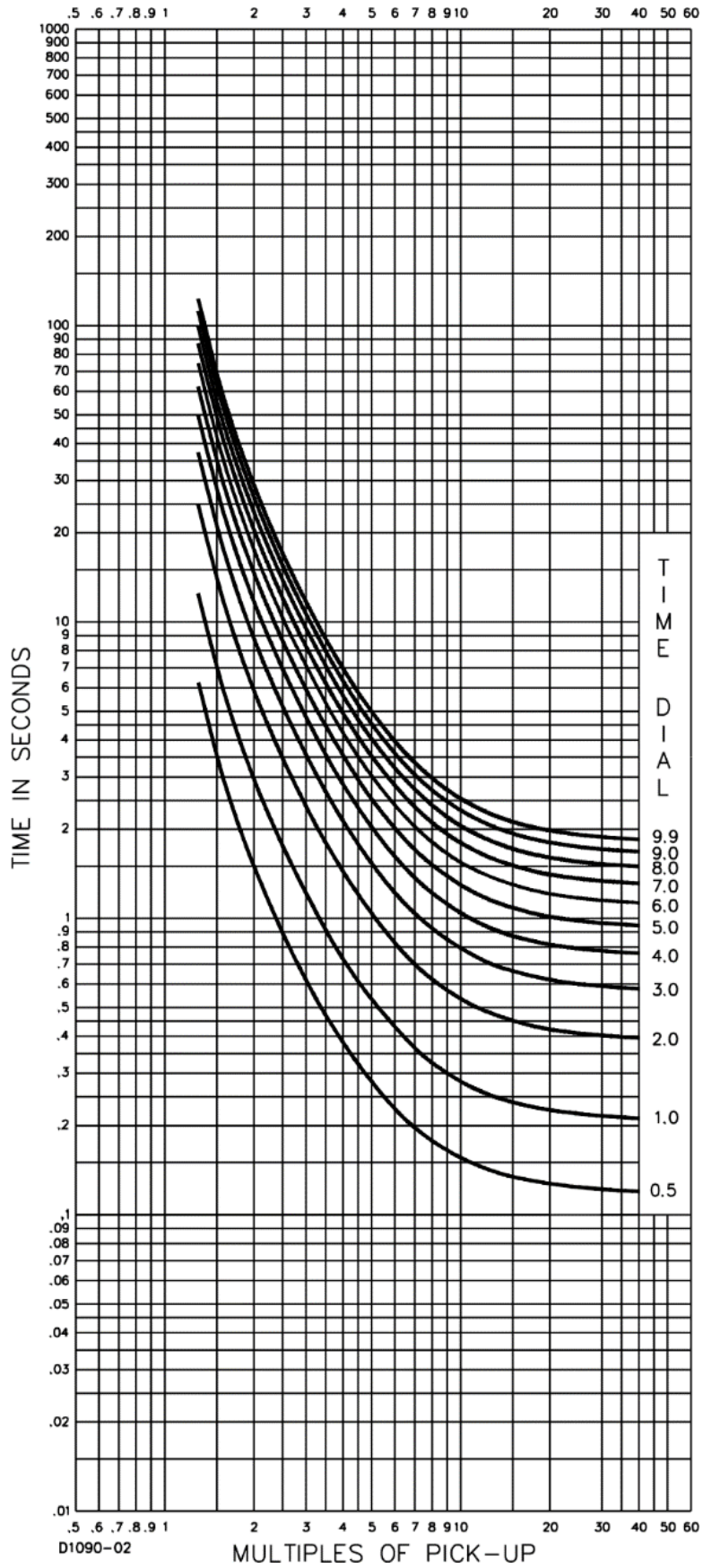

Figure 6-6. Inverse (I) Time Characteristic Curve (SW3-3 Off, Similar to CO/COM-8)

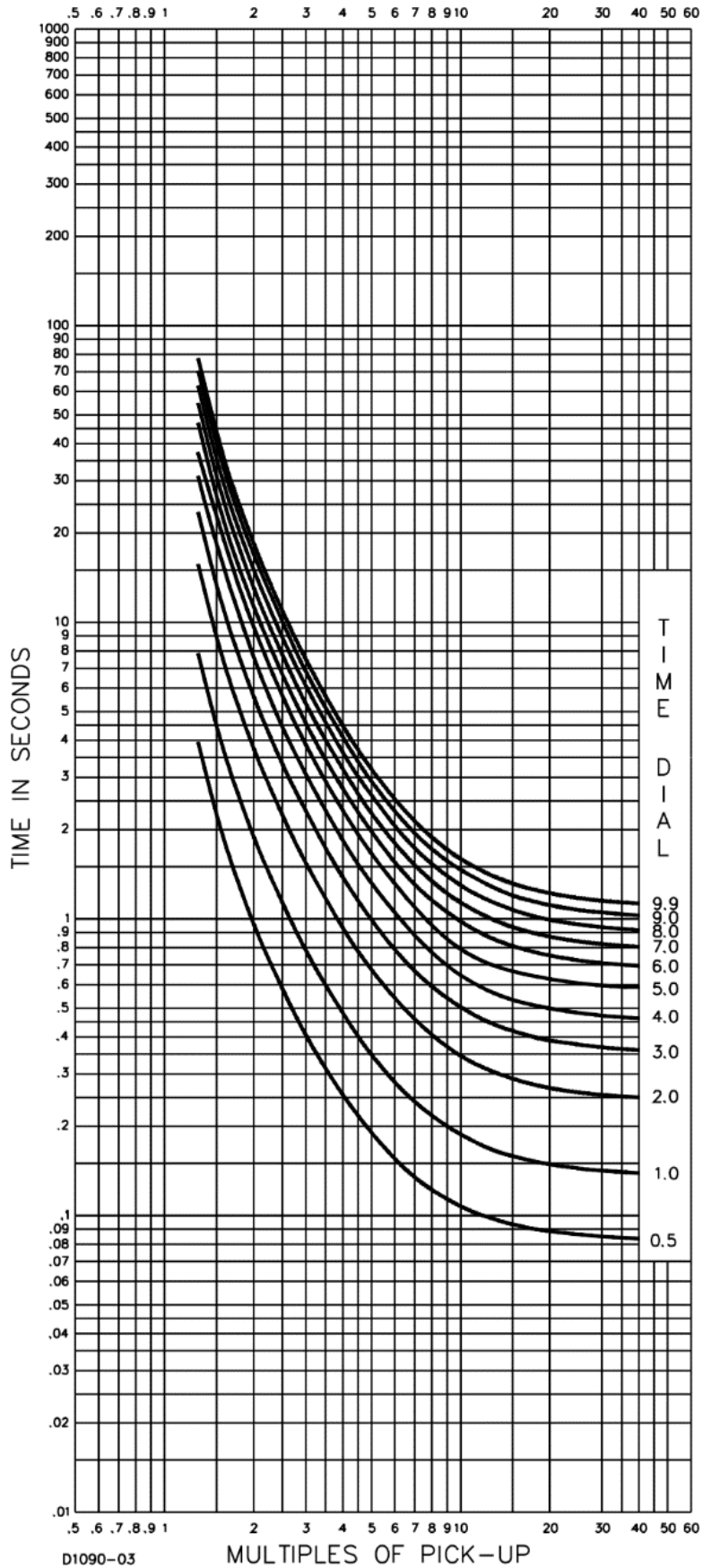

Figure 6-7. Very Inverse (V) Time Characteristic Curve (SW3-3 Off, Similar to CO/COM-9)

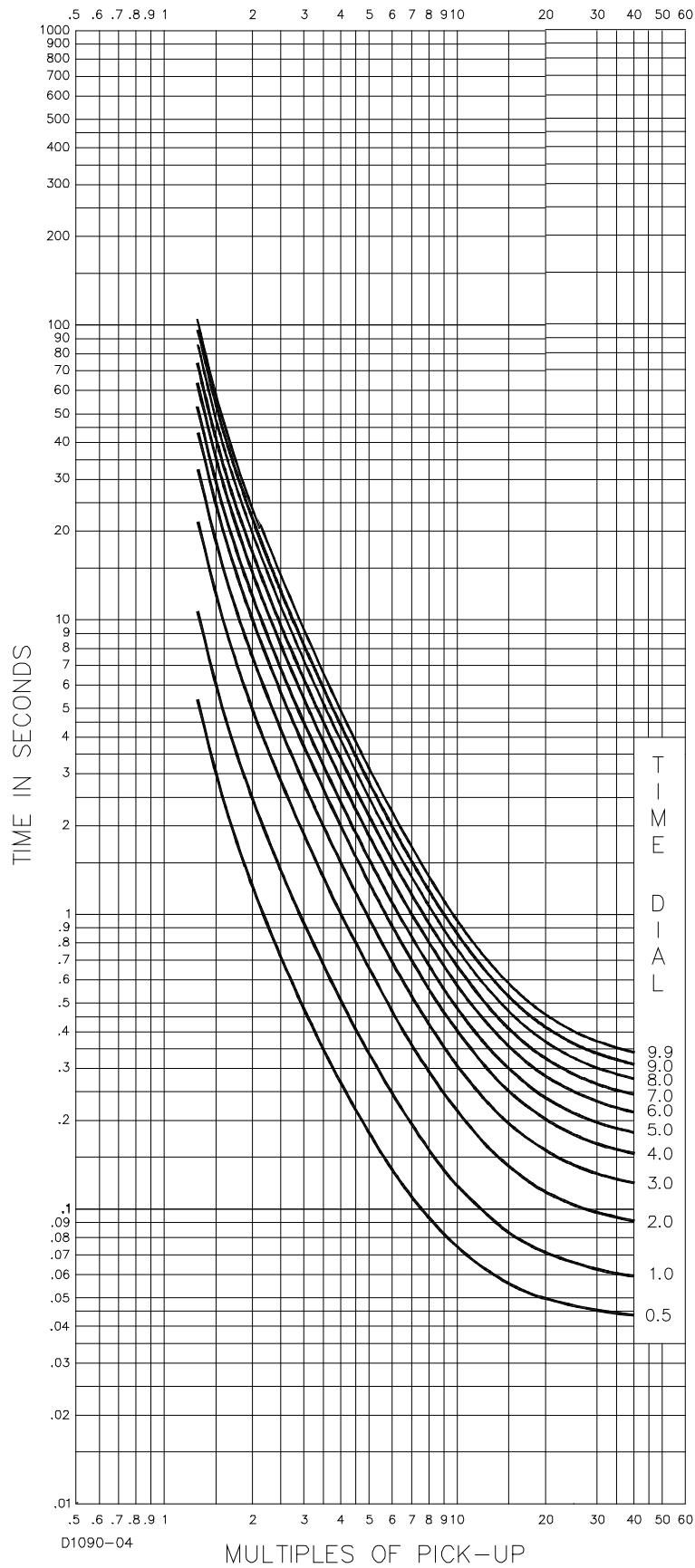

Figure 6-8. Extremely Inverse (E) Time Characteristic Curve (SW3-3 Off, Similar to CO/COM-11)

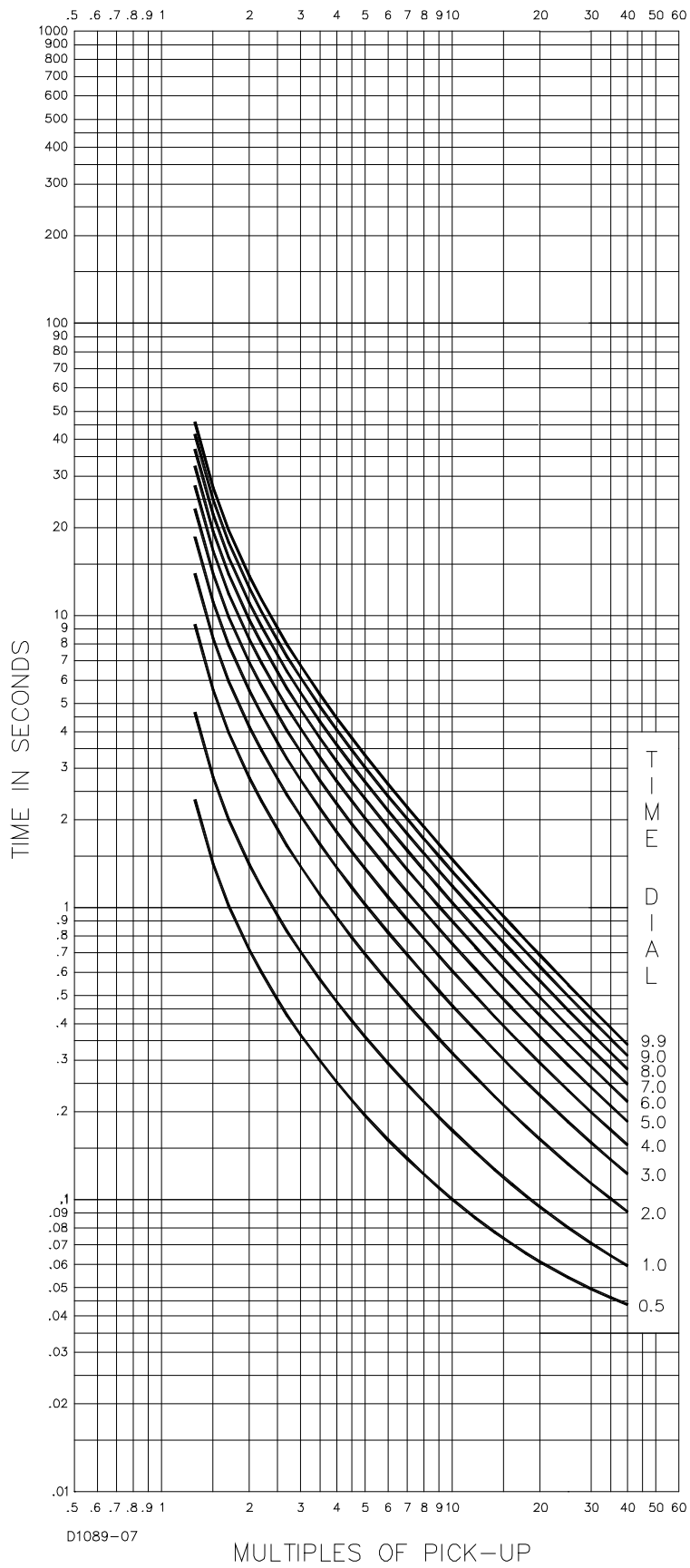

Figure 6-9. BS142 Very Inverse (BS142-B) Time Characteristic Curve

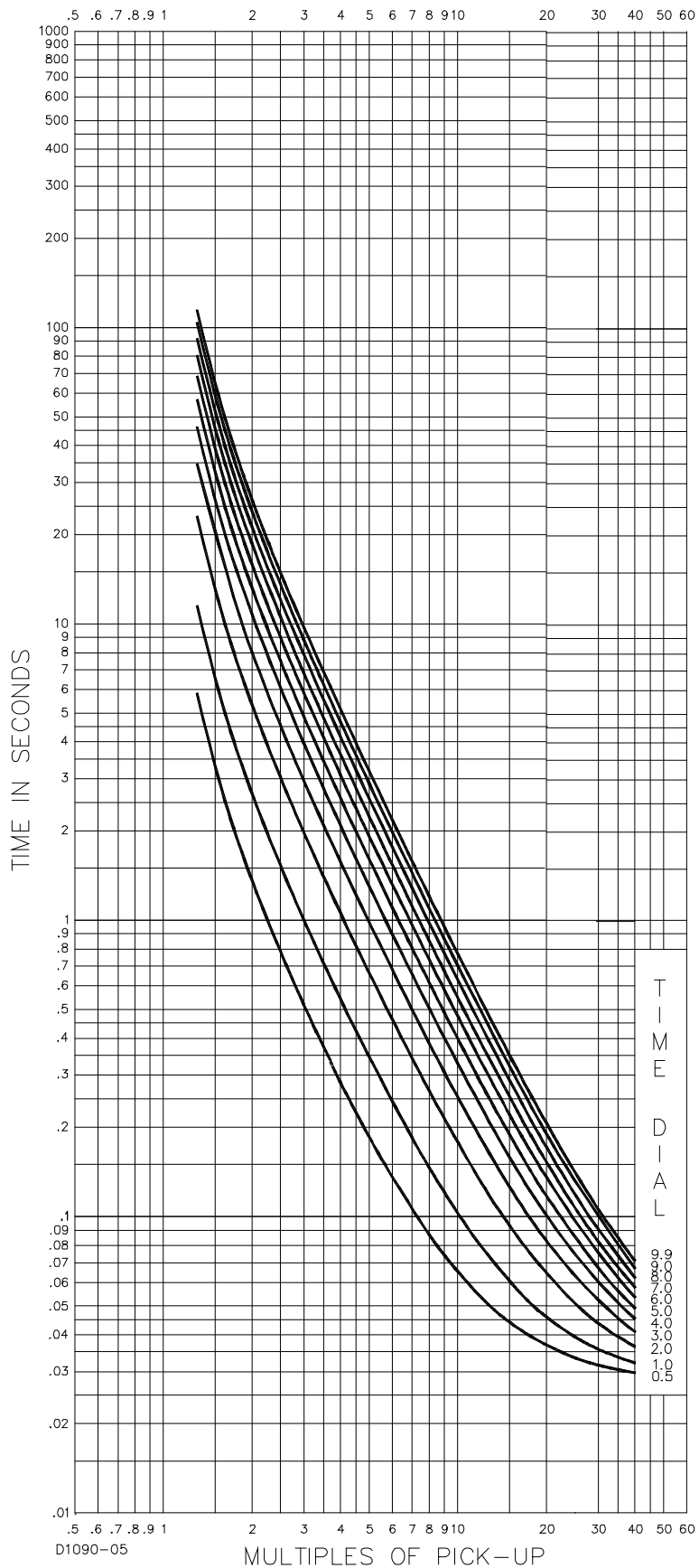

Figure 6-10. BS142 Extremely Inverse (BS142-C) Time Characteristic Curve

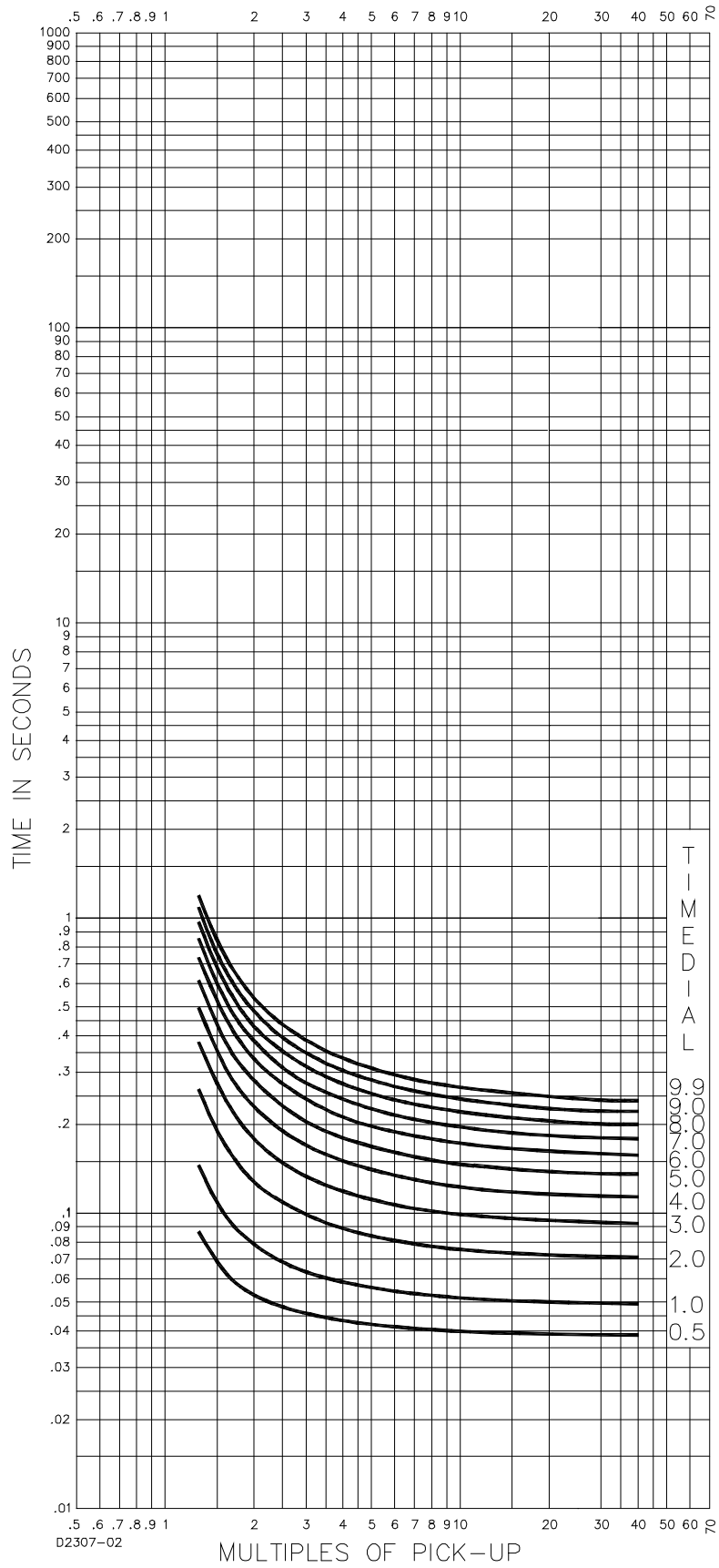

Figure 6-11. Short Inverse (S2) Time Characteristic Curve (SW3-3 On, Similar to IAC 55)

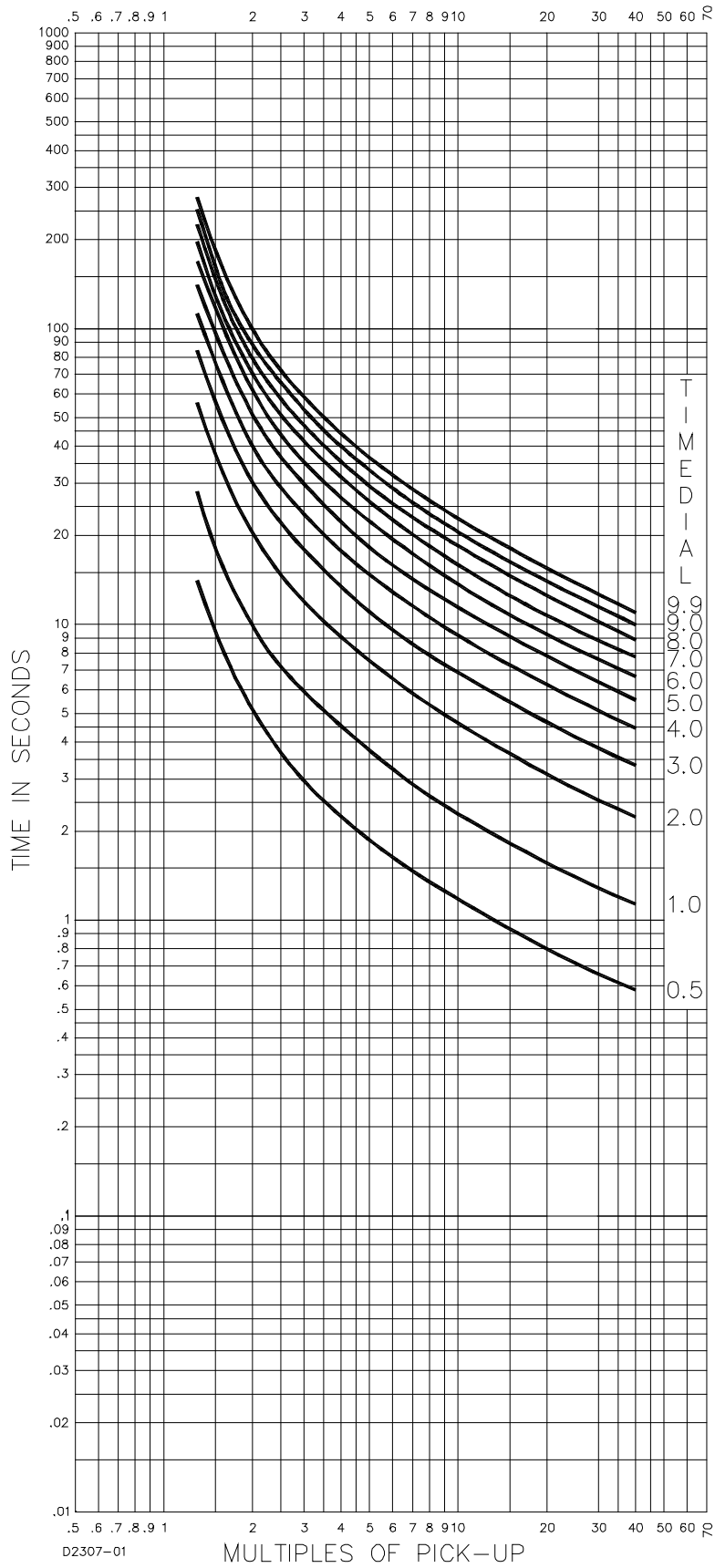

Figure 6-12. Long Inverse (L2) Time Characteristic Curve (SW3-3 On, Similar to IAC 66)

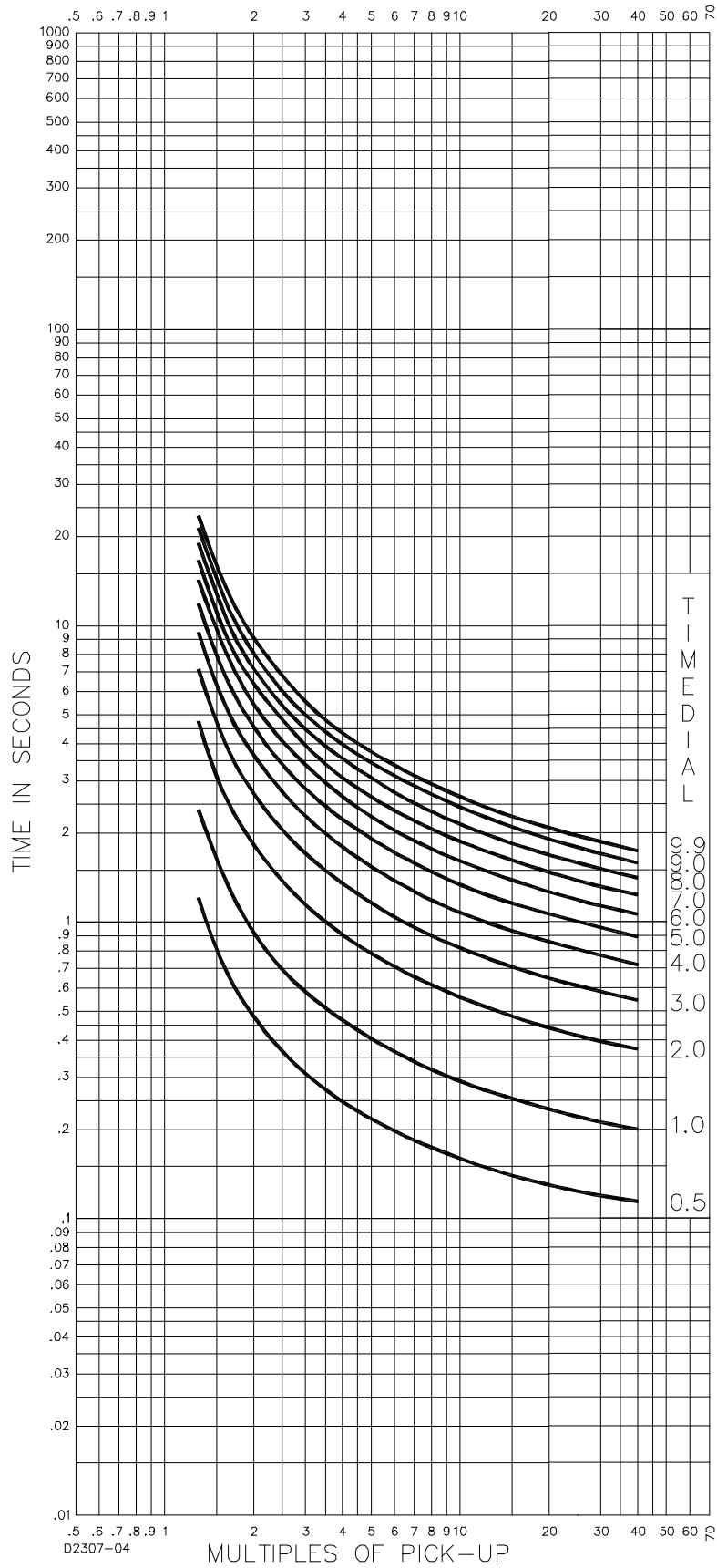

Figure 6-13. Inverse (I2) Time Characteristic Curve (SW3-3 On, Similar to IAC 51)

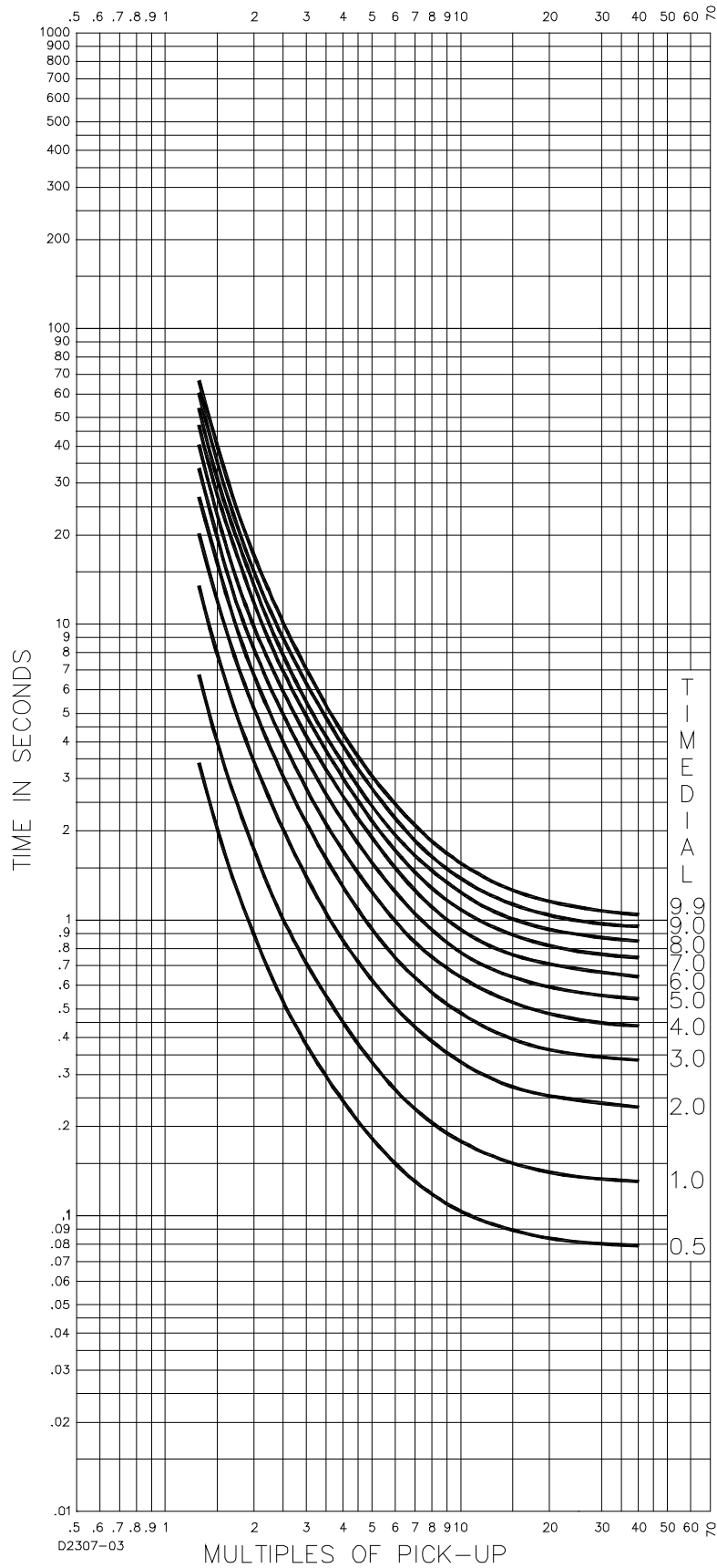

Figure 6-14. Very Inverse (V2) Time Characteristic Curve (SW3-3 On, Similar to IAC 53)

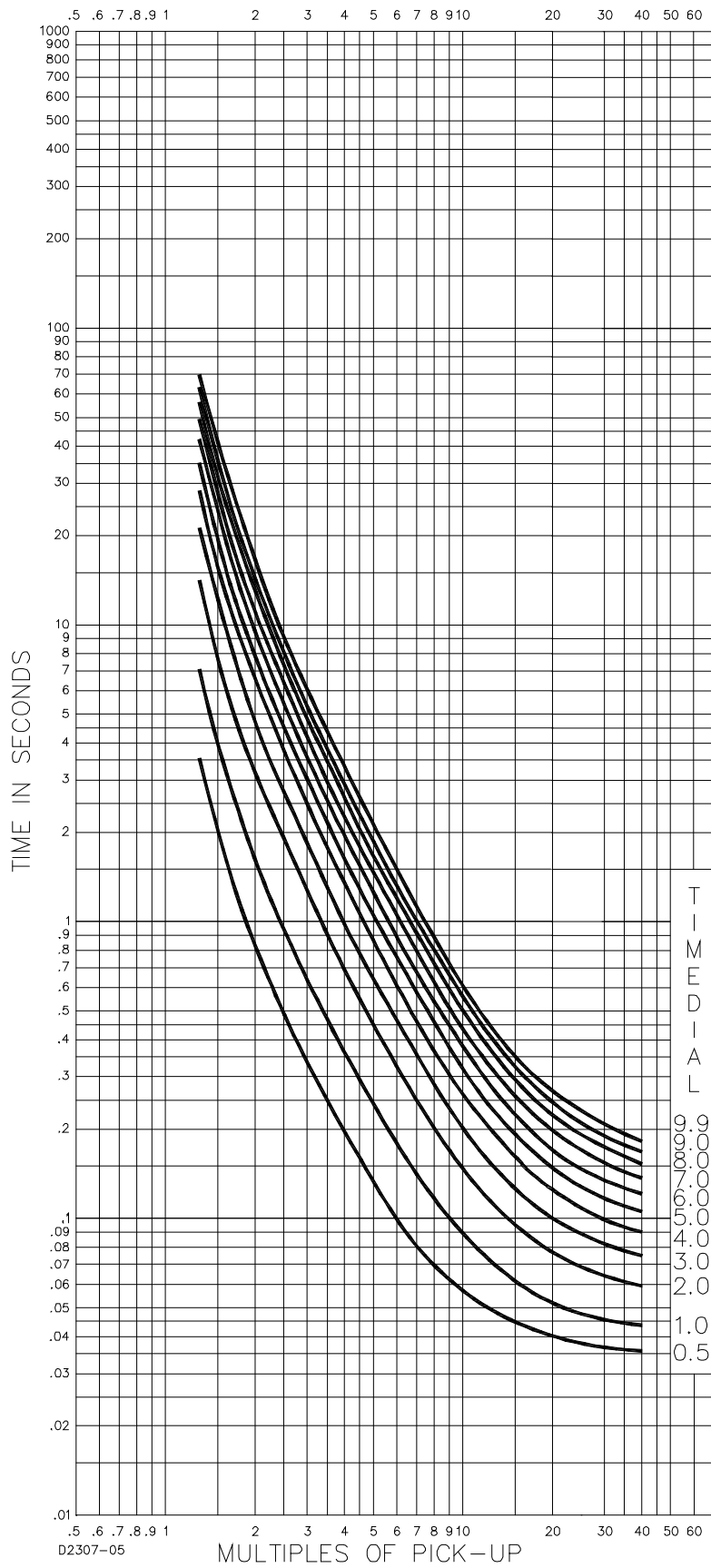

Figure 6-15. Extremely Inverse (E2) Time Characteristic Curve (SW3-3 On, Similar to IAC 77)

Timing Accuracy

Timing accuracy is the sum of ± 1 cycle, $\pm 2\%$. This accuracy applies to the range of 1.3 to 40 times tap and is for a given measured multiple of tap. Measurement accuracy of the multiple of tap is the sum of $\pm 2\%$, ± 25 mA.

Fixed Time Characteristic

The fixed time characteristic corresponds to the time dial setting and provides delays of 0.0 to 9.9 seconds. The time setting is constant over a range of pickup multiples from 1.0 to 40. Accuracy is ± 1 cycle, $\pm 2\%$ of the time to trip for time dial settings of 0.1 and greater.

Integrating Time Reset Characteristic

The relay can be user-configured for integrating or instantaneous type reset.

Integrating reset simulates the disk reset of electromechanical relays and begins when the current decreases below 95% of pickup. BE1-50/51B-241 relays provide the integrating reset function even when input current decreases to zero.

Integrating reset characteristics are defined by the following equation and are illustrated in Figure 6-16. See Table 6-1 and Table 6-2 for the equation constants.

$$T_R = \frac{RD}{M^2 - 1}$$

Where:

- T_R = time to reset in seconds
- R = constant for the particular curve
- D = time dial setting
- M = current in multiples of pickup setting during reset

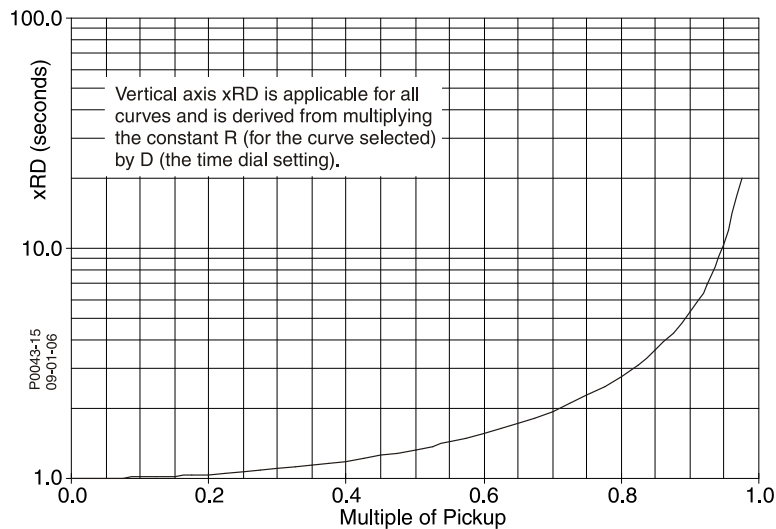

Figure 6-16. Integrating Reset Characteristic Curve

Time characteristic curve equation:

$$T_T = \frac{AD}{M^N - C} + BD + K = \text{Time to Trip}$$

Where:

- D = time dial setting
- M = multiple of pickup setting

Reset characteristic curve equation:

$$T_R = \frac{RD}{M^2 - 1} = \text{Time to Reset}$$

Instantaneous Reset

Reset occurs within 16 milliseconds of when the current decreases to 95% of the pickup level.





Highland, Illinois USA
Tel: +1 618.654.2341
Fax: +1 618.654.2351
email: info@basler.com

Suzhou, P.R. China
Tel: +86 512.8227.2888
Fax: +86 512.8227.2887
email: chinainfo@basler.com